

Sky Air

Product catalogue 2017
for professionals



SkyAir A-series

R-32
IS AN INDUSTRY
REVOLUTION.
BE PART OF IT.

Get ahead of the competition

SkyAir A-series

BLUEVOLUTION



The future is in
your hands
Define the future of A/C

Introducing the new Sky Air A-series with ultra-efficient Bluevolution R32 technology, available in three models: the world-class Alpha, Advance and Active.

The new Sky Air A-series delivers future-proofed, best-in-class climate control for your business and customers.

Design flexibility. More compact. Quieter. With an extended operating range in all climate conditions.

Help is at hand. Quicker and easier installation and usability, even for replacement systems.

Daikin at the heart of the system. Reduced running costs and drastically lowered environmental impact. All thanks to Daikin's tried, tested and trusted technology.

Geared for comfort. Advanced remote control possibilities, geared to your customers' individual needs.

Get ahead of the competition. Talk to Daikin about Sky Air today.
www.daikin.eu/skyairbluevolution



SkyAir Alpha-series

SkyAir Advance-series

SkyAir Active-series

BLUEVOLUTION

Table of contents

Discover the Sky Air A-series	4
7 reasons why Sky Air is unique in the market	6
A solution for every application	12
Indoor units	15
Outdoor units	89
Biddle air curtains	110
Ventilation	113
Control Systems	127
Options & accessories	155
Tools and platforms	163
Technical Drawings	171

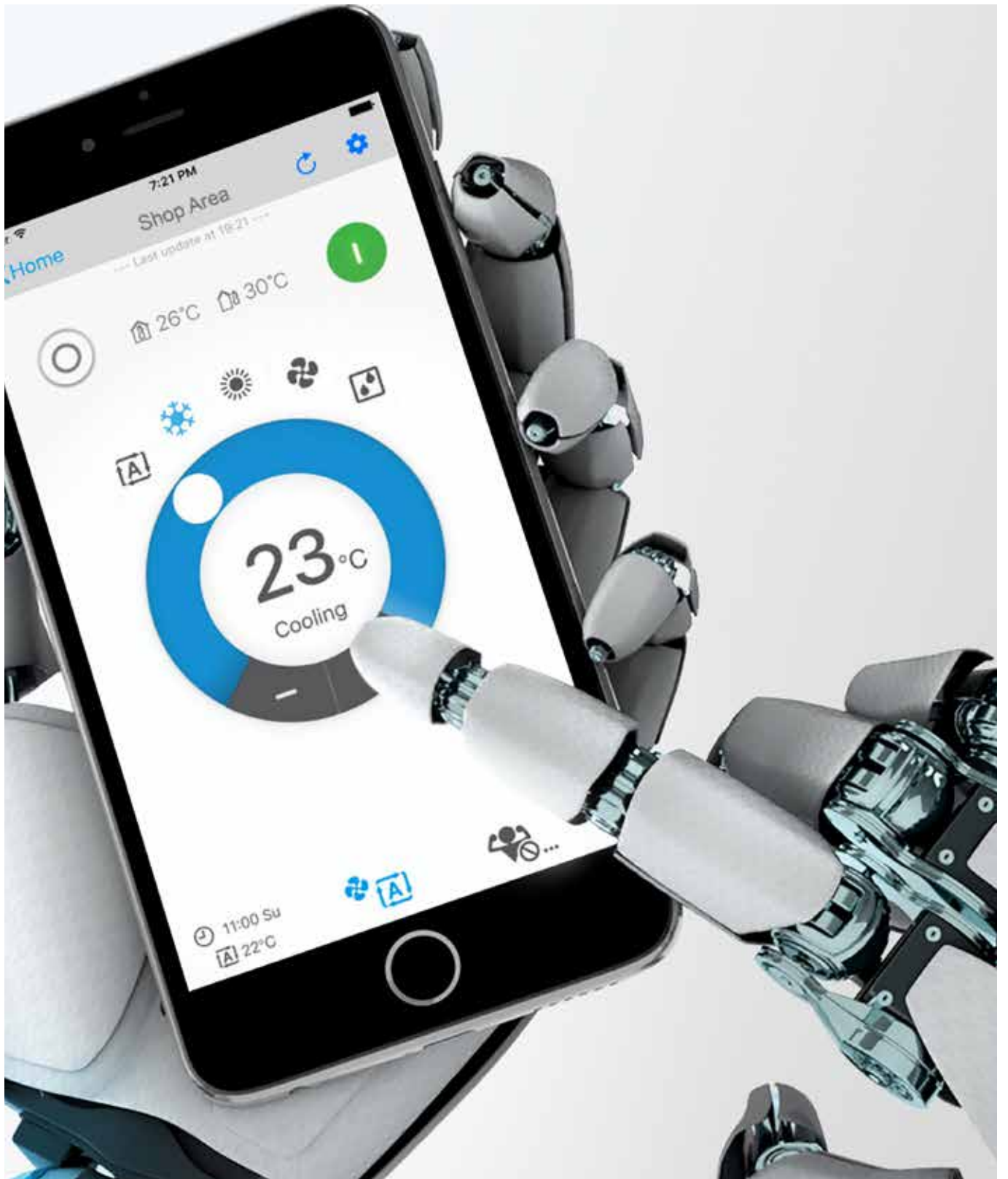

Discover
Sky Air A-series
on page 92

Get ahead of the competition

✓ Europe's first light commercial system using R-32 refrigerant

- › R-32 Global Warming Potential (GWP) is 68% lower than the industry standard R-410A
- › Highest efficiency (**SEER up to 8.02**) in the market
- › Does not require yearly refrigerant containment checks, which reduces maintenance costs
- › 16% less refrigerant charge

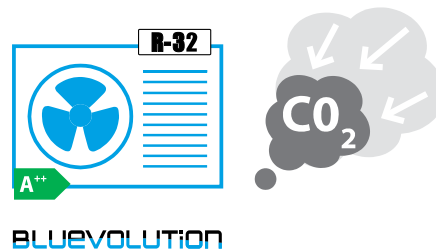

✓ App Control

- › Control your device at anytime from anywhere
- › Intuitive
- › Via smartphone, tablet or cloud



✓ Lighter and more compact units for easy installation. Unique single fan range up to 14 kW

3-row heat exchanger
› Unique 3-row heat exchanger to allow compact casing up to 14 kW



✓ Redesigned pivoting front plate for easy access to vital system components



✓ New 7-segment display to do outdoor unit settings and view operating conditions





Sky Air, the solution for the light commercial sector.

7 reasons why Sky Air is unique in the market

1 Full Sky Air R-32 range delivering future-proofed, best-in-class climate control

SkyAir A-series BLUEEVOLUTION



More details on page 92

System	Type	Model	Product name	PG	71	100	125	140	
Air cooled	Heat pump	SkyAir Alpha-series - Industry leading technology for commercial applications - Dedicated solution for infrastructure cooling - Variable Refrigerant Temperature - Maximum piping length up to 85m - Replacement technology - Extended operation range down to -20°C in both heating and cooling - Pair, twin, triple and double twin application	R-32 A++	RZAG-MV1	102				
				RZAG-MY1	102				
		SkyAir Advance-series - Technology and comfort combined for commercial applications - Very compact and easy to install outdoor units - Maximum piping length up to 50m - Replacement technology - Operation range down to -15°C both cooling and in heating - Pair, twin, triple and double twin application	R-32 A+	RZASG-MV1	103				
				RZASG-MY1	103				
		SkyAir Active-series - Ideal solution for busy environments and small shops - Very compact and easy to install outdoor units - Maximum piping length up to 30m - Replacement technology - Easy-to-mount outdoor units: roof, terrace or wall - Exclusively offered for pair applications	R-32 A	AZAS-MV1	104				
				AZAS-MY1	104				

Full indoor line up available for R-32 and R-410A (over 45 different models)

2 High energy efficiency

- › **Top seasonal efficiency**
 - › SEER up to 8.02 and A++ label in cooling and heating
 - › Variable Refrigerant Temperature that automatically adapts the refrigerant temperature to the load
- NEW** › Round flow and concealed ceiling units with **auto cleaning filter**

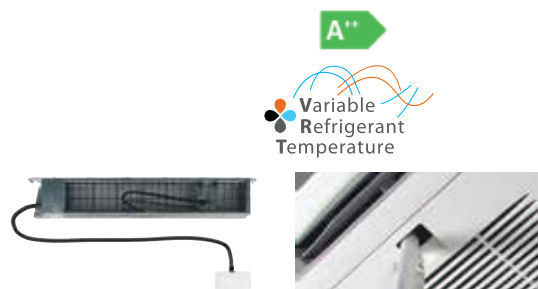

3 Best comfort

- › **Variable Refrigerant Temperature** preventing cold draughts
- › **Low sound** indoor and outdoor units
- › **Presence and floor sensors** direct the air flow away from persons, while ensuring an even temperature distribution
- NEW** › Operation down to **-20°C in heating and cooling** operation
- › Fresh air intake integrated in indoor unit

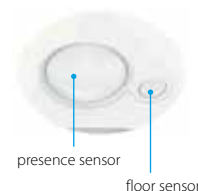

4 Top reliability

- › For **infrastructure cooling**
 - › unique boosted capacity indoor unit systems
 - › duty rotation control
- NEW** › **Refrigerant cooled PCB**
 - › New refrigerant passes keeping heat exchanger and drain holes completely open at all times
 - › **Most extensive testing** before new units leave the factory
 - › **Widest support network** and after sales service
 - › All spare parts available in Europe



bottom plate refrigerant pass

5 Market leading controls

- NEW** › **Remote connectivity**
 - › **Intuitive app** control
 - › **Daikin Cloud Service** offering online control, energy monitoring and comparison of multiple sites
- NEW** › **User-friendly wired remote controller with premium design BRC1H51**
 - › Intuitive touch button control
 - › 3 color versions
 - › Advanced settings can be easily done via your smartphone
- › Dedicated control solutions
 - › for retail applications
 - › for infrastructure cooling



BRC1H51W

6 Superior aesthetics

- › **Fully flat cassette** design unit that integrates fully flat into the ceiling
- › **Auto cleaning** units ensure dirt-free ceilings with high efficiency filters for regular and dust prone areas



7 Unique installation benefits

- › **4-way blow ceiling suspended cassette (FUA)** for rooms without false ceiling.
- › Plug & play Daikin air handling unit with ERQ condensing units
- › Total solution for cooling, heating, air curtains and ventilation
- › Dedicated asymmetric combinations for infrastructure cooling
- NEW** › Reliably replace Daikin and non-Daikin systems without the need for pipe cleaning thanks to the new hepta filtration
- › Use up to 4 indoor units linked to one outdoor unit for long or irregularly shaped rooms



Always in control, no matter where you are

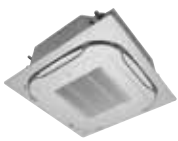

BRP069A81

Online Controller

- > Simple control from your smartphone
- > Control your device at anytime from anywhere
- > For single shop control
- > 3rd party products and services integration via IFTTT

More details
on page 130

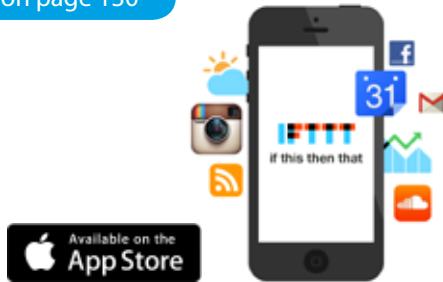

All unified indoor units connectable

Connectable units overview:

Ceiling mounted

- > FCAHG-G
- > FCAG-A
- > FFA-A

Wall mounted

- > FAA-A

Ceiling suspended

- > FHA-A
- > FUA-A

Concealed ceiling

- > FDXM-F3
- > FBA-A
- > FDA-A
- > ADEQ-C

Floor standing

- > FVA-A
- > FNA-A

If this, then that

- > IFTTT is a solution that connects compatible 3rd party products and services (smart meters, lights, thermostats, ...), so they work best for you.

Intelligent Tablet Controller

Intelligent Controller

- > User-friendly touch screen to centrally control your A/C and alarms
- > Connects to the Daikin Cloud Service
- > Built for multi-site control and monitoring
- > Installers and technical managers can see alarms so they can provide remote assistance

More details
on page 140



DCC601A51

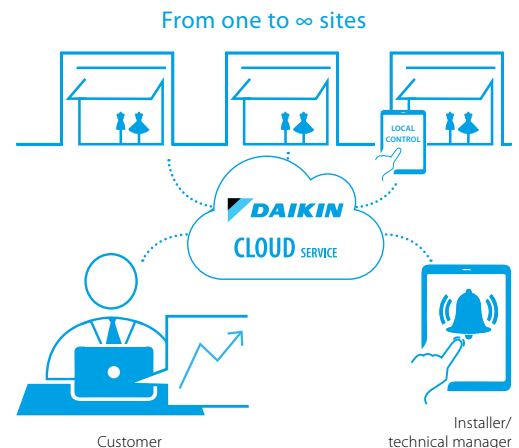

Unique auto cleaning technology



Reduce running costs

- › Automatic filter cleaning ensures high efficiencies and low maintenance costs because the filter is always clean

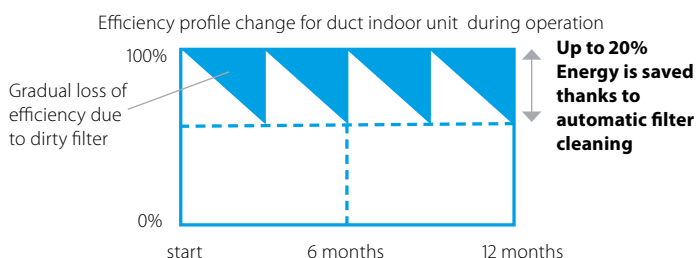

Minimal time required for filter cleaning

- › The dust box can be emptied with a vacuum cleaner for fast and easy cleaning
- › No more dirty ceilings

Unique technology

- › Unique and innovative filter technology inspired by the Daikin auto cleaning cassette



Improved indoor air quality

- › Optimum airflow eliminates draft and insulates sound

How does it work?

- 1 Scheduled automatic filter cleaning
- 2 Dust collects in a dust box that's integrated into the unit
- 3 The dust can easily be removed with a vacuum cleaner

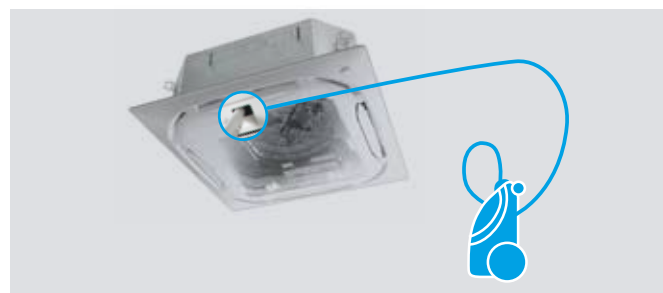
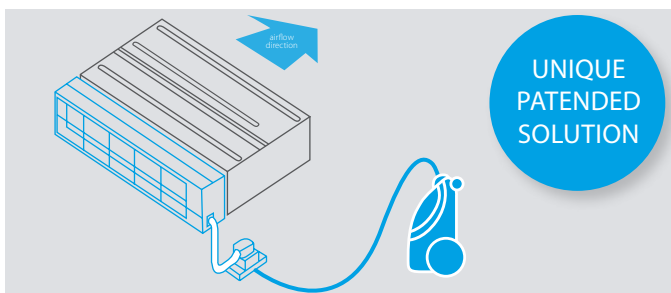

Concealed ceiling units

- › Ideal for hotels and residential applications
- › Cleaning team /owner can clean the filter

More details on page 34

Round flow cassette

- › Ideal for retail
- › Staff/owner can clean the filter
- › No need to use a ladder to reach the unit

More details on page 22

Combination table

	Split / Sky Air				VRV							
	FDXM-F3				FXDQ-A3							
	25	35	50	60	15	20	25	32	40	50	63	
BAE20A62	•	•			•	•	•	•				
BAE20A82									•	•		
BAE20A102			•	•							•	

	Sky Air		VRV
	FCAG-A	FCAHG-G	FXFQ-A
BYCQ140DG9	•	•	•
BYCQ140DGF9 (fine mesh)	•	•	•

Multi zoning kit for concealed ceiling units

The multi-zoning system is a room-by-room controller. It is fitted with motorised dampers, which immediately adapt using Daikin ducted solutions. This system supports control of up to 8 zones via a centralised thermostat located in the main room and individual thermostats for each of the zones.

Benefits

Increased comfort

- › Increases comfort levels by allowing more individual zone control
 - Up to 8 individual zones can be served thanks to separate modulating dampers
 - Individual thermostat for room-by-room or zone-by-zone control

Easy to install

- › Automatic air flow adjustment according to the demand
- › Easy to install, integrates with the Daikin indoor units and system controls
- › Time saving as plenum comes fully pre-assembled with dampers, and control boards
- › Reduces the amount of refrigerant required in the installation

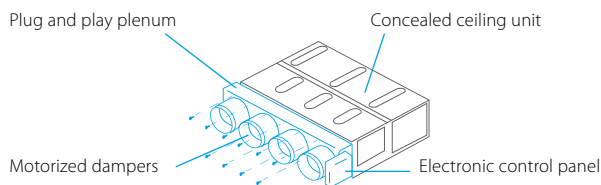

How does it work?

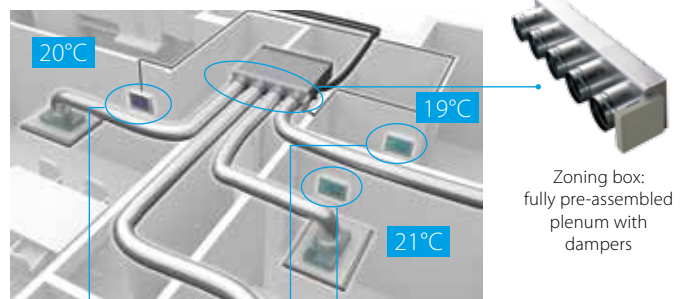

Individual zone thermostats

Blueface - Airzone Main Thermostat

- › Color graphic interface for controlling zones
- › Wired communication



AZCE6BLUEFACECB

Airzone Zone Thermostat

- › Graphic interface with low-energy e-ink screen for controlling zones
- › Radio communication



AZCE6THINKRB

Airzone Zone Thermostat

- › Thermostat with buttons for controlling the temperature
- › Radio communication



AZCE6LITERB

Compatibility

			SkyAir												VRV																				
			FDXM-F3				FBA-A				ADEQ-C				FXDQ-A3						FXSQ-A														
Number of motorised dampers	Reference	Dimensions H x L x D (mm)	25	35	50	60	35	50	60	71	100	125	140	71	100	125	15	20	25	32	40	50	63	15	20	25	32	40	50	63	71	80	100	125	140
Standard Ceiling Void	2	AZEZ6DAIST07XS2																																	
		AZEZ6DAIST07S2																																	
	3	AZEZ6DAIST07XS3																																	
		AZEZ6DAIST07S3																																	
	4	AZEZ6DAIST07S4																																	
		AZEZ6DAIST07M4																																	
		AZEZ6DAIST07M5																																	
		AZEZ6DAIST07L5																																	
		AZEZ6DAIST07M6																																	
		AZEZ6DAIST07L6																																	
Compact Ceiling Void	2	AZEZ6DAISL01S2																																	
	3	AZEZ6DAISL01S3																																	
	4	AZEZ6DAISL01M4																																	
	5	AZEZ6DAISL01L5																																	
		AZEZ6DAISL01L5																																	



Infrastructure cooling

- › For rooms and enclosures that require round-the-clock cooling
- › Where continuous uptime is the absolute requirement for server data protection

Between
20-40%
sensible capacity
increase

Reliable

- Guaranteed system operation:
- › Oversized indoor units boost cooling capacity and prevent freeze-ups on the indoor side
 - › Wide operating range envelope: operation range in cooling down to -20°C and up to +52°C

Efficient

- Optimum return on investment:
- › Lowers running costs by using highly efficient direct expansion cooling systems
 - › Lower running costs compared to other DX systems and water based chillers.
 - › Minimises environmental impact with A++ energy labels
 - › Reduces mechanical cooling and energy consumption with the free cooling option for single phase systems

Flexible

- › Scalable in capacity
- › Improved infrastructure control and management
- › Lower physical footprint since no floor space is occupied
- › Wide range of indoor units to suit application preferences (ceiling suspended cassettes, wall mounted indoors, concealed ceiling ducted type indoors)

Duty rotation application example

SYSTEM 1 FBA140 IN OPERATION
SYSTEM 2 FBA140 STANDBY

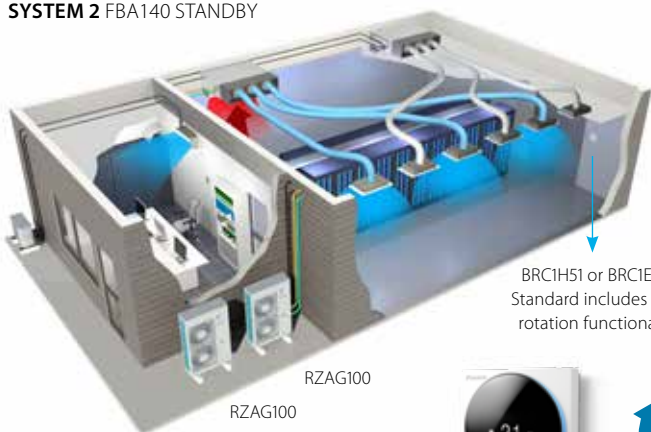

SYSTEM 1 FBA140 STANDBY
SYSTEM 2 FBA140 IN OPERATION

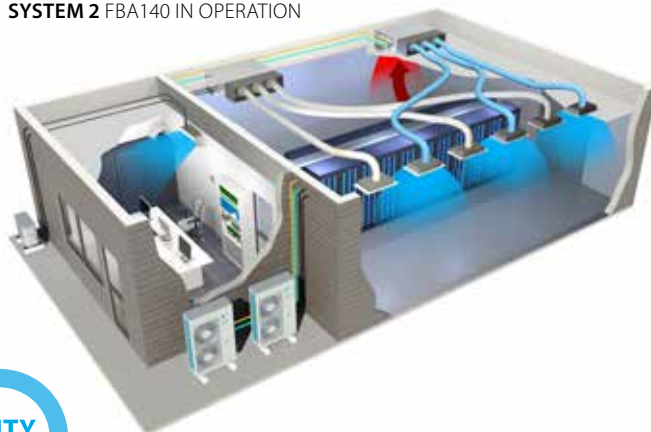

BRC1H51 or BRC1E53*
Standard includes duty rotation functionality





"We were very happy to work with Daikin in installing one of the latest fully controllable systems with operational flexibility, which met all our requirements."

Retail shop representative

Shops

Reducing retail costs

- › Open door trading thanks to Biddle air curtains
- › Discreet with limited visual and operating impact
- › Reduces energy usage and costs
- › Worry-free installation
- › User-friendly control

In the current commercial environment, retailers are under pressure to **reduce both store development and running costs**. Legislation adds further financial pressure with different energy-efficient schemes. Therefore affordable, energy-efficient solutions

are vital to minimise lifetime costs, while ensuring compliance with the latest regulations.

Whatever the site and requirements we can design a system that is **economical**, has low environmental impact and uses the very latest technology. Our heat pumps extract heat from the outside air even in cold weather to warm the retail space and can be installed either on roof tops or against walls - the ultimate in **installation flexibility**. And our air curtains solve that problem of comfort loss resulting from exterior doors.

Check on
YouTube

www.youtube.com/DaikinEurope

Store & shop



"Leading edge design in harmony with the construction and interior design."

Architect

Offices

Efficiency in the workplace

- › Fully flat cassette: Design and genius in one.
- › Cutting the cost of hot water.
- › Fresh air: A healthier office atmosphere.
- › Centralised control: Complete Daikin package for office building management

Efficient building and facilities management is key to minimising operational costs. Daikin's customised office solutions give you **full control** over energy

consumption – creating the ideal working conditions and minimising environmental impact.

Daikin's office air conditioning can be integrated into a whole **climate control solution**. **Heat recovery** between components, free cooling ventilation and free hot water production all result in lower running costs and **minimum carbon emissions**.



"Total renovation and expansion of the restaurant meant new air conditioning equipment was required. Daikin was the first and only supplier to contact as we had already had good experience in the past!"

Owner of a highly-rated restaurant

Restaurants

Perfect ambiance for dining

- › Ensures an even temperature distribution to create the perfect dining environment.
- › Heat recovery ventilation keeps the air clean
- › Highly energy efficient
- › Uses intelligent control systems operated from one central location.

Nothing should distract diners from enjoying the **perfect ambiance**, and that ambiance includes the **optimum temperature and**

ventilation. That is exactly what Daikin's concealed ceiling units deliver through whisper quiet operation and improved comfort from the 3-step air flow control.

These turn your customer's restaurant into a comfortable, welcoming environment. And with **centralised control** and easy scheduling for the entire restaurant system, **energy use is minimised** to reduce your customer's running costs.



"A reliable system and guaranteed continuous operation are what count for me."

General office manager



IT rooms, laboratories and telecom shelters

Sky Air for infrastructure cooling

- › Continuous cooling operation.
- › Dedicated infrastructure cooling settings
- › Unique selection method with capacity tables down to -20°C outdoor temperature
- › Enhanced **reliability** thanks to **assymetric combinations** (e.g. 125 class indoor + 100 class outdoor)

Servers, especially racks of servers, generate a great deal of heat and this needs to be removed through **continuous cooling**. This is achieved through **duty**

rotation between units after a certain period of use to ensure that at any time, one unit is working while the other is available for maintenance.

Given the critical importance of continuous cooling for server rooms, the system can be managed via an RTD-10 controller that can monitor and control up to 8 indoor units either directly or via the building management system (RTD-NET).

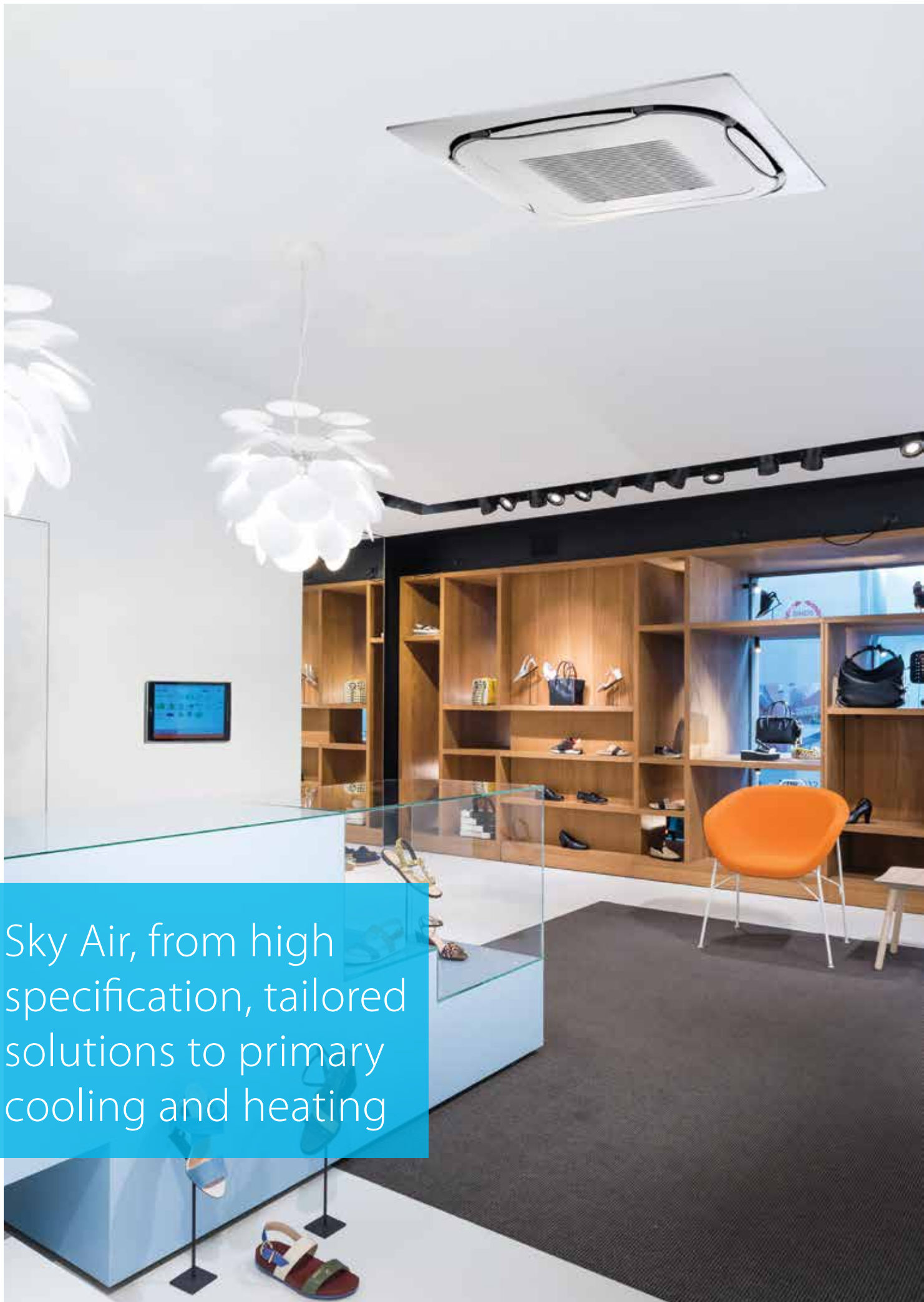

Sky Air, from high specification, tailored solutions to primary cooling and heating

Indoor units



A wide range of unified indoor units for the use with R-32 and R-410A refrigerant.

Products overview	16
Benefits overview	18

Ceiling mounted cassettes 22

FCAHG-G	R-32 / R-410A	25
FCAG-A	R-32 / R-410A	26
FFA-A	R-32 / R-410A	33

Concealed ceiling units 34

FDXM-F3	R-32 / R-410A	36
FBA-A	R-32 / R-410A	37
FDA-A	R-32 / R-410A	41
FDQ-B	R-410A	71
ADEQ-C	R-410A	72
ABQ-C	R-410A	73

Wall mounted units 42

FAA-A	R-32 / R-410A	42
-------	-----------------------------	----

Ceiling suspended units 46

FHA-A	R-32 / R-410A	46
FUA-A	R-32 / R-410A	50
AHQ-C	R-410A	80



















Floor standing units 52

FVA-A	R-32 / R-410A	52
-------	-----------------------------	----

Concealed floor standing units 55

FNA-A	R-32 / R-410A	55
-------	-----------------------------	----

Product overview

Type	Model	Product name		PG			
Ceiling mounted cassette	UNIQUE High COP, Round flow cassette	FCAHG-G		25	<p>360° air discharge for the highest efficiency and comfort</p> <ul style="list-style-type: none"> - High COP cassette ensures top performance for commercial applications - Auto cleaning function ensures high efficiency - Intelligent sensors save energy and maximize comfort - Flexibility to suit every room layout 		
	UNIQUE Round flow cassette	FCAG-A		26-29	<p>360° air discharge for the highest efficiency and comfort</p> <ul style="list-style-type: none"> - Auto cleaning function ensures high efficiency - Intelligent sensors save energy and maximize comfort - Flexibility to suit every room layout - Lowest installation height in the market - 27~29 dB(A) on low fan speed 		
	UNIQUE Fully flat cassette	FFA-A	 	33	<p>Unique design in the market that integrates fully flat into the ceiling</p> <ul style="list-style-type: none"> - Perfect integration in standard architectural ceiling tiles - Blend of iconic design and engineering excellence with a white or silver and white finish - Intelligent sensors save energy and maximize comfort - Flexibility to suit every room layout without changing the location of the unit! - Quietest 600 x 600 cassette on the market 		
Concealed ceiling	Slim concealed ceiling unit	NEW Auto cleaning option	NEW Multi zoning option	FDXM-F3		36	<p>Slim design for flexible installation</p> <ul style="list-style-type: none"> - Compact dimensions enable installation in narrow ceiling voids - Medium external static pressure up to 40Pa - Small capacity unit developed for small of well insulated rooms - Auto cleaning function ensures high efficiency and reliability
	Concealed ceiling unit with medium ESP	NEW Multi zoning option		FBA-A		37-40	<p>Slimmest yet most powerful medium static pressure unit on the market!</p> <ul style="list-style-type: none"> - Slimmest unit in class, only 245mm - Low operating sound level - Medium external static pressure up to 150Pa facilitates using flexible ducts of varying lengths - Automatic air flow adjustment function measures the air volume and static pressure and adjusts it towards the nominal air flow, guaranteeing comfort
	Concealed ceiling unit with high ESP			FDA-A		41	<p>ESP up to 200Pa, ideal for large sized buildings</p> <ul style="list-style-type: none"> - Discretely concealed in the ceiling: only the grilles are visible - Possibility to change ESP via wired remote control allows optimisation of the supply air volume - Flexible installation as the air suction direction can be altered from rear to bottom suction
	Concealed ceiling unit with high ESP			FDQ-B		71	<p>ESP up to 250Pa, ideal for extra large sized spaces</p> <ul style="list-style-type: none"> - Blends unobtrusively with any interior décor: only the suction and discharge grilles are visible - Up to 26.4kW in heating mode
	Concealed ceiling unit			ADEQ-C		72	<p>Ideal for residential applications with false ceilings</p> <ul style="list-style-type: none"> - Energy label up to A - Medium external static pressure up to 150Pa facilitates using flexible ducts of varying lengths - Slimmest unit in class, only 245mm - Exclusively offered for pair applications
	Concealed ceiling unit			ABQ-C		73	<p>Ideal for medium sized shops with false ceilings</p> <ul style="list-style-type: none"> - Discretely concealed in the ceiling: only the grilles are visible - Best protection against possible water leakage
	Wall mounted	Wall mounted unit		FAA-A		42-44	<p>For rooms with no false ceilings nor free floor space</p> <ul style="list-style-type: none"> - The air is comfortably spread up- and downwards thanks to 5 different discharge angles - Easy maintenance as this can be done from the front of the unit - Easy to install: 100 class is 35% lighter than previous model - Flexible to install: pipe connection can be bottom, left or right
Ceiling suspended	Ceiling suspended unit		FHA-A		46-48	<p>For wide rooms with no false ceilings nor free floor space</p> <ul style="list-style-type: none"> - Ideal for comfortable air flow in wide rooms thanks to Coanda effect - Even rooms with ceilings up to 3.8m can be heated up or cooled down very easily! - Can be mounted in corners or narrow spaces without any problem 	
	UNIQUE 4-way blow ceiling suspended unit		FUA-A		50-51	<p>Unique Daikin unit for high rooms with no false ceilings nor free floor space</p> <ul style="list-style-type: none"> - Even rooms with ceilings up to 3.5m can be heated up or cooled down very easily! - Flexibility to suit every room layout without changing the location of the unit! - Optimum comfort guaranteed with automatic air flow adjustment to the required load - The air is comfortably spread up- and downwards thanks to 5 different discharge angles 	
	Ceiling suspended unit		AHQ-C		80	<p>For wide rooms with no false ceilings nor free floor space</p> <ul style="list-style-type: none"> - Guarantees a stable temperature 	
Floor standing	Floor standing unit		FVA-A		52-53	<p>For spaces with high ceilings</p> <ul style="list-style-type: none"> - Ideal solution for commercial spaces with no or narrow false ceilings - Even rooms with very high ceilings can be heated up or cooled down very easily! - Guarantees a stable temperature - Vertical and horizontal outblow 	
	Concealed floor standing unit		FNA-A		55	<p>Designed to be concealed in walls, only grilles remain visible</p> <ul style="list-style-type: none"> - Slimmest unit on the market with a depth of only 200mm! - Both window sill or ducted installation are possible thanks to sufficient ESP - Whisper quiet operation allows installation in any location 	

Full R-32 BLUEEVOLUTION line up

Indoor units

Capacity class										Outdoor unit combination						
										R-32			R-410A			
25	35	50	60	71	100	125	140	200	250	SkyAir Alpha-series RZAG*	SkyAir Advance-series RZASG*	SkyAir Active-series AZAS*	Seasonal Smart RZQG*	Seasonal Classic RZQSG*	AZQS*	Super Inverter RZQ*
				•	•	•	•			✓			✓	✓		
	•	•	•	•	•	•	•			✓	✓	✓	✓	✓	✓	✓
•	•	•	•							✓	✓		✓	✓		✓
•	•	•	•							✓	✓		✓	✓		✓
	•	•	•	•	•	•	•			✓	✓	✓	✓	✓		✓
						•				✓	✓		✓	✓		✓
								•	•							✓
				•	•	•									✓	
					•	•	•								✓	
	•	•	•	•	•	•	•			✓	✓	✓	✓	✓		✓
				•	•	•				✓	✓		✓	✓		✓
				•	•	•	•			✓	✓		✓	✓		✓
				•	•	•	•			✓	✓		✓	✓	✓	
•	•	•	•							✓	✓		✓	✓		✓

Indoor units

Benefits overview **SkyAir**

We care	 Seasonal efficiency - Smart use of energy	Seasonal efficiency gives a more realistic indication on how efficient air conditioners operate over an entire heating or cooling season.
	 Inverter technology	In combination with inverter controlled outdoor units
	 Home leave operation	During absence, the indoor temperature can be maintained at a certain level.
	 Fan only	The air conditioner can be used as fan, blowing air without cooling or heating.
	 Auto cleaning filter	The filter automatically cleans itself. Simplicity of upkeep means optimum energy efficiency and maximum comfort without the need for expensive or time-consuming maintenance.
	 Floor and presence sensor	The presence sensor directs the air away from any person detected in the room, when the air flow control is on. The floor sensor detects the average floor temperature and ensures an even temperature distribution between ceiling and floor.
Comfort	 Draught prevention	When starting to warm up or when the thermostat is off, the air discharge direction is set horizontally and the fan to low speed, to prevent draught. After warming up, air discharge and fan speed are set as desired.
	 Whisper quiet	Daikin indoor units are whisper quiet. Also the outdoor units are guaranteed not to disturb the quiet of the neighbourhood.
	 Auto cooling-heating changeover	Automatically selects cooling or heating mode to achieve the set temperature.
Air treatment	 Air filter	Removes airborne dust particles to ensure a steady supply of clean air.
Humidity control	 Dry programme	Allows humidity levels to be reduced without variations in room temperature.
Air flow	 Ceiling soiling prevention	A special function prevents air blowing out too long in horizontal position, to prevent ceiling stains.
	 Vertical auto swing	Possibility to select automatic vertical moving of the air discharge louvre, for uniform air flow and temperature distribution.
	 Fan speed steps	Allows to select up to the given number of fan speed.
	 Individual flap control	Individual flap control via the wired remote controller makes it simple to fix the position of each flap individually, to suit any new room configuration. Optional closure kits are available as well.
Remote control & timer	 Online controller	Can control and monitor the status of a heating system or up to 50 split air conditioning units
	 Weekly timer	Timer can be set to start operation anytime on a daily or weekly basis
	 Infrared remote control	Infrared remote control with LCD to start, stop and regulate the air conditioner from a distance.
	 Wired remote control	Wired remote control to start, stop and regulate the air conditioner from a distance.
	 Centralised control	Centralised control to start, stop and regulate several air conditioners from one central point.
	 Multi zoning NEW	Allows up to 6 individual climate zones with one indoor unit
Other functions	 Infrastructure cooling	Remove in a reliable, efficient and flexible way the heat constantly generated by the IT and server equipment to ensure maximum uptime while offering the best return on investment.
	 Auto-restart	The unit restarts automatically at the original settings after power failure.
	 Self-diagnosis	Simplifies maintenance by indicating system faults or operating anomalies.
	 Drain pump kit	Facilitates condensation draining from the indoor unit.
	 Twin/triple/double twin application	2, 3 or 4 indoor units can be connected to only 1 outdoor unit. All indoor units operate within the same mode (cooling or heating) from one remote control.
	 Multi model application	Up to 5 indoor units (even different capacities) can be connected to a single outdoor unit. All indoor units can individually be operated within the same mode.
	 VRV for residential application	Up to 9 indoor units (even different capacities and up to 71 class) can be connected to a single outdoor unit. All indoor units can individually be operated within the same mode.

Ceiling mounted cassette units			Concealed ceiling units						Ceiling suspended units	4-Way blow ceiling suspended unit	Ceiling suspended units	Wall mounted unit	Floor standing units	
FCAHG-G	FCAG-A	FFA-A	FDXM-F3	FBA-A	FDA-A	FDQ-B	ADEQ-C	ABQ-C	FHA-A	FUA-A	AHQ-C	FAA-A	FVA-A	FNA-A
•	•	•	•	•	•		•		•	•		•	•	•
•	•	•	•	•	•	•	•	•	•	•	•	•	•	•
•	•	•	•	•	•	•	•	•	•	•	•	•	•	•
•	•		• NEW											
•	•	•												
•	•	•								•				
•	•	•		•			•							
•	•	•	•	•	•	•	•	•	•	•	•	•	•	•
•	•	•												
•	•	•	•	•	•		•		•	•		•	•	•
•	•	•												
•	•	•	•	•	•		•		•	•		•	•	•
5	5	3	3	3	3	2	3	3	3	3	3	3	3	3
•	•	•								•				
• NEW	• NEW	• NEW	• NEW	• NEW	• NEW		• NEW		• NEW	• NEW		• NEW	• NEW	• NEW
•	•	•	• depending on controller	•	•	•	•	•	•	•	•	•	•	•
optional	optional	optional	optional	optional	optional		optional		optional	optional	standard	optional		optional
optional	optional	optional	optional	optional	optional	optional	optional	standard	optional	optional	optional	optional	optional	optional
optional	optional	optional	optional	optional	optional	optional	optional		optional	optional		optional	optional	optional
			• NEW	• NEW										
•	•	•	•	•	•		•	•	•	•	•	•	•	•
•	•	•	•	•	•	•	•	•	•	•	•	•	•	•
•	•	•	•	•	•		•		•	•		•	•	•
standard	standard	standard		standard	standard	•	optional		optional	standard		optional		
•	•	•	•	•	•		•		•	•		•		•
	•	•	•	•			•		•					•
	•	•	•	•					•					•

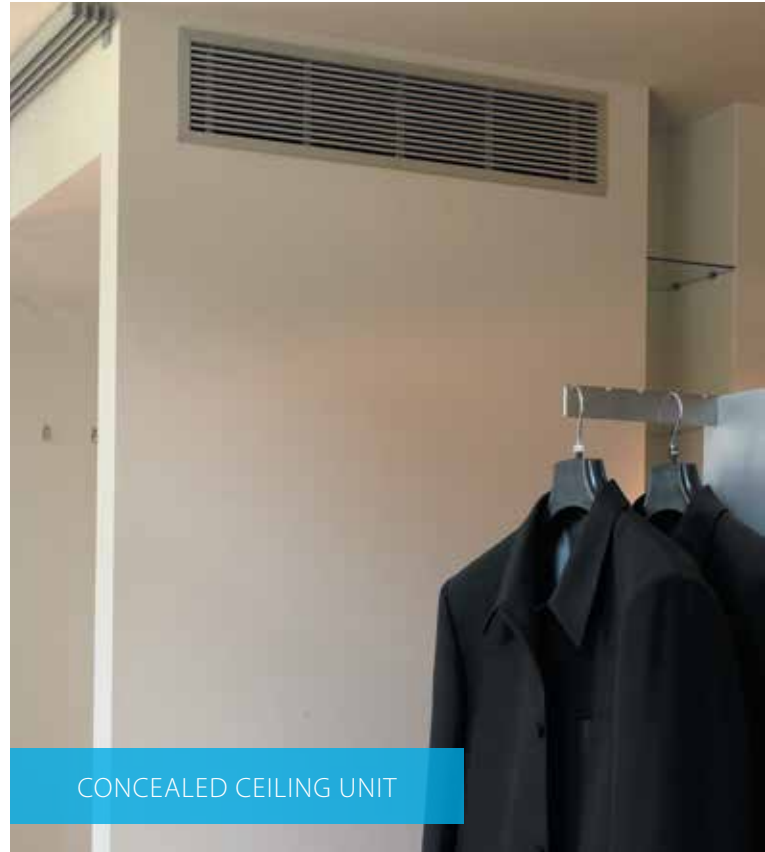



WALL MOUNTED UNIT



CEILING SUSPENDED UNIT



AUTO CLEANING CASSETTE WITH FINE MESH FILTER, IDEAL FOR CLOTHING SHOPS



FCAHG-G/FCAG-A Auto cleaning cassette

Why choose a round flow cassette?

- 360° air discharge for optimum comfort
- Intelligent sensors for maximum efficiency



More energy efficient and user-friendly than any other cassette

- › Running costs are reduced by 50% compared with standard solutions
- › Automatic filter cleaning.
- › Less time is required to maintain the filter: dust can be removed easily with a vacuum cleaner without opening the unit.

Finer mesh panel

- › For dust prone areas (i.e. clothing and book shops) a finer mesh panel (BYCQ140DGF9) ensures consistent performance and optimum air distribution
- › Clean ceilings ensured thanks to fine mesh and clean filter

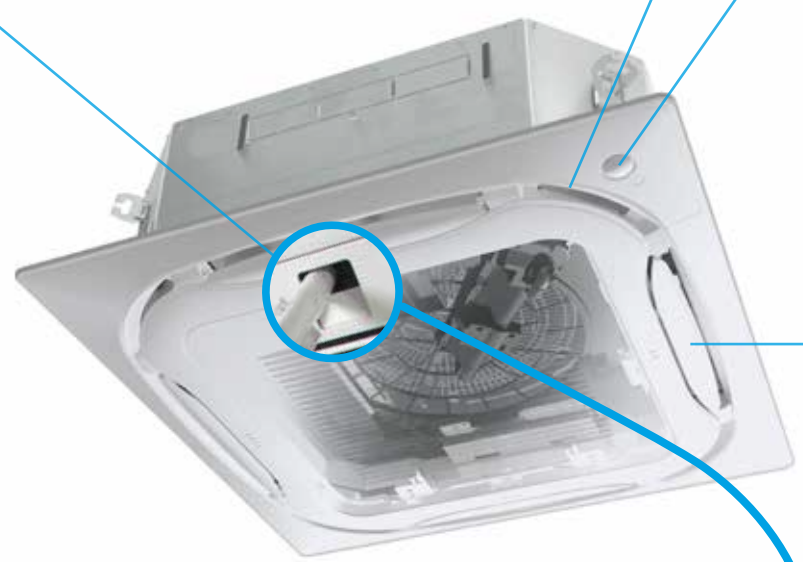

BYCQ140DG9	BYCQ140DGF9
Auto-cleaning panel	Auto-cleaning panel with fine mesh filter
White with grey louvers	White with grey louvers

Auto-cleaning cassette for maintaining the optimum store atmosphere



Air distribution with a clean filter



Air distribution with a dusty filter

Dust can be removed easily with a vacuum cleaner without opening the unit.

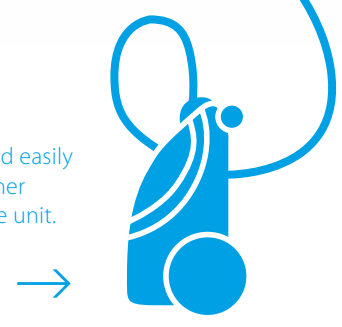

References

Coral shop, UK

Running costs were reduced by up to 50% compared with standard solutions thanks to clean filter

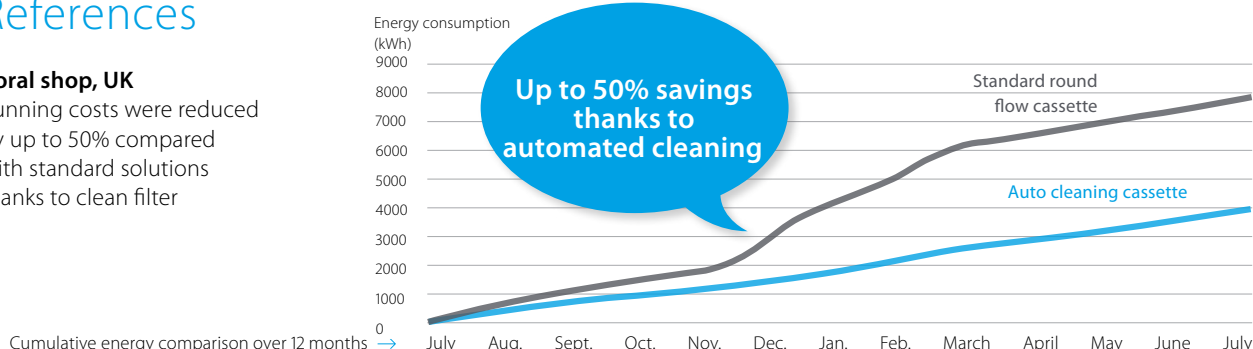

360° air discharge for improved comfort

> Industry-first and proven design.

Intelligent sensors improve efficiency and comfort even more

> The presence sensor adjusts the set point if no one is detected in the room leading to up to 27% savings. It also automatically directs air flow away from any person to avoid draught.

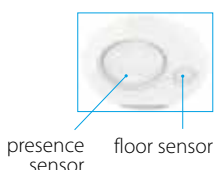

> The infrared floor sensor detects the average floor temperature and ensures even temperature distribution between ceiling and floor to prevent cold feet.

Flexible installation

> Flaps can be individually controlled or closed using the wired remote control, to suit room configuration. Optional closure kits are also available.

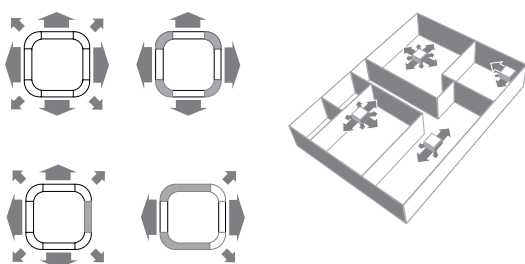

Benefits for the installer

- > Product with unique functions in this market.
- > Less time needed for onsite maintenance.
- > Use the controller to individually open or close any of the four flaps to easily adapt to a changing room layout.
- > Easy set-up of the sensor option to improve comfort and save energy.

Benefits for the consultant

- > Product with unique functions in this market.
- > Designed for use in all types and sizes of commercial offices and retail environments.
- > Ideal product for improving BREEAM score/EPBD in combination with Sky Air or VRV IV heat pump units.

Benefits for the end user

- > Designed for use in all types and sizes of commercial offices and retail environments.
- > Perfect environment conditions: no more draughts or cold feet.
- > Save up to 50% on running costs with the auto-cleaning panel, which also facilitates maintenance.
- > Your customers can save up to 27% on their energy bills thanks to the sensor option.
- > Flexible use of space thanks to individual flap control.

Marketing tools

- > Visit the website: https://www.daikin.eu/en_us/product-group/round-flow-cassette.html



www.youtube.com/DaikinEurope



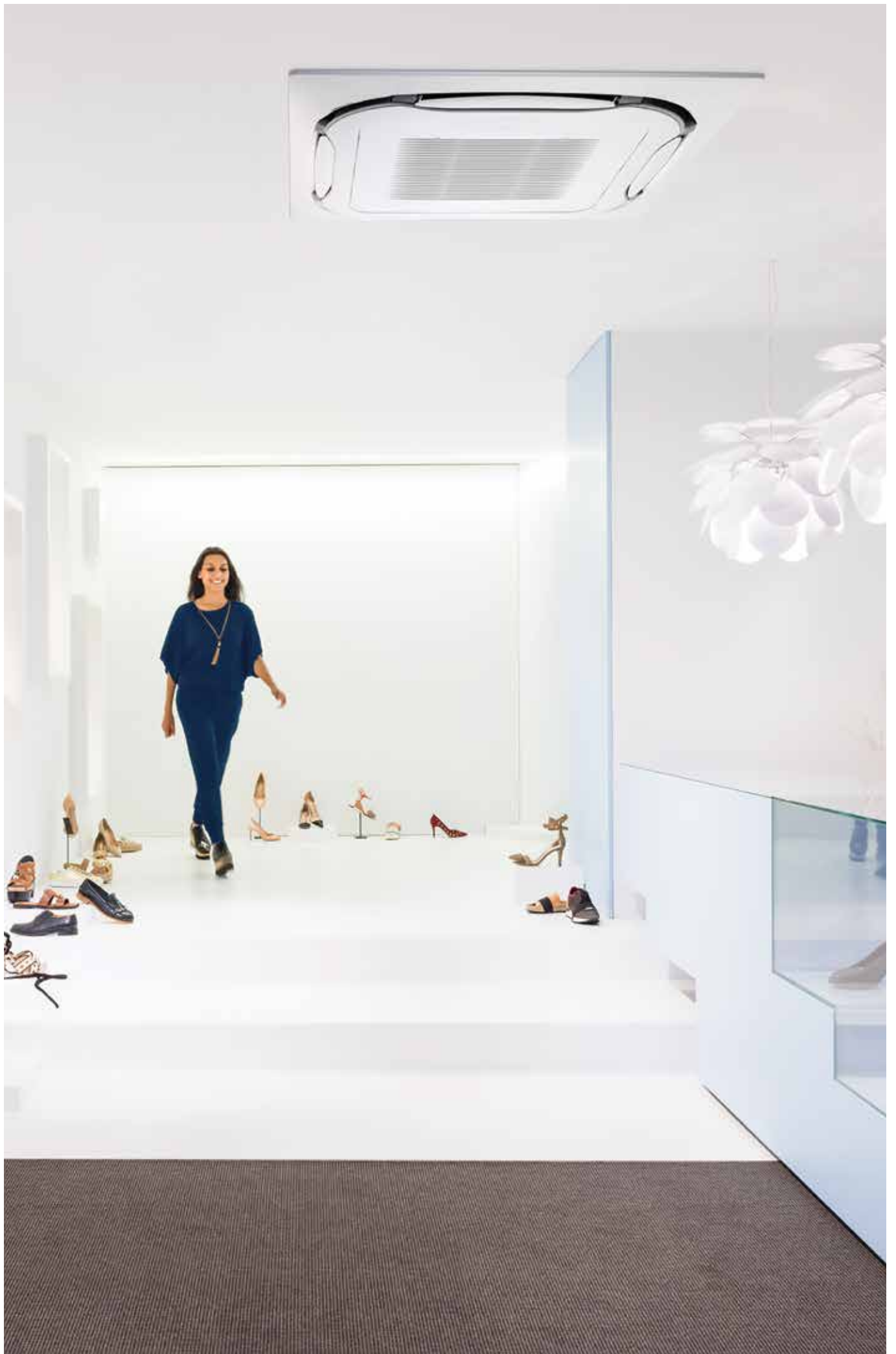



High COP, round flow cassette

360° air discharge for optimum efficiency and comfort

- High COP cassette ensures top performance, great savings in energy consumption and a comfortable environment for commercial applications
- Unified indoor unit range for R-32 and R-410A
- Combining with R-32 Bluevolution technology, reduces environmental impact with 68% compared to R-410A, leads directly to lower energy consumption thanks to its high energy efficiency and has up to lower 16% refrigerant charge
- Automatic filter cleaning results in higher efficiency & comfort and lower maintenance costs. 2 filters available: standard filter and finer mesh filter (for fine dust applications e.g. clothing shops)
- Two optional intelligent sensors improve energy efficiency and comfort.
- Individual flap control: flexibility to suit every room layout without changing the location of the unit!
- Modern style decoration panel is available in 3 different variations: white (RAL9010) with grey louvers, full white (RAL9010) or auto cleaning panel
- 5 different fan speeds available for maximum comfort
- Reduced energy consumption thanks to specially developed small tube heat exchanger, DC fan motor and drain pump
- Optional fresh air intake
- Branch duct discharge allows to optimize air distribution in irregular shaped rooms or to supply air to small adjacent rooms



Standard drain pump with 675mm lift increases flexibility and installation speed

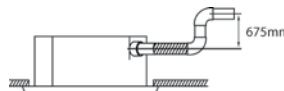

Efficiency data		FCAHG + RZAG		71G+71MV1	100G+100MV1	125G+125MV1	140G+140MV1	71G+71MY1	100G+100MY1	125G+125MY1	140G+140MY1
Cooling capacity	Nom.	kW		6.80	9.50	12.1	13.4	6.80	9.50	12.1	13.4
Heating capacity	Nom.	kW		7.50	10.8	13.5	15.5	7.50	10.8	13.5	15.5
Seasonal efficiency (according to EN14825)	Cooling	Energy efficiency class		A++				A++			
		Pdesign	kW	6.80	9.50	12.1	13.4	6.80	9.50	12.1	13.4
	SEER		7.72	7.35	8.02	7.93	7.72	7.35	8.02	7.93	
	Annual energy consumption	kWh	308	452	905	1,014	308	452	905	1,014	
	Heating (Average climate)	Energy efficiency class		A++				A++			
Pdesign		kW	4.70		9.52		4.70		9.52		
SCOP/A			4.61	4.81	4.53	4.44	4.61	4.81	4.53	4.44	
Annual energy consumption	kWh	1,427	2,771	2,942	3,002	1,427	2,771	2,942	3,002		

Indoor unit			FCAHG		71G	100G	125G	140G	71G	100G	125G	140G
Dimensions	Unit	HeightxWidthxDpeth	mm									
Weight	Unit		kg									
Air filter	Type		Resin net									
Decoration panel	Model		BYCQ140DGF9 - auto cleaning panel with fine mesh filter / BYCQ140DG9 - auto cleaning panel / BYCQ140DW - full white / BYCQ140D - white with grey louvers									
	Colour		Pure White (RAL 9010)									
	Dimensions	HeightxWidthxDpeth	mm									
Weight	Unit		kg									
Fan	Air flow rate	Cooling	Low/Medium/High	m³/min	12.2/16.7/21.2	19.0/25.7/32.3	19.9/26.7/33.5	21.1/27.3/33.5	12.2/16.7/21.2	19.0/25.7/32.3	19.9/26.7/33.5	21.1/27.3/33.5
		Heating	Low/Medium/High	m³/min	12.2/16.7/21.2	19.0/25.7/32.3	19.9/26.7/33.5	21.1/27.3/33.5	12.2/16.7/21.2	19.0/25.7/32.3	19.9/26.7/33.5	21.1/27.3/33.5
Sound power level	Cooling		dB(A)	53		61		53		61		
	Heating		dB(A)	53		61		53		61		
Sound pressure level	Cooling	Low/High	dB(A)	29/36	33/44	35/45	37/45	29/36	33/44	35/45	37/45	
	Heating	Low/High	dB(A)	29/36	33/44	35/45	37/45	29/36	33/44	35/45	37/45	
Control systems	Infrared remote control		BRC7FA532F									
	Wired remote control		BRC1H51 / BRC1E53A / BRC1E53B / BRC1E53C / BRC1D52									
Power supply	Phase/Frequency/Voltage		Hz/V									

Outdoor unit			RZAG		71MV1	100MV1	125MV1	140MV1	71MY1	100MY1	125MY1	140MY1	
Dimensions	Unit	HeightxWidthxDpeth	mm										
Weight	Unit		kg										
Sound power level	Cooling		dB(A)	64	66	69	70	65	66	69	70		
	Heating		dB(A)	49	51	52		49	51	52			
Operation range	Cooling	Ambient	Min.~Max.	°CDB									
	Heating	Ambient	Min.~Max.	°CWB									
Refrigerant	Type/GWP		R-32/675										
	Charge	kg/TCO2Eq	2.95/1.99		3.75/2.53		2.95/1.99		3.75/2.53				
Piping connections	Liquid/Gas		mm										
	Piping length	OU - IU	Max.	m		55		85		m		55	
	System	Equivalent	Chargeless	m		75		100		m		75	
	Additional refrigerant charge	kg/m	See installation manual										
	Level difference	IU - OU	Max.	m									
Power supply	Phase/Frequency/Voltage		Hz/V										
Current - 50Hz	Maximum fuse amps (MFA)	A	20		32		16						

(1) BYCQ140D7W1: pure white standard panel with grey louvers; BYCQ140D7W1W: pure white standard panel with white louvers; BYCQ140D7GW1: pure white auto cleaning panel.
 (2) EER/COP according to Eurovent 2012, for use outside EU only
 (3) The BYCQ140D7W1W has white insulations. Be informed that formation of dirt on white insulation is visibly stronger and that it is consequently not advised to install the BYCQ140D7W1W decoration panel in environments exposed to concentrations of dirt.
 (4) MFA is used to select the circuit breaker and the ground fault circuit interrupter (earth leakage circuit breaker). For more detailed information on each combination, please refer to the electrical data drawing.



Round flow cassette

360° air discharge for optimum efficiency and comfort

- > Combination with Sky Air Alpha-series ensures best in class quality, highest efficiency and performance
- > Unified indoor unit range for R-32 and R-410A
- > Combining with R-32 Bluevolution technology, reduces environmental impact with 68% compared to R-410A, leads directly to lower energy consumption thanks to its high energy efficiency and has up to lower 16% refrigerant charge
- > Automatic filter cleaning results in higher efficiency & comfort and lower maintenance costs. 2 filters available: standard filter and finer mesh filter (for fine dust applications e.g. clothing shops)
- > Two optional intelligent sensors improve energy efficiency and comfort.
- > Individual flap control: flexibility to suit every room layout without changing the location of the unit!
- > Modern style decoration panel is available in 3 different variations: white (RAL9010) with grey louvers, full white (RAL9010) or auto cleaning panel
- > 5 different fan speeds available for maximum comfort
- > Reduced energy consumption thanks to specially developed small tube heat exchanger, DC fan motor and drain pump
- > Optional fresh air intake
- > Branch duct discharge allows to optimize air distribution in irregular shaped rooms or to supply air to small adjacent rooms
- > Standard drain pump with 675mm lift increases flexibility and installation speed

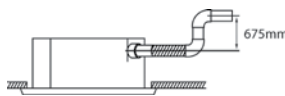

Efficiency data		FCAG + RZAG		71A + 71MY1	100A + 100MY1	125A + 125MY1	140A + 140MY1	71A + 71MY1	100A + 100MY1	125A + 125MY1	140A + 140MY1
Cooling capacity	Nom.	kW		6.80	9.50	12.1	13.4	6.80	9.50	12.1	13.4
Heating capacity	Nom.	kW		7.50	10.8	13.5	15.5	7.50	10.8	13.5	15.5
Seasonal efficiency (according to EN14825)	Cooling	Energy efficiency class		A++		-		A++		-	
		Pdesign	kW	6.80	9.50	12.1	13.4	6.80	9.50	12.1	13.4
		SEER		6.86	7.14	7.80	7.17	6.86	7.14	7.80	7.17
	Heating (Average climate)	Annual energy consumption	kWh	347	466	931	1,121	347	466	931	1,121
		Energy efficiency class		A+	A++	-		A+	A++	-	
		Pdesign	kW	4.70	7.80	9.52		4.70	7.80	9.52	
SCOP/A		4.41	4.61	4.34		4.41	4.61	4.34			
Annual energy consumption	kWh	1,492	2,369	3,071		1,492	2,369	3,071			

Indoor unit		FCAG		71A	100A	125A	140A	71A	100A	125A	140A	
Dimensions	Unit	HeightxWidthxD	mm	204x840x840		246x840x840		204x840x840		246x840x840		
Weight	Unit	kg		21		24		21		24		
Air filter	Type	Resin net										
Decoration panel	Model	BYCQ140DGF9 - auto cleaning panel with fine mesh filter / BYCQ140DG9 - auto cleaning panel / BYCQ140DW - full white / BYCQ140D - white with grey louvers										
	Colour	Pure White (RAL 9010)										
	Dimensions	HeightxWidthxD	mm	130x950x950 / 130x950x950 / 50x950x950 / 50x950x950								
Fan	Air flow rate	Cooling	Low/Medium/High	m³/min	9.3/12.5/15.3	12.4/17.6/22.8	12.4/19.2/26.0	9.3/12.5/15.3	12.4/17.6/22.8	12.4/19.2/26.0	12.4/19.2/26.0	
					Heating	Low/Medium/High	m³/min	9.1/12.1/15.0	12.4/17.6/22.8	12.4/19.2/26.0	9.1/12.1/15.0	12.4/17.6/22.8
Sound power level	Cooling	dBA	51	54	58	51	54	58	51	54	58	
												Heating
Sound pressure level	Cooling	Low/High	dBA	28/35	29/37	29/41	28/35	29/37	29/41	28/33	29/37	29/41
				Heating	Low/High	dBA	28/33	29/37	29/41	28/33	29/37	29/37
Control systems	Infrared remote control		BRC7FA532F									
	Wired remote control		BRC1H51 / BRC1E53A / BRC1E53B / BRC1E53C / BRC1D52									
Power supply	Phase/Frequency/Voltage		Hz/V 1~/50/60/220-240/220									

Outdoor unit		RZAG		71MV1	100MV1	125MV1	140MV1	71MY1	100MY1	125MY1	140MY1	
Dimensions	Unit	HeightxWidthxD	mm	990x940x320		1,430x940x320		990x940x320		1,430x940x320		
Weight	Unit	kg		70		92		78		70		
Sound power level	Cooling	Nom.	dBA	64	66	69	73	65	66	69	70	
				Heating	Nom.	dBA	46	47	50	54	46	47
Sound pressure level	Cooling	Nom.	dBA	49	51	52	57	49	51	52	52	
				Heating	Nom.	dBA						
Operation range	Cooling	Ambient	Min.~Max.	°CDB	-20~-52		-15~-46		-20~-52			
					Heating	Ambient	Min.~Max.	°CWB	-20~-18.0		-15~-15.5	
Refrigerant	Type/GWP		R-32/675									
	Charge	kg/TCO2Eq	2.95/1.99	3.75/2.53		2.90/1.96		2.95/1.99		3.75/2.53		
Piping connections	Liquid/Gas		mm 9.52/15.9									
	Piping length	OU - IU	Max.	m	55	85		50		55		85
		System	Equivalent	m	75	100		70		75		100
	Chargeless		m	40		30		40				
	Additional refrigerant charge		kg/m	See installation manual								
Level difference		IU - OU	Max.	m	30.0							
Power supply	Phase/Frequency/Voltage		Hz/V 1~/50/220-240									
Current - 50Hz	Maximum fuse amps (MFA)		A 20 32 16									

(1) BYCQ140D7W1: pure white standard panel with grey louvers; BYCQ140D7W1W: pure white standard panel with white louvers; BYCQ140D7GW1: pure white auto cleaning panel.
 (2) EER/COP according to Eurovent 2012, for use outside EU only
 (3) The BYCQ140D7W1W has white insulations. Be informed that formation of dirt on white insulation is visibly stronger and that it is consequently not advised to install the BYCQ140D7W1W decoration panel in environments exposed to concentrations of dirt.
 (4) MFA is used to select the circuit breaker and the ground fault circuit interrupter (earth leakage circuit breaker). For more detailed information on each combination, please refer to the electrical data drawing.



Round flow cassette

360° air discharge for optimum efficiency and comfort

- › Combination with Sky Air Advance-series ensures good value for money for all types of commercial applications
- › Unified indoor unit range for R-32 and R-410A
- › Combining with R-32 Bluevolution technology, reduces environmental impact with 68% compared to R-410A, leads directly to lower energy consumption thanks to its high energy efficiency and has up to lower 16% refrigerant charge
- › Automatic filter cleaning results in higher efficiency & comfort and lower maintenance costs. 2 filters available: standard filter and finer mesh filter (for fine dust applications e.g. clothing shops)
- › Two optional intelligent sensors improve energy efficiency and comfort
- › Individual flap control: flexibility to suit every room layout without changing the location of the unit!
- › Modern style decoration panel is available in 3 different variations: white (RAL9010) with grey louvers, full white (RAL9010) or auto cleaning panel



Indoor units

Efficiency data		FCAG + RZASG		71A + 71MV1	100A + 100MV1	125A + 125MV1	140A + 140MV1	100A + 100MY1	125A + 125MY1	140A + 140MY1	
Cooling capacity	Nom.	kW		6.80	9.50	12.1	13.4	9.50	12.1	13.4	
Heating capacity	Nom.	kW		7.50	10.8	13.5	15.5	10.8	13.5	15.5	
Seasonal efficiency (according to EN14825)	Cooling	Energy efficiency class		A++			-			A++	
		Pdesign	kW	6.80	9.50	12.1	13.4	9.50	12.1	13.4	
		SEER		6.47	6.55	5.76	6.53	6.55	5.76	6.53	
			Annual energy consumption	kWh	368	507	1,261	1,231	507	1,261	1,231
	Heating (Average climate)	Energy efficiency class		A		A+		-		A+	
		Pdesign	kW	4.50		6.00		7.80		6.00	7.80
SCOP/A			4.00	4.17	4.05	4.31	4.17	4.05	4.31		
		Annual energy consumption	kWh	1,575	2,016	2,074	2,534	2,016	2,074	2,534	
Indoor unit		FCAG		71A	100A	125A	140A	100A	125A	140A	
Dimensions	Unit	HeightxWidthxDpeth		204x840x840		246x840x840					
Weight	Unit			21		24					
Air filter	Type	Resin net									
Decoration panel	Model	BYCQ140DGF9 - auto cleaning panel with fine mesh filter / BYCQ140DG9 - auto cleaning panel / BYCQ140DW - full white / BYCQ140D - white with grey louvers									
	Colour	Pure White (RAL 9010)									
	Dimensions	HeightxWidthxDpeth		130x950x950 / 130x950x950 / 50x950x950 / 50x950x950							
	Weight			10.3 / 10.3 / 5.4 / 5.4							
Fan	Air flow rate	Cooling	Low/Medium/High	m ³ /min	9.3/12.5/15.3	12.4/17.6/22.8	12.4/19.2/26.0	12.4/17.6/22.8	12.4/19.2/26.0		
		Heating	Low/Medium/High	m ³ /min	9.1/12.1/15.0	12.4/17.6/22.8	12.4/19.2/26.0	12.4/17.6/22.8	12.4/19.2/26.0		
Sound power level	Cooling			dB(A)	51	54	58	54	58		
	Heating			dB(A)	51	54	58	54	58		
Sound pressure level	Cooling	Low/High			dB(A)	28/35	29/37	29/41	29/37	29/41	
	Heating	Low/High			dB(A)	28/33	29/37	29/41	29/37	29/41	
Control systems	Infrared remote control		BRC7FA532F								
	Wired remote control		BRC1H51 / BRC1E53A / BRC1E53B / BRC1E53C / BRC1D52								
Power supply	Phase/Frequency/Voltage		Hz/V 1~/50/60/220-240/220								
Outdoor unit		RZASG		71MV1	100MV1	125MV1	140MV1	100MY1	125MY1	140MY1	
Dimensions	Unit	HeightxWidthxDpeth		770x900x320		990x940x320					
Weight	Unit			60		70	78	70	71	77	
Sound power level	Cooling			65		70	71	70	71	73	
Sound pressure level	Cooling	Nom.			46		53	54	53	54	
	Heating	Nom.			47			57			
Operation range	Cooling	Ambient	Min.~Max.			-15~-46					
	Heating	Ambient	Min.~Max.			-15~-15.5					
Refrigerant	Type/GWP		R-32/675								
	Charge		kg/CO ₂ Eq	2.45/1.65		2.60/1.76		2.90/1.96		2.60/1.76 2.90/1.96	
Piping connections	Liquid/Gas				mm 9.52/15.9						
	Piping length	OU - IU	Max.			m 50					
		System	Equivalent			m 70					
			Chargeless			m 30					
	Additional refrigerant charge				kg/m See installation manual						
Level difference		IU - OU	Max.			m 30.0					
Power supply	Phase/Frequency/Voltage		Hz/V 1~/50/220-240 3~/50/380-415								
Current - 50Hz	Maximum fuse amps (MFA)		A 20		25		32		16		

(1) BYCQ140D7W1: pure white standard panel with grey louvers; BYCQ140D7W1W: pure white standard panel with white louvers; BYCQ140D7GW1: pure white auto cleaning panel.
 (2) EER/COP according to Eurovent 2012, for use outside EU only
 (3) The BYCQ140D7W1W has white insulations. Be informed that formation of dirt on white insulation is visibly stronger and that it is consequently not advised to install the BYCQ140D7W1W decoration panel in environments exposed to concentrations of dirt.
 (4) MFA is used to select the circuit breaker and the ground fault circuit interrupter (earth leakage circuit breaker). For more detailed information on each combination, please refer to the electrical data drawing.



Round flow cassette

360° air discharge for optimum efficiency and comfort

- › Ideal solution for small businesses and shops
- › Unified indoor unit range for R-32 and R-410A
- › Combining with R-32 Bluevolution technology, reduces environmental impact with 68% compared to R-410A, leads directly to lower energy consumption thanks to its high energy efficiency and has up to lower 16% refrigerant charge
- › Automatic filter cleaning results in higher efficiency & comfort and lower maintenance costs. 2 filters available: standard filter and finer mesh filter (for fine dust applications e.g. clothing shops)
- › Two optional intelligent sensors improve energy efficiency and comfort
- › Individual flap control: flexibility to suit every room layout without changing the location of the unit!
- › Modern style decoration panel is available in 3 different variations: white (RAL9010) with grey louvers, full white (RAL9010) or auto cleaning panel



Efficiency data		FCAG + AZAS	71A + 71MV1	100A + 100MV1	125A + 125MV1	140A + 140MV1	100A + 100MY1	125A + 125MY1	140A + 140MY1	
Cooling capacity	Nom.	kW	6.80	9.50	12.1	13.4	9.50	12.1	13.4	
Heating capacity	Nom.	kW	7.50	10.8	13.5	15.5	10.8	13.5	15.5	
Seasonal efficiency (according to EN14825)	Cooling	Energy efficiency class	A+			-			A+	
		Pdesign	kW	6.80	9.50	12.1	13.0	9.50	12.1	13.0
		SEER		5.87	5.67	5.40	6.00	5.67	5.40	6.00
		Annual energy consumption	kWh	405	586	1,345	1,300	586	1,345	1,300
		Heating (Average climate)	Energy efficiency class	A			-			A
	Pdesign	kW	4.50	6.00	7.80	6.00	7.80	6.00	7.80	
	SCOP/A		4.00	3.85	3.80	4.31	3.85	3.80	4.31	
	Annual energy consumption	kWh	1,575	2,182	2,211	2,534	2,182	2,211	2,534	

Indoor unit		FCAG	71A	100A	125A	140A	100A	125A	140A
Dimensions	Unit	HeightxWidthxDepth	204x840x840		246x840x840				
Weight	Unit		21		24				
Air filter	Type		Resin net						
Decoration panel	Model		BYCQ140DGF9 - auto cleaning panel with fine mesh filter / BYCQ140DG9 - auto cleaning panel / BYCQ140DW - full white / BYCQ140D - white with grey louvers						
	Colour		Pure White (RAL 9010)						
	Dimensions	HeightxWidthxDepth	130x950x950 / 130x950x950 / 50x950x950 / 50x950x950						
	Weight		10.3/5.4/10.3/5.4						
Fan	Air flow rate	Cooling	Low/Medium/High	m ³ /min	9.3/12.5/15.3	12.4/17.6/22.8	12.4/19.2/26.0	12.4/17.6/22.8	12.4/19.2 (0.000)/26.0
		Heating	Low/Medium/High	m ³ /min	9.1/12.1/15.0	12.4/17.6/22.8	12.4/19.2/26.0	12.4/17.6/22.8	12.4/19.2 (0.000)/26.0
Sound power level	Cooling		dBA	51	54	58	54	58	
	Heating		dBA	51	54	58	54	58	
Sound pressure level	Cooling	Low/High	dBA	28/35	29/37	29/41	29/37	29/41	
	Heating	Low/High	dBA	28/33	29/37	29/41	29/37	29/41	
Control systems	Infrared remote control		BRC7FA532F						
	Wired remote control		BRC1H51 / BRC1E53A / BRC1E53B / BRC1E53C / BRC1D52						
Power supply	Phase/Frequency/Voltage	Hz/V	1~/50/60/220-240/220						

Outdoor unit		AZAS	71MV1	100MV1	125MV1	140MV1	100MY1	125MY1	140MY1	
Dimensions	Unit	HeightxWidthxDepth	770x900x320		990x940x320					
Weight	Unit		60	70	78	70	77			
Sound power level	Cooling		dBA	65	70	71	73	70	71	
	Heating		dBA	46	53	54	53	54		
Sound pressure level	Cooling	Nom.	dBA	46	53	54	53	54		
	Heating	Nom.	dBA	47		57				
Operation range	Cooling	Ambient	Min.~Max.	°CDB						
	Heating	Ambient	Min.~Max.	°CWB						
Refrigerant	Type/GWP		R-32/675							
	Charge	kg/CO ₂ Eq	2.45/1.65	2.60/1.76	2.90/1.96	2.60/1.76	2.90/1.96			
Piping connections	Liquid/Gas		mm							
	Piping length	OU - IU	Max.	m						
		System	Equivalent	m						
			Chargeless	m						
			Additional refrigerant charge	kg/m						
	Level difference	IU - OU	Max.	m						
Power supply	Phase/Frequency/Voltage	Hz/V	1~/50/220-240				3~/50/380-415			
Current - 50Hz	Maximum fuse amps (MFA)	A	20	25	32		16			

(1) BYCQ140D7W1: pure white standard panel with grey louvers; BYCQ140D7W1W: pure white standard panel with white louvers; BYCQ140D7GW1: pure white auto cleaning panel.
 (2) EER/COP according to Eurovent 2012, for use outside EU only
 (3) The BYCQ140D7W1W has white insulations. Be informed that formation of dirt on white insulation is visibly stronger and that it is consequently not advised to install the BYCQ140D7W1W decoration panel in environments exposed to concentrations of dirt.
 (4) MFA is used to select the circuit breaker and the ground fault circuit interrupter (earth leakage circuit breaker). For more detailed information on each combination, please refer to the electrical data drawing.

Round flow cassette

360° air discharge for optimum efficiency and comfort

- › Combination with split outdoor units is ideal for small retail, offices or residential applications
- › Unified indoor unit range for R-32 and R-410A
- › Combining with R-32 Bluevolution technology, reduces environmental impact with 68% compared to R-410A, leads directly to lower energy consumption thanks to its high energy efficiency and has up to lower 16% refrigerant charge
- › Automatic filter cleaning results in higher efficiency & comfort and lower maintenance costs. 2 filters available: standard filter and finer mesh filter (for fine dust applications e.g. clothing shops)
- › Two optional intelligent sensors improve energy efficiency and comfort
- › Individual flap control: flexibility to suit every room layout without changing the location of the unit!
- › Lowest installation height in the market: 214mm
- › Modern style decoration panel is available in 3 different variations: white (RAL9010) with grey louvers, full white (RAL9010) or auto cleaning panel



Indoor units

Efficiency data		FCAG + RXM		35A + 35M9	50A + 50M9	60A + 60M9	
Cooling capacity	Nom.	kW		3.50	5.00	5.70	
Heating capacity	Nom.	kW		4.20	6.00	7.00	
Power input	Cooling	Nom.	kW	0.94	1.39	1.72	
	Heating	Nom.	kW	1.11	1.62	2.07	
Seasonal efficiency (according to EN14825)	Cooling	Energy efficiency class		A++			
		Pdesign	kW	3.50	5.00	5.70	
		SEER		6.35	6.54	6.40	
	Heating (Average climate)	Annual energy consumption		kWh	193	266	312
		Energy efficiency class			A++	A+	
		Pdesign	kW	3.32	4.36	4.71	
	SCOP/A		4.90	4.30	4.20		
	Annual energy consumption		kWh	948	1,419	1,569	
Indoor unit		FCAG		35A	50A	60A	
Dimensions	Unit	HeightxWidthxDepth		mm			
				18	204x840x840	19	
Weight	Unit			kg			
Air filter	Type			Resin net			
Decoration panel	Model			BYCQ140DGF9 - auto cleaning panel with fine mesh filter / BYCQ140DG9 - auto cleaning panel / BYCQ140DW - full white / BYCQ140D - white with grey louvers			
		Colour			Pure White (RAL 9010)		
	Dimensions	HeightxWidthxDepth		mm			
				130x950x950 / 130x950x950 / 50x950x950 / 50x950x950			
	Weight			kg			
				10.3 / 10.3 / 5.4 / 5.4			
Fan	Air flow rate	Cooling	Low/Medium/High	m ³ /min	8.7/10.6/12.5	8.7/10.7/12.6	8.7/11.2/13.6
		Heating	Low/Medium/High	m ³ /min	9.3/11.6/13.9	8.7/10.7/12.6	8.7/11.2/13.6
Sound power level	Cooling			dBA	49	51	
	Heating			dBA	49	51	
Sound pressure level	Cooling	Low/High			dBA	27/31	28/33
	Heating	Low/High			dBA	27/31	28/33
Control systems	Infrared remote control				BRC7FA532F		
	Wired remote control				BRC1H51 / BRC1E53A / BRC1E53B / BRC1E53C / BRC1D52		
Power supply	Phase/Frequency/Voltage				Hz/V		
					1~/50/60/220-240/220		
Outdoor unit		RXM		35M9	50M9	60M9	
Dimensions	Unit	HeightxWidthxDepth		mm			
				550x765x285	735x825x300		
Weight	Unit			kg			
				32	47		
Sound power level	Cooling			dBA			
	Heating			dBA			
				61	62	63	
				61	62	63	
Operation range	Cooling	Ambient	Min.~Max.	°CDB	-10~-46		
	Heating	Ambient	Min.~Max.	°CWB	-15~-18		
Refrigerant	Type			R-32			
	GWP			675.0			
	Charge			kg/CO ₂ Eq	0.76/0.52	1.40/0.95	1.45/0.98
Piping connections	Liquid	OD			mm		
					6.35	6.4	12.7
	Gas	OD			mm		
					9.50		30
	Piping length	OU - IU	Max.	m			
				20.0			
	Additional refrigerant charge				kg/m		
					0.02 (for piping length exceeding 10m)		
	Level difference	IU - OU	Max.	m			
				20.0			
Power supply	Phase/Frequency/Voltage				Hz/V		
					1~/50/220-240		
Current - 50Hz	Maximum fuse amps (MFA)				A		
					10	15	

(1) EER/COP according to Eurovent 2012, for use outside EU only

(2) BYCQ140D7W1: pure white standard panel with grey louvers; BYCQ140D7W1W: pure white standard panel with white louvers; BYCQ140D7GW1: pure white auto cleaning panel.

(3) The BYCQ140D7W1W has white insulations. Be informed that formation of dirt on white insulation is visibly stronger and that it is consequently not advised to install the BYCQ140D7W1W decoration panel in environments exposed to concentrations of dirt.

(4) MFA is used to select the circuit breaker and the ground fault circuit interrupter (earth leakage circuit breaker). For more detailed information on each combination, please refer to the electrical data drawing.

Fully Flat Cassette

Design & Genius in one



Why choose fully flat cassette

- Unique design in the market that integrates fully flat into the ceiling
- Advanced technology and top efficiency combined
- Most quiet cassette available on the market

FFA-A



Choice between grey or white panel

Benefits for the installer

- > Unique product in the market!
- > Most quiet unit (25dBA)
- > The user-friendly remote control, available in several languages, enables the easy set-up of sensor option and control of the individual flap position
- > Meeting European design taste.

Benefits for the consultant

- > Unique product in the market!
- > Blends seamlessly in any modern office interior design
- > Ideal product to improve BREEAM score/EPBD in combination with Sky Air (FFA-A) or VRV IV heat pump units (FXZQ-A).

Benefits for the end user

- > Engineering excellence and unique design in one
- > Most quiet unit (25dBA)
- > Perfect working conditions: no more cold draughts
- > Save up to 27% on your energy bill thanks to the optional sensors
- > Flexible usage of space and suits any room configuration thanks to individual flap control
- > User-friendly remote control, available in several languages.



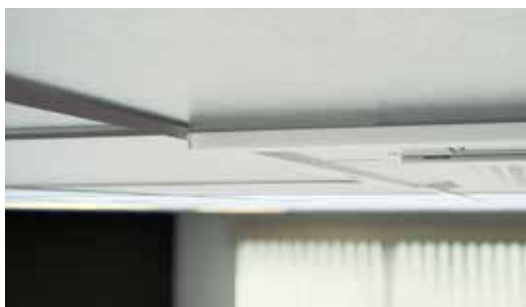

Unique design

- › Designed by a European design office to fully meet the European taste.
- › Fully flat into the ceiling, leaving only 8mm.



- › Fully integrated in the one ceiling tile, enabling lights, speakers and sprinklers to be installed in adjoining ceiling tiles.
- › Decoration panel available in 2 colours (white and white-silver).



Differentiating in technology

Optional presence sensor

- › When the room is empty, it can adjust the set temperature or switch off the unit – saving energy.
- › When people are detected, the direction of the airflow is adapted to avoid cold draughts



being directed towards occupants.

Optional floor sensor

- › Detects the temperature difference and re-directs the airflow to ensure even temperature distribution.

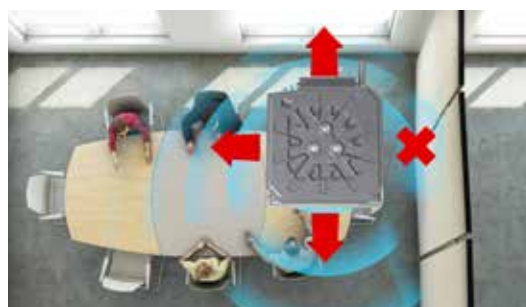

Top efficiency

- › Seasonal efficiency labels up to **A++** *
- › When the room is empty, the sensor option can adjust the set temperature or switch off the unit – saving up to 27% energy.

* for FFA25,35A in combination with RXM25,35M9

Other benefits

- › Individual flap control: easily control one or more flaps via the wired remote controller (BRC1E*) when rearranging the room. When fully closing or blocking the flaps, the option “Sealing member of air discharge outlet” is needed.
- › Most silent cassette in the market (25dBA), important for office applications.



Marketing tools

- › https://www.daikin.eu/en_us/product-group/fully-flat-cassette.html
- › www.youtube.com/DaikinEurope



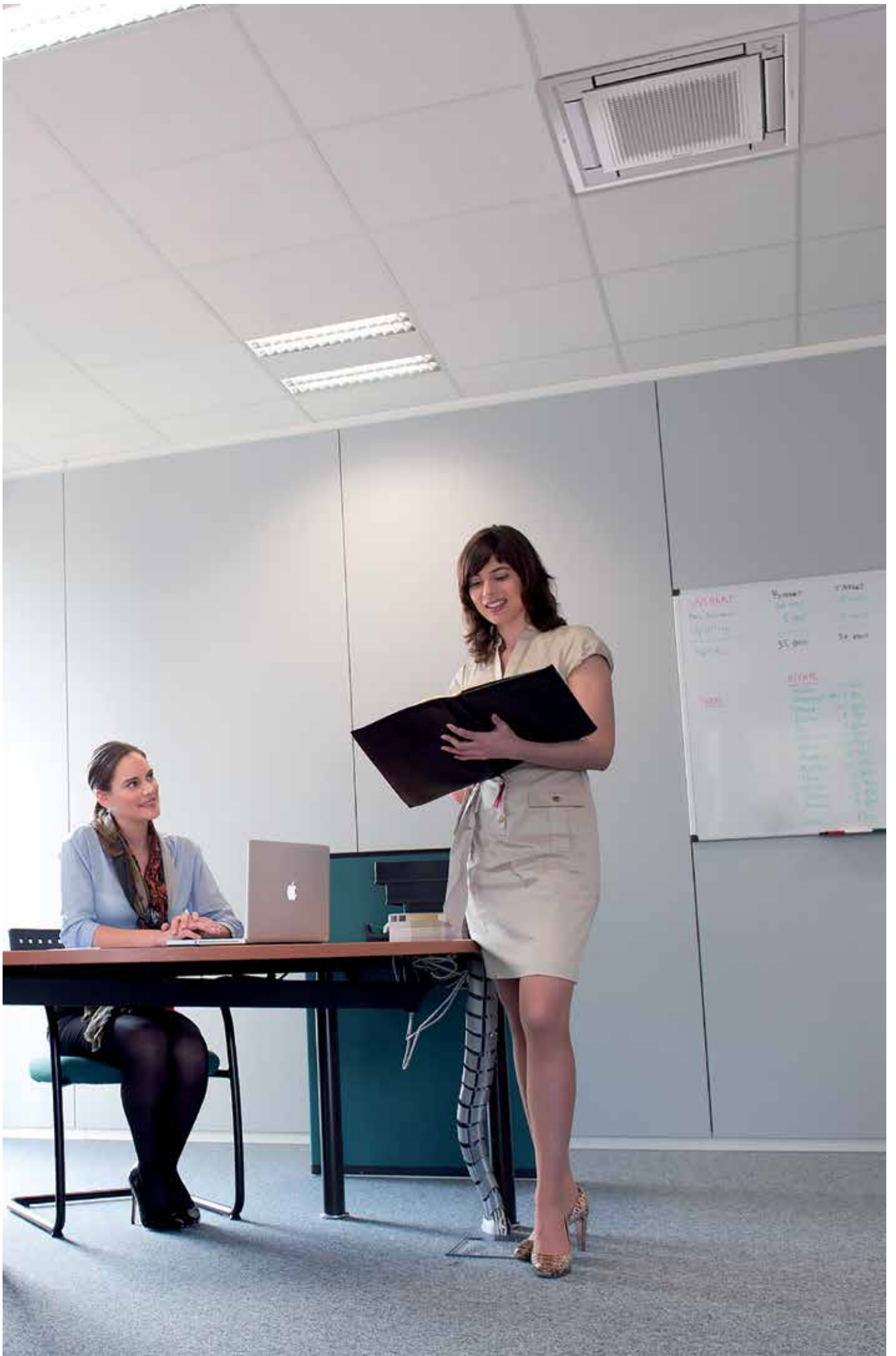

Fully flat cassette

Unique design in the market that integrates fully flat into the ceiling

- > Fully flat integration in standard architectural ceiling tiles, leaving only 8mm
- > Remarkable blend of iconic design and engineering excellence with an elegant finish in white or a combination of silver and white
- > Unified indoor unit range for R-32 and R-410A
- > Combining with R-32 Bluevolution technology, reduces environmental impact with 68% compared to R-410A, leads directly to lower energy consumption thanks to its high energy efficiency and has up to lower 16% refrigerant charge
- > Two optional intelligent sensors improve energy efficiency and comfort

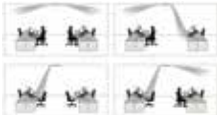

- > Individual flap control: flexibility to suit every room layout without changing the location of the unit!
- > Reduced energy consumption thanks to specially developed small tube heat exchanger, DC fan motor and drain pump
- > Optional fresh air intake
- > Branch duct discharge allows to optimize air distribution in irregular shaped rooms or to supply air to small adjacent rooms
- > Standard drain pump with 630mm lift increases flexibility and installation speed



Indoor units

Efficiency data		FFA + RXM		25A + 25M9	35A + 35M9	50A + 50M9	60A + 60M9	
Cooling capacity	Nom.	kW		2.50	3.40	5.00	5.70	
Heating capacity	Nom.	kW		3.20	4.20	5.80	7.00	
Power input	Cooling	Nom.	kW	0.55	0.89	1.54	1.87	
	Heating	Nom.	kW	0.82	1.20	1.66	2.05	
Seasonal efficiency (according to EN14825)	Cooling	Energy efficiency class		A++				
		Pdesign	kW	2.50	3.40	5.00	5.70	
		SEER		6.17	6.38	5.98	5.76	
		Annual energy consumption	kWh	142	186	292	347	
	Heating (Average climate)	Energy efficiency class		A+				
		Pdesign	kW	2.31	3.10	3.84	3.96	
		SCOP/A		4.24	4.10	3.90	4.04	
		Annual energy consumption	kWh	762	1,058	1,377	1,372	
Indoor unit		FFA		25A	35A	50A	60A	
Dimensions	Unit	HeightxWidthxDepth	mm	260x575x575				
Weight	Unit	kg		16.0		17.5		
Air filter	Type	Resin net						
Decoration panel	Model	BYFQ60C2W1W/BYFQ60C2W1S/BYFQ60B2W1/BYFQ60B3W1						
	Colour	White (N9.5)/SILVER/White (RAL9010)/WHITE (RAL9010)						
	Dimensions	HeightxWidthxDepth	mm	46x620x620 / 46x620x620 / 55x700x700 / 55x700x700				
	Weight	kg		2.8/2.8/2.7/2.7				
Fan	Air flow rate	Cooling	Low/Medium/High	m ³ /min	6.5/8.0/9.0	6.5/8.5/10.0	7.5/10.0/12.0	9.5/12.5/14.5
		Heating	Low/Medium/High	m ³ /min	6.5/8.0/9.0	6.5/8.5/10.0	7.5/10.0/12.0	9.5/12.5/14.5
Sound power level	Cooling	dBA		48	51	56	60	
Sound pressure level	Cooling	Low/High	dBA	25.0/31.0	25.0/34.0	27.0/39.0	32.0/43.0	
	Heating	Low/High	dBA	25.0/31.0	25.0/34.0	27.0/39.0	32.0/43.0	
Control systems	Infrared remote control		BRC7EB530W (standard panel) / BRC7F530W (white panel) / BRC7F530S (grey panel)					
	Wired remote control		BRC1H51 / BRC1E53A / BRC1E53B / BRC1E53C / BRC1D52					
Power supply	Phase/Frequency/Voltage		Hz/V					
			1~/50/220-240					
Outdoor unit		RXM		25M9	35M9	50M9	60M9	
Dimensions	Unit	HeightxWidthxDepth	mm	550x765x285		735x825x300		
Weight	Unit	kg		32		47		
Sound power level	Cooling	dBA		59	61	62	63	
	Heating	dBA		59	61	62	63	
Operation range	Cooling	Ambient	Min.~Max.	°CDB				
	Heating	Ambient	Min.~Max.	°CWB				
Refrigerant	Type	R-32						
	GWP	675.0						
	Charge	kg/TCO2Eq		0.76/0.52		1.40/0.95		
Piping connections	Liquid	OD	mm	6,35		6,4		
	Gas	OD	mm	9,50		12,7		
	Piping length	OU - IU	Max.	m		30		
		System	Chargeless	m		-		
		Additional refrigerant charge	kg/m		0.02 (for piping length exceeding 10m)			
Power supply	Phase/Frequency/Voltage		Hz/V					
			1~/50/220-240					
Current - 50Hz	Maximum fuse amps (MFA)		A		10		15	

(1) EER/COP according to Eurovent 2012, for use outside EU only.

(2) MFA is used to select the circuit breaker and the ground fault circuit interrupter (earth leakage circuit breaker). For more detailed information on each combination, please refer to the electrical data drawing.



Auto cleaning filter for concealed ceiling units

The unique automatic cleaning filter achieves higher efficiency and comfort with lower maintenance costs

Reduce running costs

- › Automatic filter cleaning ensures low maintenance costs because the filter is always clean

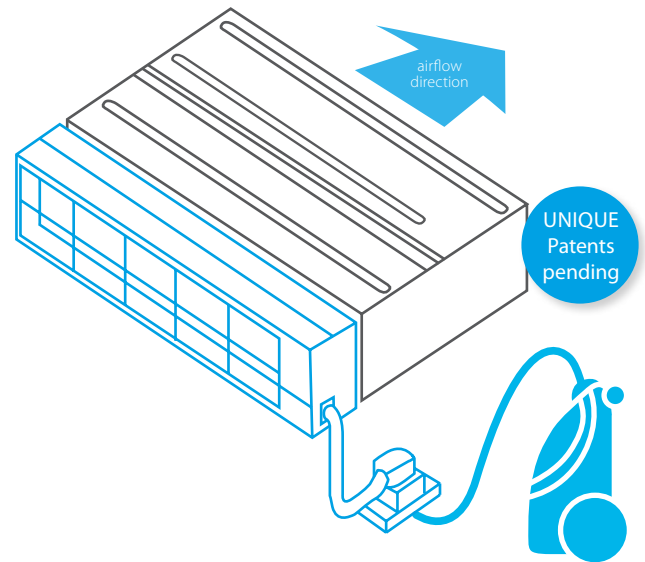
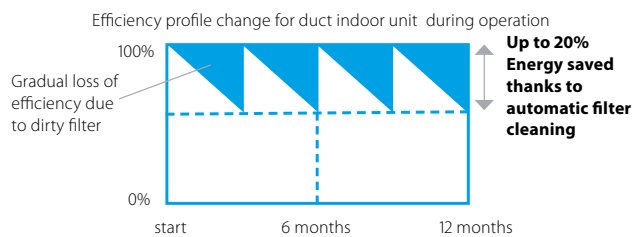

Minimal time required for filter cleaning

- › The dust box can be emptied with a vacuum cleaner for fast and easy cleaning
- › No more dirty ceilings

Improved indoor air quality

- › Optimum airflow eliminates draft and insulates sound

Superb reliability

- › Prevents clogged filters for seamless operation

Unique technology

- › Unique and innovative filter technology inspired by the Daikin auto cleaning cassette



How does it work?

- 1 Scheduled automatic filter cleaning
- 2 Dust collects in a dust box that's integrated into the unit
- 3 The dust can easily be removed with a vacuum cleaner

Combination table

	Split / Sky Air				VRV						
	FDXM-F3				FXDQ-A3						
	25	35	50	60	15	20	25	32	40	50	63
BAE20A62	•	•			•	•	•	•			
BAE20A82									•	•	
BAE20A102			•	•							•

Specifications

	BAE20A62	BAE20A82	BAE20A102
Height (mm)	212		
Width (mm)	764	964	1164
Width (mm) (incl. hanger bracket)	984	1094	1294
Depth (mm)	201		

Multi zoning kit for concealed ceiling units



Indoor units

The multi-zoning system is a room-by-room controller. It is fitted with motorised dampers, which immediately adapt using Daikin ducted solutions. This system supports control of up to 8 zones via a centralised thermostat located in the main room and individual thermostats for each of the zones.

Benefits

Increased comfort

- › Increases comfort levels by allowing more individual zone control
 - Up to 8 individual zones can be served thanks to separate modulating dampers
 - Individual thermostat for room-by-room or zone-by-zone control

Easy to install

- › Automatic air flow adjustment according to the demand
- › Easy to install, integrates with the Daikin indoor units and system controls
- › Time saving as plenum comes fully pre-assembled with dampers, and control boards
- › Reduces the amount of refrigerant required in the installation

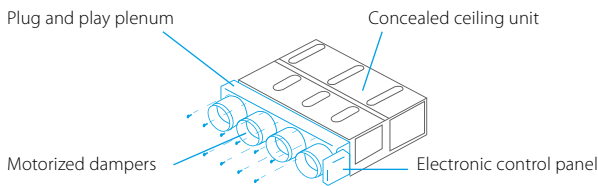

How does it work?

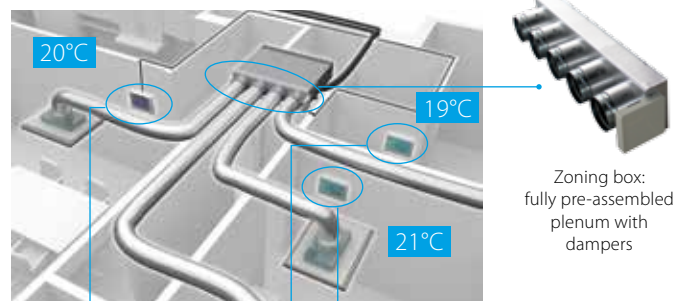

Individual zone thermostats

Blueface - Airzone Main Thermostat

- › Color graphic interface for controlling zones
- › Wired communication



AZCE6BLUEFACECB

Airzone Zone Thermostat

- › Graphic interface with low-energy e-ink screen for controlling zones
- › Radio communication



AZCE6THINKRB

Airzone Zone Thermostat

- › Thermostat with buttons for controlling the temperature
- › Radio communication



AZCE6LITERB

Compatibility

			SkyAir												VRV																								
			FDXM-F3				FBA-A				ADEQ-C				FXDQ-A3						FXSQ-A																		
Number of motorised dampers	Reference	Dimensions H x L x D (mm)	25	35	50	60	35	50	60	71	100	125	140	71	100	125	15	20	25	32	40	50	63	15	20	25	32	40	50	63	71	80	100	125	140				
Standard Ceiling Void	2	AZEZ6DAIST07XS2	930 x 300 x 454					•	•																	•	•	•	•										
		AZEZ6DAIST07S2																																					
		AZEZ6DAIST07XS3	930 x 300 x 454																																				
		AZEZ6DAIST07S3																																					
		AZEZ6DAIST07S4	930 x 300 x 454																																				
		AZEZ6DAIST07M4	1,140 x 300 x 454																																				
		AZEZ6DAIST07M5	1,425 x 300 x 454																																				
		AZEZ6DAIST07L5																																					
		AZEZ6DAIST07M6	1,638 x 300 x 454																																				
		AZEZ6DAIST07L6																																					
Compact Ceiling Void	2	AZEZ6DAISL01S2	720 x 210 x 444	•	•																																		
		AZEZ6DAISL01S3	720 x 210 x 444	•	•																																		
		AZEZ6DAISL01M4	930 x 210 x 444																																				
		AZEZ6DAISL01M4	930 x 210 x 444																																				
		AZEZ6DAISL01L5	1,140 x 210 x 444																																				
		AZEZ6DAISL01S2	720 x 210 x 444																																				
		AZEZ6DAISL01S3	720 x 210 x 444																																				
		AZEZ6DAISL01M4	930 x 210 x 444																																				
		AZEZ6DAISL01L5	1,140 x 210 x 444																																				

Concealed ceiling unit

Compact concealed ceiling unit, with a height of only 200mm

- › Invisible unit as the unit is concealed in the ceiling: only the suction and discharge grilles are visible
- › Compact dimensions, can easily be mounted in a ceiling void of only 240mm

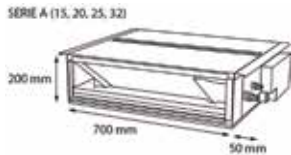

- › Medium external static pressure up to 40Pa facilitates unit use with flexible ducts of varying lengths
- › Unified indoor unit range for R-32 and R-410A
- NEW** › Auto cleaning filter option ensures maximum efficiency, comfort and reliability by regular filter cleaning
- NEW** › Multi zoning kit allows multiple individually-controlled climate zones to be served by one indoor unit
- › Online controller (optional): control your indoor from any location with an app, via your local network or internet and keep an overview on your energy consumption
- › Low energy consumption thanks to DC fan motor



Efficiency data		FDXM + RXM		25F3 + 25M9	35F3 + 35M9	50F3 + 50M9	60F3 + 60M9	
Cooling capacity	Nom.	kW		2.40	3.40	5.00	6.00	
Heating capacity	Nom.	kW		3.20	4.00	5.80	7.00	
Power input	Cooling	Nom.	kW	0.64	1.14	1.63	2.05	
	Heating	Nom.	kW	0.80	1.15	1.87	2.18	
Seasonal efficiency (according to EN14825)	Cooling	Energy efficiency class		A+	A	A+	A	
		Pdesign	kW	2.40	3.40	5.00	6.00	
		SEER		5.68	5.26	5.77	5.56	
	Annual energy consumption		kWh	148	226	303	315	
	Heating (Average climate)	Energy efficiency class		A+		A		
		Pdesign	kW	2.60	2.90	4.00	4.60	
SCOP/A			4.24	3.88	3.93	3.80		
Annual energy consumption		kWh	858	1,046	1,424	1,693		
Indoor unit		FDXM		25F3	35F3	50F3	60F3	
Dimensions	Unit	HeightxWidthxDepth		200x750x620		200x1,150x620		
Weight	Unit	kg		21		28		
Air filter	Type		Removable / washable					
Fan	Air flow rate	Cooling	Low/Medium/High	m ³ /min	7.3/8.0/8.7		13.3/14.6/15.8	13.5/14.8/16.0
		Heating	Low/Medium/High	m ³ /min	7.3/8.0/8.7		13.3/14.6/15.8	13.5/14.8/16.0
	External static pressure	Nom.	Pa	30		40		
Sound power level	Cooling	dB(A)		53		55	56	
	Heating	dB(A)		53		55	56	
Sound pressure level	Cooling	Low/High	dB(A)		27/35		30/38	
	Heating	Low/High	dB(A)		27/35		30/38	
Power supply	Phase/Frequency/Voltage		Hz/V		1~/50/220-240			
Outdoor unit		RXM		25M9	35M9	50M9	60M9	
Dimensions	Unit	HeightxWidthxDepth		550x765x285		735x825x300		
Weight	Unit	kg		32		47		
Sound power level	Cooling	dB(A)		59		62	63	
	Heating	dB(A)		59		62	63	
Operation range	Cooling	Ambient	Min.~Max.	°CDB		-10~46		
	Heating	Ambient	Min.~Max.	°CWB		-15~18		
Refrigerant	Type	R-32						
	GWP	675.0						
Piping connections	Charge	kg/TCO2Eq		0.76/0.52		1.40/0.95	1.45/0.98	
	Liquid	OD	mm		6.35		6.4	
		Gas	OD	mm		9.50		12.7
	Piping length	OU - IU	Max.	m		20.0		30
	Additional refrigerant charge	kg/m		0.02 (for piping length exceeding 10m)				
Level difference	IU - OU	Max.	m		20.0			
Power supply	Phase/Frequency/Voltage		Hz/V		1~/50/220-240			
Current - 50Hz	Maximum fuse amps (MFA)		A		10		15	

(1) EER/COP according to Eurovent 2012, for use outside EU only,

(2) MFA is used to select the circuit breaker and the ground fault circuit interrupter(earth leakage circuit breaker). For more detailed information on each combination, please refer to the electrical data drawing.

Concealed ceiling unit with medium ESP

Slimmest yet most powerful medium static pressure unit on the market

- > Combination with Sky Air Alpha-series ensures best in class quality, highest efficiency and performance
- > Slimmest unit in class, only 245mm (300mm built-in height) and therefore narrow ceiling voids are no longer a challenge



- > Low operation sound level down to 25dBA
- > Medium external static pressure up to 150Pa facilitates using flexible ducts of varying lengths
- > Unified indoor unit can be combined with R-32 and R-410A outdoor units, simplifying stock
- > Combining with R-32 Bluevolution technology, reduces environmental impact with 68% compared to R-410A, leads directly to lower energy consumption thanks to its high energy efficiency and has up to lower 16% refrigerant charge
- NEW** > Possibility to change ESP via wired remote control allows optimisation of the supply air volume
- > Discretely concealed in the ceiling: only the suction and discharge grilles are visible
- > Multi zoning kit allows multiple individually-controlled climate



- zones to be served by one indoor unit
- > Reduced energy consumption thanks to specially developed DC fan motor
- > Optional fresh air intake
- > Flexible installation: air suction direction can be altered from rear to bottom suction and choice between free use or connection to optional suction grilles
- > Standard built-in drain pump with 625mm lift increases flexibility and installation speed

Efficiency data			FBA + RZAG										
			71A + 71MV1	100A + 100MV1	125A + 125MV1	140A + 140MV1	71A + 71MY1	100A + 100MY1	125A + 125MY1	140A + 140MY1			
Cooling capacity	Nom.	kW	6.80	9.50	12.1	13.4	6.80	9.50	12.1	13.4			
Heating capacity	Nom.	kW	7.50	10.8	13.5	15.5	7.50	10.8	13.5	15.5			
Seasonal efficiency (according to EN14825)	Cooling	Energy efficiency class	A++				A++						
		Pdesign	6.80	9.50	12.1	13.4	6.80	9.50	12.1	13.4			
		SEER	6.22	6.47	6.19	6.42	6.22	6.47	6.19	6.42			
	Heating (Average climate)	Annual energy consumption	kWh	382	514	1,173	1,252	382	514	1,173	1,252		
		Energy efficiency class	A+				A+						
		Pdesign	4.70	7.80	9.52		4.70	7.80	9.52				
SCOP/A	4.20	4.36	4.12	4.11	4.20	4.36	4.12	4.11					
Annual energy consumption	kWh	1,566	2,505	3,235	3,243	1,566	2,505	3,235	3,243				
Indoor unit			FBA	71A	100A	125A	140A	71A	100A	125A	140A		
Dimensions	Unit	HeightxWidthxDepth	mm	245x1,000x800			245x1,400x800		245x1,000x800		245x1,400x800		
Weight	Unit		kg	35.0			46.0		35.0		46.0		
Air filter	Type		Resin net										
Fan	Air flow rate	Cooling	Low/Medium/High	m ³ /min		12.5/15.0/18.0	23.0/26.0/29.0	23.5/29.0/34.0		12.5/15.0/18.0	23.0/26.0/29.0	23.5/29.0/34.0	
		Heating	Low/Medium/High	m ³ /min		12.5/15.0/18.0	23.0/26.0/29.0	23.5/29.0/34.0		12.5/15.0/18.0	23.0/26.0/29.0	23.5/29.0/34.0	
	External static pressure	Nom./High	Pa	30/150		40/150		50/150		30/150		40/150	
Sound power level	Cooling		dBA	56		58		62		56		58	
Sound pressure level	Cooling	Low/High	dBA	25.0/30.0		30.0/34.0		32.0/37.0		25.0/30.0		30.0/34.0	
	Heating	Low/High	dBA	25.0/31.0		30.0/36.0		32.0/38.0		25.0/31.0		30.0/36.0	
Control systems	Infrared remote control		BRC4C65 / BRC4C66										
	Wired remote control		BRC1H51 / BRC1E53A / BRC1E53B / BRC1E53C / BRC1D52										
Power supply	Phase/Frequency/Voltage		Hz/V										
			1~/50/60/220-240/220										
Outdoor unit			RZAG	71MV1	100MV1	125MV1	140MV1	71MY1	100MY1	125MY1	140MY1		
Dimensions	Unit	HeightxWidthxDepth	mm	990x940x320			1,430x940x320		990x940x320		1,430x940x320		
Weight	Unit		kg	70			92		70		92		
Sound power level	Cooling		dBA	64		66		69		70			
Sound pressure level	Cooling	Nom.	dBA	46		47		50		51			
	Heating	Nom.	dBA	49		51		52		49			
Operation range	Cooling	Ambient	Min.~Max.	°CDB									
	Heating	Ambient	Min.~Max.	°CWB									
Refrigerant	Type/GWP		R-32/675										
	Charge		kg/TCO2Eq	2.95/1.99			3.75/2.53		2.95/1.99		3.75/2.53		
Piping connections	Liquid/Gas		mm	9.52/15.9									
	Piping length	OU - IU	Max.	m			85		55		85		
		System	Equivalent	m			75		75		100		
	Chargeless		m	40									
	Additional refrigerant charge		kg/m	See installation manual									
Power supply	Level difference		IU - OU	Max.									
	Phase/Frequency/Voltage		Hz/V	1~/50/220-240				3~/50/380-415					
Current - 50Hz	Maximum fuse amps (MFA)		A	20			32		16				

(1) EER/COP according to Eurovent 2012, for use outside EU only
 (2) MFA is used to select the circuit breaker and the ground fault circuit interrupter (earth leakage circuit breaker). For more detailed information on each combination, please refer to the electrical data drawing.

Concealed ceiling unit with medium ESP

Slimmest yet most powerful medium static pressure unit on the market

- > Combination with Sky Air Advance-series ensures good value for money for all types of commercial applications
- > Slimmest unit in class, only 245mm (300mm built-in height)
- > Low operation sound level down to 25dBA
- > Medium external static pressure up to 150Pa facilitates using flexible ducts of varying lengths
- > Unified indoor unit can be combined with R-32 and R-410A outdoor units, simplifying stock
- > Combining with R-32 Bluevolution technology, reduces environmental impact with 68% compared to R-410A
- > Possibility to change ESP via wired remote control allows optimisation of the supply air volume
- > Discretely concealed in the ceiling: only the suction and discharge grilles are visible
- > Multi zoning kit allows multiple individually-controlled climate zones to be served by one indoor unit

NEW



Optimised supply air volume

Automatically selects the most appropriate fan curve to achieve the units' nominal air flow within ±10%

Why?

After installation the real ducting will frequently differ from the initially calculated air flow resistance → the real air flow may be much lower or higher than nominal, leading to a lack of capacity or uncomfortable air temperature

Automatic Airflow Adjustment function will adapt the unit's fan speed to any ducting automatically (10 or more fan curves are available on every model), making installation much faster

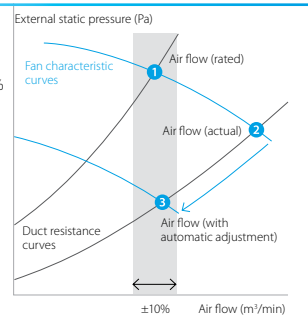

Efficiency data				FBA + RZASG	71A + 71MV1	100A + 100MV1	125A + 125MV1	140A + 140MV1	100A + 100MY1	125A + 125MY1	140A + 140MY1				
Cooling capacity	Nom.			kW	6.80	9.50	12.1	13.4	9.50	12.1	13.4				
Heating capacity	Nom.			kW	7.50	10.8	13.5	15.5	10.8	13.5	15.5				
Seasonal efficiency (according to EN14825)	Cooling	Energy efficiency class			A++	A+	-	-	A+	-	-				
		Pdesign	kW	6.80	9.50	12.1	13.4	9.50	12.1	13.4					
		SEER		6.19	5.83	5.47	5.81	5.83	5.47	5.81					
	Heating (Average climate)	Annual energy consumption		kWh	385	570	1,378	1,384	570	1,378	1,384				
		Energy efficiency class			A+	A	-	-	A	-	-				
		Pdesign	kW	4.50	6.00	7.80	6.00	7.80							
SCOP/A		4.01	3.85	3.63	3.85	3.63	3.85								
Annual energy consumption	kWh	1,571	2,182	2,314	2,836	2,182	2,314	2,836							
Indoor unit				FBA	71A	100A	125A	140A	100A	125A	140A				
Dimensions	Unit	HeightxWidthxDepth		mm	245x1,000x800		245x1,400x800								
Weight	Unit			kg	35.0		46.0								
Air filter	Type				Resin net										
Fan	Air flow rate	Cooling	Low/Medium/High	m³/min	12.5/15.0/18.0	23.0/26.0/29.0	23.5/29.0/34.0		23.0/26.0/29.0		23.5/29.0/34.0				
		Heating	Low/Medium/High	m³/min	12.5/15.0/18.0	23.0/26.0/29.0	23.5/29.0/34.0		23.0/26.0/29.0		23.5/29.0/34.0				
	External static pressure	Nom./High	Pa	30/150	40/150	50/150		40/150		50/150					
Sound power level	Cooling			dBA	56	58	62		58		62				
Sound pressure level	Cooling	Low/High		dBA	25.0/30.0	30.0/34.0	32.0/37.0		30.0/34.0		32.0/37.0				
	Heating	Low/High		dBA	25.0/31.0	30.0/36.0	32.0/38.0		30.0/36.0		32.0/38.0				
Control systems	Infrared remote control				BRC4C65 / BRC4C66										
	Wired remote control				BRC1H51 / BRC1E53A / BRC1E53B / BRC1E53C / BRC1D52										
Power supply	Phase/Frequency/Voltage				1~/50/60/220-240/220										
Outdoor unit				RZASG	71MV1	100MV1	125MV1	140MV1	100MY1	125MY1	140MY1				
Dimensions	Unit	HeightxWidthxDepth		mm	770x900x320		990x940x320								
Weight	Unit			kg	60		70		78		77				
Sound power level	Cooling			dBA	65		70		71		73				
Sound pressure level	Cooling	Nom.		dBA	46		53		54		53				
	Heating	Nom.		dBA	47		57		57		57				
Operation range	Cooling	Ambient	Min.~Max.	°CDB	-15~46										
	Heating	Ambient	Min.~Max.	°CWB	-15~15.5										
Refrigerant	Type/GWP				R-32/675										
Piping connections	Charge				kg/CO2Eq	2.45/1.65		2.60/1.76		2.90/1.96		2.60/1.76		2.90/1.96	
	Liquid/Gas			mm	9.52/15.9										
Piping length	OU - IU	System	Max.	m	50										
			Equivalent	m	70										
	Chargeless			m	30										
		Additional refrigerant charge		kg/m	See installation manual										
Level difference	IU - OU	Max.	m	30.0											
Power supply	Phase/Frequency/Voltage				1~/50/220-240										
Current - 50Hz	Maximum fuse amps (MFA)				A	20	25	32	16	20	16				

(1) EER/COP according to Eurovent 2012, for use outside EU only

(2) MFA is used to select the circuit breaker and the ground fault circuit interrupter (earth leakage circuit breaker). For more detailed information on each combination, please refer to the electrical data drawing.

Concealed ceiling unit with medium ESP

Slimmest yet most powerful medium static pressure unit on the market

- › Ideal solution for small businesses and shops
- › Slimmest unit in class, only 245mm (300mm built-in height)
- › Low operation sound level down to 25dBA
- › Medium external static pressure up to 150Pa facilitates using flexible ducts of varying lengths
- › Unified indoor unit can be combined with R-32 and R-410A outdoor units, simplifying stock
- › Combining with R-32 Bluevolution technology, reduces environmental impact with 68% compared to R-410A
- › Possibility to change ESP via wired remote control allows optimisation of the supply air volume
- › Discretely concealed in the ceiling: only the suction and discharge grilles are visible
- › Multi zoning kit allows multiple individually-controlled climate zones to be served by one indoor unit

NEW



Indoor units

Efficiency data			FBA + AZAS	71A + 71MV1	100A + 100MV1	125A + 125MV1	140A + 140MV1	100A + 100MY1	125A + 125MY1	140A + 140MY1	
Cooling capacity	Nom.		kW	6.80	9.50	12.1	13.4	9.50	12.1	13.4	
Heating capacity	Nom.		kW	7.50	10.8	13.5	15.5	10.8	13.5	15.5	
Seasonal efficiency (according to EN14825)	Cooling	Energy efficiency class		A			A			-	
		Pdesign	kW	6.80	9.50	12.1	13.0	9.50	12.1	13.0	
		SEER		5.57	5.25	4.85	5.50	5.25	4.85	5.50	
	Heating (Average climate)	Annual energy consumption	kWh	427	633	1,497	1,418	633	1,497	1,418	
		Energy efficiency class		A			A			-	
		Pdesign	kW	4.50	6.00	7.80	7.80	6.00	7.80		
SCOP/A		3.81	3.55	3.85	3.81	3.55	3.85				
Annual energy consumption	kWh	1,654	2,205	2,366	2,836	2,205	2,366	2,836			
Indoor unit			FBA	71A	100A	125A	140A	100A	125A	140A	
Dimensions	Unit	HeightxWidthxDepth	mm	245x1,000x800	245x1,400x800						
Weight	Unit		kg	35.0	46.0						
Air filter	Type			Resin net							
Fan	Air flow rate	Cooling	Low/Medium/High	m ³ /min	12.5/15.0/18.0	23.0/26.0/29.0	23.5/29.0/34.0	23.0/26.0/29.0	23.5/29.0/34.0		
		Heating	Low/Medium/High	m ³ /min	12.5/15.0/18.0	23.0/26.0/29.0	23.5/29.0/34.0	23.0/26.0/29.0	23.5/29.0/34.0		
	External static pressure	Nom./High	Pa	30/150	40/150	50/150	40/150	50/150			
Sound power level	Cooling		dBA	56	58	62	58	62			
Sound pressure level	Cooling	Low/High	dBA	25.0/30.0	30.0/34.0	32.0/37.0	30.0/34.0	32.0/37.0			
	Heating	Low/High	dBA	25.0/31.0	30.0/36.0	32.0/38.0	30.0/36.0	32.0/38.0			
Control systems	Infrared remote control			BRC4C65 / BRC4C66							
	Wired remote control			BRC1H51 / BRC1E53A / BRC1E53B / BRC1E53C / BRC1D52							
Power supply	Phase/Frequency/Voltage		Hz/V	1~/50/60/220-240/220							
Outdoor unit			AZAS	71MV1	100MV1	125MV1	140MV1	100MY1	125MY1	140MY1	
Dimensions	Unit	HeightxWidthxDepth	mm	770x900x320	990x940x320						
Weight	Unit		kg	60	70	71	78	70	71	77	
Sound power level	Cooling		dBA	65	70	71	73	70	71	73	
Sound pressure level	Cooling	Nom.	dBA	46	53	54	54	53	54		
	Heating	Nom.	dBA	47	57						
Operation range	Cooling	Ambient	Min.~Max.	°CDB			-5~-46				
	Heating	Ambient	Min.~Max.	°CWB			-15~-15.5				
Refrigerant	Type/GWP			R-32/675							
	Charge		kg/CO ₂ Eq	2.45/1.65	2.60/1.76	2.90/1.96	2.60/1.76	2.90/1.96			
Piping connections	Liquid/Gas		mm	9.52/15.9							
	Piping length	OU - IU	Max.	m							
		System	Equivalent	m							
		Chargeless		m							
	Additional refrigerant charge		kg/m	See installation manual							
Power supply	Phase/Frequency/Voltage		Hz/V	1~/50/220-240				3~/50/380-415			
Current - 50Hz	Maximum fuse amps (MFA)		A	20	25	32	16	20			

(1) EER/COP according to Eurovent 2012, for use outside EU only

(2) MFA is used to select the circuit breaker and the ground fault circuit interrupter (earth leakage circuit breaker). For more detailed information on each combination, please refer to the electrical data drawing.

Concealed ceiling unit with medium ESP

Slimmest yet most powerful medium static pressure unit on the market

- > Combination with split outdoor units is ideal for small retail, offices or residential applications
- > Slimmest unit in class, only 245mm (300mm built-in height)
- > Low operation sound level down to 25dBA
- > Medium external static pressure up to 150Pa facilitates using flexible ducts of varying lengths
- > Unified indoor unit can be combined with R-32 and R-410A outdoor units, simplifying stock
- > Combining with R-32 Bluevolution technology, reduces environmental impact with 68% compared to R-410A
- > Possibility to change ESP via wired remote control allows optimisation of the supply air volume
- > Discretely concealed in the ceiling: only the suction and discharge grilles are visible
- NEW** > Multi zoning kit allows multiple individually-controlled climate zones to be served by one indoor unit



Optimised supply air volume

Automatically selects the most appropriate fan curve to achieve the units' nominal air flow within ±10%

Why?

After installation the real ducting will frequently differ from the initially calculated air flow resistance → the real air flow may be much lower or higher than nominal, leading to a lack of capacity or uncomfortable air temperature

Automatic Airflow Adjustment function will adapt the unit's fan speed to any ducting automatically (10 or more fan curves are available on every model), making installation much faster

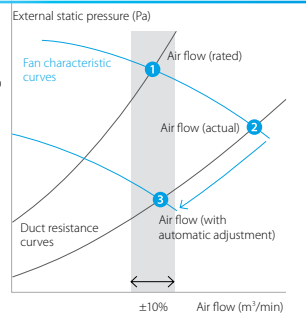

Efficiency data		FBA + RXM	35A + 35M9	50A + 50M9	60A + 60M9	
Cooling capacity	Nom.	kW	3.40	5.00	5.70	
Heating capacity	Nom.	kW	4.00	5.50	7.00	
Power input	Cooling	Nom. kW	0.85	1.41	1.64	
	Heating	Nom. kW	1.00	1.44	1.89	
Seasonal efficiency (according to EN14825)	Cooling	Energy efficiency class	A++		A+	
		Pdesign	kW	3.40	5.00	5.70
		SEER		6.23	6.27	5.91
		Annual energy consumption	kWh	191	279	337
	Heating (Average climate)	Energy efficiency class	A+		A+	
		Pdesign	kW	2.90	4.40	4.60
SCOP/A			4.07	4.06	4.01	
	Annual energy consumption	kWh	996	1,517	1,607	
Indoor unit		FBA	35A	50A	60A	
Dimensions	Unit	HeightxWidthxDepth	245x700x800		245x1,000x800	
Weight	Unit		28.0		35.0	
Air filter	Type		Resin net			
Fan	Air flow rate	Cooling	Low/Medium/High		m³/min	
		Heating	Low/Medium/High		m³/min	
	External static pressure	Nom./High			Pa	
Sound power level	Cooling		60		56	
Sound pressure level	Cooling	Low/High	29.0/35.0		25.0/30.0	
	Heating	Low/High	29.0/37.0		25.0/31.0	
Control systems	Infrared remote control		BRC4C65 / BRC4C66			
	Wired remote control		BRC1H51 / BRC1E53A / BRC1E53B / BRC1E53C / BRC1D52			
Power supply	Phase/Frequency/Voltage	Hz/V	1~/50/60/220-240/220			
Outdoor unit		RXM	35M9	50M9	60M9	
Dimensions	Unit	HeightxWidthxDepth	550x765x285		735x825x300	
Weight	Unit		32		47	
Sound power level	Cooling		61		63	
	Heating		61		63	
Operation range	Cooling	Ambient	Min.~Max.	-10~-46		
	Heating	Ambient	Min.~Max.	-15~-18		
Refrigerant	Type		R-32			
	GWP		675.0			
Piping connections	Charge		kg/CO2Eq			
	Liquid	OD	mm		6,4	
	Gas	OD	mm		12,7	
	Piping length	OU - IU	Max.	m		
	Additional refrigerant charge			kg/m		
Power supply	Phase/Frequency/Voltage	Hz/V	1~/50/220-240			
	Current - 50Hz	Maximum fuse amps (MFA)	A	10		

(1) EER/COP according to Eurovent 2012, for use outside EU only

(2) MFA is used to select the circuit breaker and the ground fault circuit interrupter (earth leakage circuit breaker). For more detailed information on each combination, please refer to the electrical data drawing.

Concealed ceiling unit with high ESP

ESP up to 200, ideal for large sized spaces

- › Unified range for R-32 and R-410A simplifying stock
- › High external static pressure up to 200Pa facilitates extensive duct and grille network
- › Possibility to change ESP via wired remote control allows optimisation of the supply air volume
- › Discretely concealed in the ceiling: only the suction and discharge grilles are visible
- › Reduced energy consumption thanks to specially developed DC fan motor
- › No optional adapter needed for DIII-connection, link your unit into the wider building management system.
- › Flexible installation, as the air suction direction can be altered from rear to bottom suction
- › Standard built-in drain pump with 625mm lift increases flexibility and installation speed



Indoor units

Efficiency data			FDA + RZAG/RZASG	Sky Air Alpha-series		Sky Air Advance-series		
				125A + 125MV1	125A + 125MY1	125A + 125MV1	125A + 125MY1	
Cooling capacity	Nom.						12.1	
Heating capacity	Nom.						13.5	
Seasonal efficiency (according to EN14825)	Cooling	Energy efficiency class						
		Pdesign						
		SEER		6.59			5.03	
	Heating (Average climate)	Annual energy consumption	kWh		1,102			1,444
		Energy efficiency class						
		Pdesign	kW		9.52			6.00
	SCOP/A			4.08			3.58	
	Annual energy consumption	kWh		3,267			2,346	

Indoor unit			FDA	125A
Dimensions	Unit	HeightxWidthxDepth	mm	300x1,400x700
Required ceiling void >			mm	350
Weight	Unit		kg	45
Decoration panel	Model			BYBS125DJW1
	Colour			White (10Y9/0.5)
	Dimensions	HeightxWidthxDepth	mm	55x1,500x500
	Weight		kg	6.5
Air filter	Type			Resin net
Fan - Air flow rate	Cooling	High/Low	m ³ /min	39/28
	Heating	High/Low	m ³ /min	39/28
Fan - External static pressure	High/Nom./Maximum available/High		Pa	200/50/-
Sound power level	Cooling		dBA	66
Sound pressure level	Cooling	High/Low	dBA	40/33
	Heating	High/Low	dBA	40/33
Refrigerant	Type			R-32 / R-410A
Control systems	Infrared remote control			BRC4C65
	Wired remote control			BRC1H51 / BRC1E53A / BRC1E53B / BRC1E53C / BRC1D52
Power supply	Phase / Frequency / Voltage		Hz / V	1~ / 50/60 / 220-240/220

Outdoor unit			RZAG/RZASG	125MV1	125MY1	125MV1	125MY1
Dimensions	Unit	HeightxWidthxDepth	mm	1,430x940x320	1,430x940x320	990x940x320	990x940x320
Weight	Unit		kg	92	92	70	70
Sound power level	Cooling		dBA	69	69	71	71
	Heating	Nom.	dBA	50	50	53	53
Sound pressure level	Cooling	Nom.	dBA	52	52	57	57
	Heating	Nom.	dBA				
Operation range	Cooling	Ambient	Min.~Max.	°CDB	-20~52		-15~46
	Heating	Ambient	Min.~Max.	°CWB	-20~18		-15~15.5
Refrigerant	Type					R-32	
	Charge		kg	3,75			2,6
			TCO ₂ eq	2,53			1,76
Piping connections	Piping length	OU - IU	Max.	m	85		50
		System	Chargeless	m	40		30
Power supply	Phase / Frequency / Voltage		Hz / V	1~/50/220-240	3N~/50 / 380-415	1~/50/220-240	3N~/50 / 380-415

(1) EER/COP according to Eurovent 2012, for use outside EU only

(2) MFA is used to select the circuit breaker and the ground fault circuit interrupter (earth leakage circuit breaker). For more detailed information on each combination, please refer to the electrical data drawing.

Wall mounted unit

For rooms with no false ceilings nor free floor space

- › Combination with Sky Air Alpha-series ensures best in class quality, highest efficiency and performance
- › Flat, stylish front panel blends easily within any interior décor and is easier to clean
- › Can easily be installed in both new and refurbishment projects
- › Unified indoor unit range for R-32 and R-410A
- › Combining with R-32 Bluevolution technology, reduces environmental impact with 68% compared to R-410A, leads directly to lower energy consumption thanks to its high energy efficiency and has up to lower 16% refrigerant charge
- › Reduced energy consumption thanks to specially developed DC fan motor
- › The air is comfortably spread up- and downwards thanks to 5 different discharge angles that can be programmed via the remote control
- › Maintenance operations can be performed easily from the front of the unit
- › Flexible to install as the largest casing only weighs 17kg and piping connection can be done at the bottom, left or right of the unit



Efficiency data		FAA + RZAG	71A + 71MV1	100A + 100MV1	71A + 71MY1	100A + 100MY1		
Cooling capacity	Nom.	kW	6.80	9.50	6.80	9.50		
Heating capacity	Nom.	kW	7.50	10.8	7.50	10.8		
Seasonal efficiency (according to EN14825)	Cooling	Energy efficiency class	A++					
		Pdesign	kW	6.80	9.50	6.80	9.50	
		SEER		6.58	6.42	6.58	6.42	
	Heating (Average climate)	Annual energy consumption	kWh	362	518	362	518	
		Energy efficiency class		A+				
		Pdesign	kW	4.70	7.80	4.70	7.80	
	SCOP/A		4.02	4.01	4.02	4.01		
	Annual energy consumption	kWh	1,637	2,723	1,637	2,723		
Indoor unit		FAA	71A	100A	71A	100A		
Dimensions	Unit	HeightxWidthxDepth	mm	290x1,050x238	340x1,200x240	290x1,050x238	340x1,200x240	
Weight	Unit		kg	13.0	17.0	13.0	17.0	
Air filter	Type							
Fan	Air flow rate	Cooling	Low/Medium/High	m ³ /min	14.0/16/18.0	19.0/23/26.0	14.0/16/18.0	19.0/23/26.0
		Heating	Low/Medium/High	m ³ /min	14.0/16.0/18.0	19.0/23.0/26.0	14.0/16.0/18.0	19.0/23.0/26.0
Sound power level	Cooling			dBA	61	65	61	65
	Heating			dBA	61	65	61	65
Sound pressure level	Cooling	Low/High		dBA	40/45	41/49	40/45	41/49
	Heating	Low/High		dBA	40/45	41/49	40/45	41/49
Control systems	Infrared remote control				BRC7EB518			
	Wired remote control				BRC1H51 / BRC1E53A / BRC1E53B / BRC1E53C / BRC1D52			
Power supply	Phase/Frequency/Voltage			Hz/V	1~/50/220-240			
Outdoor unit		RZAG	71MV1	100MV1	71MY1	100MY1		
Dimensions	Unit	HeightxWidthxDepth	mm	990x940x320	1,430x940x320	990x940x320	1,430x940x320	
Weight	Unit		kg	70	92	70	92	
Sound power level	Cooling			dBA	64	66	65	66
Sound pressure level	Cooling	Nom.		dBA	46	47	46	47
	Heating	Nom.		dBA	49	51	49	51
Operation range	Cooling	Ambient	Min.~Max.	°CDB	-20~-52			
	Heating	Ambient	Min.~Max.	°CWB	-20~-18			
Refrigerant	Type/GWP				R-32/675			
	Charge			kg/TCO ₂ Eq	2.95/1.99	3.75/2.53	2.95/1.99	3.75/2.53
Piping connections	Liquid/Gas			mm	9.52/15.9			
	Piping length	OU - IU	Max.	m	55	85	55	85
		System	Equivalent	m	75	100	75	100
		Chargeless		m	40			
		Additional refrigerant charge		kg/m	See installation manual			
	Level difference	IU - OU	Max.	m	30.0			
Power supply	Phase/Frequency/Voltage			Hz/V	1~/50/220-240		3~/50/380-415	
Current - 50Hz	Maximum fuse amps (MFA)			A	20	32	16	

(1) EER/COP according to Eurovent 2012, for use outside EU only

(2) MFA is used to select the circuit breaker and the ground fault circuit interrupter (earth leakage circuit breaker). For more detailed information on each combination, please refer to the electrical data drawing.

Wall mounted unit

For rooms with no false ceilings nor free floor space

- › Combination with Sky Air Advance-series ensures good value for money for all types of commercial applications
- › Flat, stylish front panel blends easily within any interior décor and is easier to clean
- › Can easily be installed in both new and refurbishment projects
- › Unified indoor unit range for R-32 and R-410A
- › Combining with R-32 Bluevolution technology, reduces environmental impact with 68% compared to R-410A, leads directly to lower energy consumption thanks to its high energy efficiency and has up to lower 16% refrigerant charge



Indoor units

Efficiency data		FAA + RZASG		71A + 71MV1		100A + 100MV1		100A + 100MY1	
Cooling capacity	Nom.	kW		6.80				9.50	
Heating capacity	Nom.	kW		7.50				10.8	
Seasonal efficiency (according to EN14825)	Cooling	Energy efficiency class		A++				A+	
		Pdesign		kW		6.80		9.50	
		SEER		6.41				5.83	
		Annual energy consumption		kWh		371		570	
		Heating (Average climate)		Energy efficiency class		A			
		Pdesign		kW		4.50		6.00	
		SCOP/A		3.90				3.85	
		Annual energy consumption		kWh		1,615		2,182	
Indoor unit		FAA		71A		100A		100A	
Dimensions	Unit	HeightxWidthxDepth		mm		290x1,050x238		340x1,200x240	
Weight	Unit	kg		13.0				17.0	
Air filter	Type								
Fan	Air flow rate	Cooling	Low/Medium/High	m ³ /min	14.0/16/18.0		19.0/23/26.0		
		Heating	Low/Medium/High	m ³ /min	14.0/16.0/18.0		19.0/23.0/26.0		
Sound power level	Cooling			dBA	61		65		
	Heating			dBA	61		65		
Sound pressure level	Cooling	Low/High			dBA	40/45		41/49	
	Heating	Low/High			dBA	40/45		41/49	
Control systems	Infrared remote control						BRC7EB518		
	Wired remote control						BRC1H51 / BRC1E53A / BRC1E53B / BRC1E53C / BRC1D52		
Power supply	Phase/Frequency/Voltage						1~/50/220-240		
Outdoor unit		RZASG		71MV1		100MV1		100MY1	
Dimensions	Unit	HeightxWidthxDepth		mm		770x900x320		990x940x320	
Weight	Unit	kg		60				70	
Sound power level	Cooling			dBA	65		70		
Sound pressure level	Cooling	Nom.			dBA	46		53	
	Heating	Nom.			dBA	47		57	
Operation range	Cooling	Ambient	Min.~Max.	°CDB			-15~-46		
	Heating	Ambient	Min.~Max.	°CWB			-15~-15,5		
Refrigerant	Type/GWP						R-32/675		
	Charge		kg/TCO2Eq		2.45/1.65		2.60/1.76		
Piping connections	Liquid/Gas		mm				9.52/15.9		
	Piping length	OU - IU	Max.	m			50		
		System	Equivalent	m			70		
			Chargeless	m				30	
	Additional refrigerant charge		kg/m				See installation manual		
Level difference		IU - OU	Max.	m			30.0		
Power supply	Phase/Frequency/Voltage						1~/50/220-240		
Current - 50Hz	Maximum fuse amps (MFA)		A		20		25		
								16	

(1) EER/COP according to Eurovent 2012, for use outside EU only

(2) MFA is used to select the circuit breaker and the ground fault circuit interrupter (earth leakage circuit breaker). For more detailed information on each combination, please refer to the electrical data drawing.

Wall mounted unit

For rooms with no false ceilings nor free floor space

- › Ideal solution for small businesses and shops
- › Flat, stylish front panel blends easily within any interior décor and is easier to clean
- › Can easily be installed in both new and refurbishment projects
- › Unified indoor unit range for R-32 and R-410A
- › Combining with R-32 Bluevolution technology, reduces environmental impact with 68% compared to R-410A, leads directly to lower energy consumption thanks to its high energy efficiency and has up to lower 16% refrigerant charge



Efficiency data		FAA + AZAS		71A + 71MV1	100A + 100MV1	100A + 100MY1	
Cooling capacity	Nom.	kW		6.80		9.50	
Heating capacity	Nom.	kW		7.50		10.8	
Seasonal efficiency (according to EN14825)	Cooling	Energy efficiency class		A+		A	
		Pdesign	kW	6.80		9.50	
		SEER		5.77		5.25	
	Heating (Average climate)	Annual energy consumption		kWh	412		633
		Energy efficiency class				A	
		Pdesign	kW	4.50		6.00	
SCOP/A				3.81			
Annual energy consumption		kWh		1,654		2,205	
Indoor unit		FAA		71A	100A	100A	
Dimensions	Unit	HeightxWidthxDepth		mm	290x1,050x238	340x1,200x240	
Weight	Unit	kg			13.0	17.0	
Air filter	Type						
Fan	Air flow rate	Cooling	Low/Medium/High	m ³ /min	14.0/16/18.0	19.0/23/26.0	
		Heating	Low/Medium/High	m ³ /min	14.0/16.0/18.0	19.0/23.0/26.0	
Sound power level	Cooling			dBA	61	65	
	Heating			dBA	61	65	
Sound pressure level	Cooling	Low/High			dBA	40/45	41/49
	Heating	Low/High			dBA	40/45	41/49
Control systems	Infrared remote control		BRC7EB518				
	Wired remote control		BRC1H51 / BRC1E53A / BRC1E53B / BRC1E53C / BRC1D52				
Power supply	Phase/Frequency/Voltage		Hz/V	1~/50/220-240			
Outdoor unit		AZAS		71MV1	100MV1	100MY1	
Dimensions	Unit	HeightxWidthxDepth		mm	770x900x320	990x940x320	
Weight	Unit	kg			60	70	
Sound power level	Cooling			dBA	65	70	
Sound pressure level	Cooling	Nom.			dBA	46	53
	Heating	Nom.			dBA	47	57
Operation range	Cooling	Ambient	Min.~Max.	°CDB	-5~46		
	Heating	Ambient	Min.~Max.	°CWB	-15~-15,5		
Refrigerant	Type/GWP		R-32/675				
	Charge			kg/TCO2Eq	2.45/1.65	2.60/1.76	
Piping connections	Liquid/Gas				mm	9.52/15.9	
	Piping length	OU - IU	Max.	m	30		
		System	Equivalent	m	50		
	Chargeless				m	30	
	Additional refrigerant charge				kg/m	See installation manual	
	Level difference	IU - OU	Max.			m	30.0
Power supply	Phase/Frequency/Voltage		Hz/V	1~/50/220-240		3~/50/380-415	
Current - 50Hz	Maximum fuse amps (MFA)		A	20	25	16	

(1) EER/COP according to Eurovent 2012, for use outside EU only

(2) MFA is used to select the circuit breaker and the ground fault circuit interrupter (earth leakage circuit breaker). For more detailed information on each combination, please refer to the electrical data drawing.



Ceiling suspended unit

For wide rooms with no false ceilings nor free floor space

- › Combination with Sky Air Alpha-series ensures best in class quality, highest efficiency and performance
- › Ideal for comfortable air flow in wide rooms thanks to Coanda effect: up to 100° discharge angle

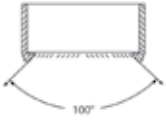

- › Even rooms with ceilings up to 3.8m can be heated up or cooled down very easily without capacity loss
- › Can easily be installed in both new and refurbishment projects
- › Unified indoor unit range for R-32 and R-410A
- › Combining with R-32 Bluevolution technology, reduces environmental impact with 68% compared to R-410A, leads directly to lower energy consumption thanks to its high energy efficiency and has up to lower 16% refrigerant charge
- › Can easily be mounted in corners and narrow spaces, as it only needs 30mm lateral service space

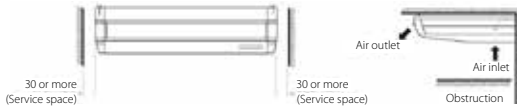

- › Reduced energy consumption thanks to specially developed small tube heat exchanger, DC fan motor and drain pump
- › 5 different fan speeds available for maximum comfort
- › Stylish unit blends easily with any interior. The flaps close entirely when the unit is not operating and there are no air intake grilles visible

Efficiency data		FHA + RZAG		71A + 71MV1	100A + 100MV1	125A + 125MV1	140A + 140MV1	71A + 71MY1	100A + 100MY1	125A + 125MY1	140A + 140MY1	
Cooling capacity	Nom.	kW		6.80	9.50	12.1	13.4	6.80	9.50	12.1	13.4	
Heating capacity	Nom.	kW		7.50	10.8	13.5	15.5	7.50	10.8	13.5	15.5	
Seasonal efficiency (according to EN14825)	Cooling	Energy efficiency class		A++				A++				
		Pdesign	kW	6.80	9.50	12.1	13.4	6.80	9.50	12.1	13.4	
		SEER		7.11	6.42	8.22	6.42	7.11	6.42	8.22	6.42	
	Heating (Average climate)	Annual energy consumption	kWh	335	518	883	1,252	335	518	883	1,252	
		Energy efficiency class		A+	A++	-		A+	A++	-		
		Pdesign	kW	4.70	7.80	9.52		4.70	7.80	9.52		
SCOP/A		4.32	4.61	4.09	4.30	4.32	4.61	4.09	4.30			
Annual energy consumption	kWh	1,523	2,369	3,259	3,100	1,523	2,369	3,259	3,100			
Indoor unit		FHA		71A	100A	125A	140A	71A	100A	125A	140A	
Dimensions	Unit	HeightxWidthxDepth	mm	235x1,270x690		235x1,590x690		235x1,270x690		235x1,590x690		
Weight	Unit		kg	32.0		38.0		32.0		38.0		
Air filter	Type			Resin net								
Fan	Air flow rate	Cooling	Low/Medium/High	m ³ /min	14.0/17.0/20.5	20.0/24.0/28.0	23.0/27.0/31.0	24.0/29.0/34.0	14.0/17.0/20.5	20.0/24.0/28.0	23.0/27.0/31.0	24.0/29.0/34.0
		Heating	Low/Medium/High	m ³ /min	14.0/17.0/20.5	20.0/24.0/28.0	23.0/27.0/31.0	24.0/29.0/34.0	14.0/17.0/20.5	20.0/24.0/28.0	23.0/27.0/31.0	24.0/29.0/34.0
Sound power level	Cooling			dBA	55	60	62	64	55	60	62	64
Sound pressure level	Cooling	Low/High		dBA	34/38	34/42	37/44	38/46	34/38	34/42	37/44	38/46
	Heating	Nom./High		dBA	36/38	38/42	41/44	42/46	36/38	38/42	41/44	42/46
Control systems	Infrared remote control			BRC7GA53 / BRC7GA56								
	Wired remote control			BRC1H51 / BRC1E53A / BRC1E53B / BRC1E53C / BRC1D52								
Power supply	Phase/Frequency/Voltage			1~/50/220-240								
Outdoor unit		RZAG		71MV1	100MV1	125MV1	140MV1	71MY1	100MY1	125MY1	140MY1	
Dimensions	Unit	HeightxWidthxDepth	mm	990x940x320		1,430x940x320		990x940x320		1,430x940x320		
Weight	Unit		kg	70		92		70		92		
Sound power level	Cooling			dBA	64	66	69	70	65	66	69	70
Sound pressure level	Cooling	Nom.		dBA	46	47	50	51	46	47	50	51
	Heating	Nom.		dBA	49	51	52		49	51	52	
Operation range	Cooling	Ambient	Min.~Max.	°CDB	-20~52							
	Heating	Ambient	Min.~Max.	°CWB	-20~18							
Refrigerant	Type/GWP			R-32/675								
	Charge			kg/TCO2Eq	2.95/1.99	3.75/2.53		2.95/1.99	3.75/2.53			
Piping connections	Liquid/Gas			mm	9.52/15.9							
Piping length	OU - IU	Max.		m	55	85		55	85			
		System	Equivalent	m	75	100		75	100			
	Chargeless			m	40							
		Additional refrigerant charge			kg/m	See installation manual						
	Level difference	IU - OU	Max.	m	30.0							
Power supply	Phase/Frequency/Voltage			Hz/V	1~/50/220-240				3~/50/380-415			
Current - 50Hz	Maximum fuse amps (MFA)			A	20	32		16				

(1) EER/COP according to Eurovent 2012, for use outside EU only

(2) MFA is used to select the circuit breaker and the ground fault circuit interrupter (earth leakage circuit breaker). For more detailed information on each combination, please refer to the electrical data drawing.

Ceiling suspended unit

For wide rooms with no false ceilings nor free floor space

- › Combination with Sky Air Advance-series ensures good value for money for all types of commercial applications
- › Ideal for comfortable air flow in wide rooms thanks to Coanda effect: up to 100° discharge angle
- › Even rooms with ceilings up to 3.8m can be heated up or cooled down very easily without capacity loss
- › Can easily be installed in both new and refurbishment projects
- › Unified indoor unit range for R-32 and R-410A
- › Combining with R-32 Bluevolution technology, reduces environmental impact with 68% compared to R-410A, leads directly to lower energy consumption thanks to its high energy efficiency and has up to lower 16% refrigerant charge



Indoor units

Efficiency data		FHA + RZASG		71A + 71MV1	100A + 100MV1	125A + 125MV1	140A + 140MV1	100A + 100MY1	125A + 125MY1	140A + 140MY1		
Cooling capacity	Nom.	kW		6.80	9.50	12.1	13.4	9.50	12.1	13.4		
Heating capacity	Nom.	kW		7.50	10.8	13.5	15.5	10.8	13.5	15.5		
Seasonal efficiency (according to EN14825)	Cooling	Energy efficiency class		A+			-			A+		
		Pdesign	kW	6.80	9.50	12.1	13.4	9.50	12.1	13.4		
		SEER		5.95	5.83	5.83	5.88	5.83	5.83	5.88		
	Annual energy consumption		kWh	400	570	1,297	1,368	570	1,297	1,368		
	Heating (Average climate)	Energy efficiency class		A			-			A		
		Pdesign	kW	4.50	6.00		7.80		6.00		7.80	
SCOP/A			3.90	3.91	3.83	3.81	3.91	3.83	3.81			
Annual energy consumption		kWh	1,616	2,148	2,193	2,866	2,148	2,193	2,866			
Indoor unit		FHA		71A	100A	125A	140A	100A	125A	140A		
Dimensions	Unit	HeightxWidthxDPTH		235x1,270x690			235x1,590x690					
Weight	Unit	kg		32.0			38.0					
Air filter	Type	Resin net										
Fan	Air flow rate	Cooling	Low/Medium/High	m³/min	14.0/17.0/20.5	20.0/24.0/28.0	23.0/27.0/31.0	24.0/29.0/34.0	20.0/24.0/28.0	23.0/27.0/31.0	24.0/29.0/34.0	
		Heating	Low/Medium/High	m³/min	14.0/17.0/20.5	20.0/24.0/28.0	23.0/27.0/31.0	24.0/29.0/34.0	20.0/24.0/28.0	23.0/27.0/31.0	24.0/29.0/34.0	
Sound power level	Cooling			dBA	55	60	62	64	60	62	64	
Sound pressure level	Cooling	Low/High			dBA	34/38	34/42	37/44	38/46	34/42	37/44	38/46
	Heating	Nom./High			dBA	36/38	38/42	41/44	42/46	38/42	41/44	42/46
Control systems	Infrared remote control		BRC7GA53 / BRC7GA56									
	Wired remote control		BRC1H51 / BRC1E53A / BRC1E53B / BRC1E53C / BRC1D52									
Power supply	Phase/Frequency/Voltage		Hz/V		1~/50/220-240							
Outdoor unit		RZASG		71MV1	100MV1	125MV1	140MV1	100MY1	125MY1	140MY1		
Dimensions	Unit	HeightxWidthxDPTH		770x900x320			990x940x320					
Weight	Unit	kg		60			70		70		77	
Sound power level	Cooling			dBA	65	70	71	73	70	71	73	
Sound pressure level	Cooling	Nom.			dBA	46	53	54	53	53	54	
	Heating	Nom.			dBA	47	57					
Operation range	Cooling	Ambient	Min.~Max.	°CDB	-15~46							
	Heating	Ambient	Min.~Max.	°CWB	-15~15.5							
Refrigerant	Type/GWP		R-32/675									
	Charge		kg/TCO2Eq	2.45/1.65	2.60/1.76		2.90/1.96		2.60/1.76		2.90/1.96	
Piping connections	Liquid/Gas		mm		9.52/15.9							
	Piping length	OU - IU	Max.	m	50							
		System	Equivalent	m	70							
	Chargeless		m		30							
	Additional refrigerant charge		kg/m		See installation manual							
Power supply	Level difference		IU - OU	Max.	m							
	Phase/Frequency/Voltage		Hz/V		1~/50/220-240				3~/50/380-415			
Current - 50Hz	Maximum fuse amps (MFA)		A	20	25	32	16					

(1) EER/COP according to Eurovent 2012, for use outside EU only

(2) MFA is used to select the circuit breaker and the ground fault circuit interrupter (earth leakage circuit breaker). For more detailed information on each combination, please refer to the electrical data drawing.

Ceiling suspended unit

For wide rooms with no false ceilings nor free floor space

- › Combination with split outdoor units is ideal for small retail, offices or residential applications
- › Ideal for comfortable air flow in wide rooms thanks to Coanda effect: up to 100° discharge angle
- › Even rooms with ceilings up to 3.8m can be heated up or cooled down very easily without capacity loss
- › Can easily be installed in both new and refurbishment projects
- › Unified indoor unit range for R-32 and R-410A
- › Combining with R-32 Bluevolution technology, reduces environmental impact with 68% compared to R-410A, leads directly to lower energy consumption thanks to its high energy efficiency and has up to lower 16% refrigerant charge



Efficiency data		FHA + RXM		35A + 35M9		50A + 50M9		60A + 60M9			
Cooling capacity	Nom.	kW		3.40		5.00		5.70			
Heating capacity	Nom.	kW		4.00		6.00		7.20			
Power input	Cooling	Nom.	kW	0.91		1.56		1.73			
	Heating	Nom.	kW	0.98		1.79		2.17			
Seasonal efficiency (according to EN14825)	Cooling	Energy efficiency class		A++		A+					
		Pdesign		kW		3.40		5.00		5.70	
		SEER		kW		6.24		5.92		6.08	
	Annual energy consumption		kWh		191		295		328		
	Heating (Average climate)	Energy efficiency class		A+		A					
		Pdesign		kW		3.10		4.35		4.71	
SCOP/A		kW		4.43		3.86		3.87			
Annual energy consumption		kWh		979		1,578		1,704			
Indoor unit		FHA		35A		50A		60A			
Dimensions	Unit	HeightxWidthxDepth		mm		235x960x690		235x1,270x690			
Weight	Unit	kg		24.0		25.0		31.0			
Air filter	Type	Resin net									
Fan	Air flow rate	Cooling	Low/Medium/High	m ³ /min	10.0/11.5/14.0		10.0/12.0/15.0		11.5/15.0/19.5		
		Heating	Low/Medium/High	m ³ /min	10.0/11.5/14.0		10.0/12.0/15.0		11.5/15.0/19.5		
Sound power level	Cooling	dBA		53		54					
Sound pressure level	Cooling	Low/High		dBA		31/36		33/37			
	Heating	Nom./High		dBA		34/36		35/37			
Control systems	Infrared remote control				BRC7GA53 / BRC7GA56						
	Wired remote control				BRC1H51 / BRC1E53A / BRC1E53B / BRC1E53C / BRC1D52						
Power supply	Phase/Frequency/Voltage		Hz/V		1~/50/220-240						
Outdoor unit		RXM		35M9		50M9		60M9			
Dimensions	Unit	HeightxWidthxDepth		mm		550x765x285		735x825x300			
Weight	Unit	kg		32		47					
Sound power level	Cooling	dBA		61		62		63			
	Heating	dBA		61		62		63			
Operation range	Cooling	Ambient	Min.~Max.	°CDB		-10~46					
	Heating	Ambient	Min.~Max.	°CWB		-15~18					
Refrigerant	Type		R-32								
	GWP		675.0								
	Charge		kg/TCO2Eq		0.76/0.52		1.40/0.95		1.45/0.98		
Piping connections	Liquid	OD	mm		6,35		6,4				
	Gas	OD	mm		9.50		12.7				
	Piping length		OU - IU	Max.	m		20.0		30		
	Additional refrigerant charge		kg/m		0.02 (for piping length exceeding 10m)						
	Level difference		IU - OU	Max.	m		20.0				
Power supply	Phase/Frequency/Voltage		Hz/V		1~/50/220-240						
Current - 50Hz	Maximum fuse amps (MFA)		A		10		15				

(1) EER/COP according to Eurovent 2012, for use outside EU only

(2) MFA is used to select the circuit breaker and the ground fault circuit interrupter (earth leakage circuit breaker). For more detailed information on each combination, please refer to the electrical data drawing.

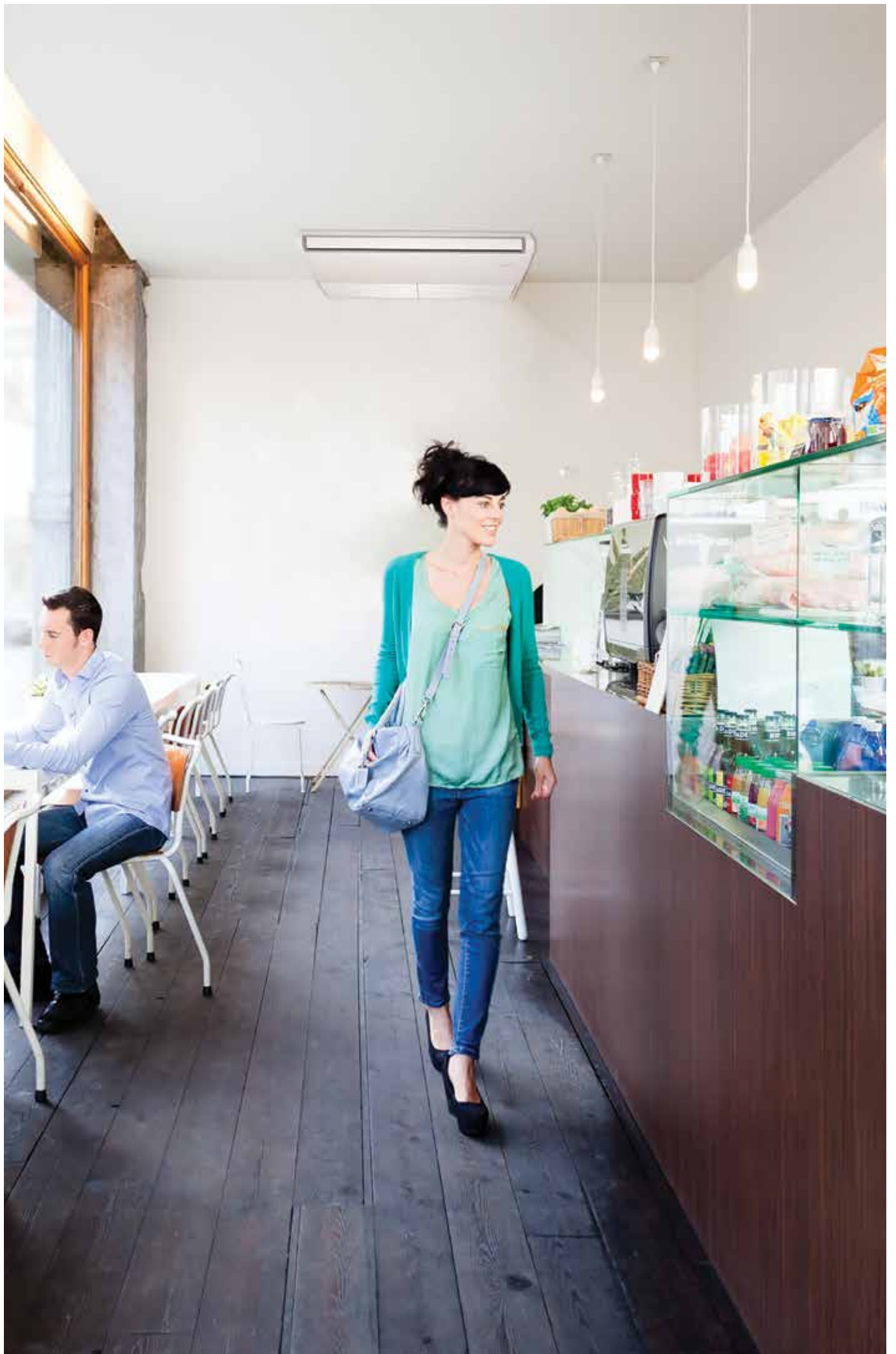



4-way blow ceiling suspended unit

Unique Daikin unit for high rooms with no false ceilings nor free floor space

- › Combination with Sky Air Alpha-series ensures best in class quality, highest efficiency and performance
- › Even rooms with ceilings up to 3.5m can be heated up or cooled down very easily without capacity loss
- › Can easily be installed in both new and refurbishment projects
- › Unified indoor unit range for R-32 and R-410A
- › Combining with R-32 Bluevolution technology, reduces environmental impact with 68% compared to R-410A, leads directly to lower energy consumption thanks to its high energy efficiency and has up to lower 16% refrigerant charge
- › Individual flap control: flexibility to suit every room layout without changing the location of the unit!
- › Stylish modern casing finished in pure white (RAL9010) and iron grey (RAL7011) blends easily with any interior
- › Optimum comfort guaranteed with automatic air flow adjustment to the required load
- › 5 different discharge angles between 0 and 60° can be programmed via the remote control

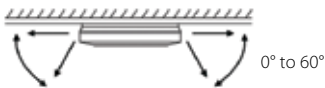

- › Standard drain pump with 500mm lift increases flexibility and installation speed

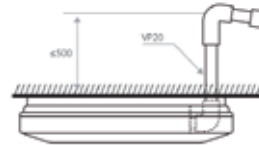

Efficiency data			FUA + RZAG	71A + 71MV1	100A + 100MV1	125A + 125MV1	71A + 71MY1	100A + 100MY1	125A + 125MY1	
Cooling capacity	Nom.		kW	6.80	9.50	12.1	6.80	9.50	12.1	
Heating capacity	Nom.		kW	7.50	10.8	13.5	7.50	10.8	13.5	
Seasonal efficiency (according to EN14825)	Cooling	Energy efficiency class		A++		-	A++		-	
		Pdesign	kW	6.80	9.50	12.1	6.80	9.50	12.1	
		SEER		7.02	6.42	6.39	7.02	6.42	6.39	
	Heating (Average climate)	Annual energy consumption	kWh	339	518	1,136	339	518	1,136	
		Energy efficiency class		A+		-	A+		-	
		Pdesign	kW	4.70	7.80	9.52	4.70	7.80	9.52	
SCOP/A		4.20	4.50	4.26	4.20	4.50	4.26			
Annual energy consumption	kWh	1,567	2,427	3,129	1,567	2,427	3,129			
Indoor unit			FUA	71A	100A	125A	71A	100A	125A	
Dimensions	Unit	HeightxWidthxDepth	mm	198x950x950						
Weight	Unit		kg	25.0	26.0		25.0	26.0		
Air filter	Type			Resin net						
Fan	Air flow rate	Cooling	Low/Medium/High	m ³ /min	16.0/19.5/23.0	20.0/25.5/31.0	20.5/26.5/32.5	16.0/19.5/23.0	20.0/25.5/31.0	20.5/26.5/32.5
		Heating	Low/Medium/High	m ³ /min	16.0/19.5/23.0	20.0/25.5/31.0	20.5/26.5/32.5	16.0/19.5/23.0	20.0/25.5/31.0	20.5/26.5/32.5
Sound power level	Cooling			dBA	59	64	65	59	64	65
	Heating			dBA	59	64	65	59	64	65
Sound pressure level	Cooling	Low/High		dBA	35/41	39/46	40/47	35/41	39/46	40/47
	Heating	Low/High		dBA	35/41	39/46	40/47	35/41	39/46	40/47
Control systems	Infrared remote control			BRC7EB518						
	Wired remote control			BRC1H51 / BRC1E53A / BRC1E53B / BRC1E53C / BRC1D52						
Power supply	Phase/Frequency/Voltage		Hz/V	-/-/-						
Outdoor unit			RZAG	71MV1	100MV1	125MV1	71MY1	100MY1	125MY1	
Dimensions	Unit	HeightxWidthxDepth	mm	990x940x320	1,430x940x320		990x940x320	1,430x940x320		
Weight	Unit		kg	70	92		70	92		
Sound power level	Cooling			dBA	64	66	69	65	66	69
Sound pressure level	Cooling	Nom.		dBA	46	47	50	46	47	50
	Heating	Nom.		dBA	49	51	52	49	51	52
Operation range	Cooling	Ambient	Min.~Max.	°CDB	-20~-52					
	Heating	Ambient	Min.~Max.	°CWB	-20~-18.0					
Refrigerant	Type/GWP			R-32/675						
	Charge		kg/TCO2Eq	2.95/1.99	3.75/2.53		2.95/1.99	3.75/2.53		
Piping connections	Liquid/Gas		mm	9.52/15.9						
	Piping length	OU - IU	Max.	m	55	85		55	85	
		System	Equivalent	m	75	100		75	100	
	Chargeless			m	40					
	Additional refrigerant charge		kg/m	See installation manual						
Power supply	Level difference IU - OU		Max.	m	30.0					
	Phase/Frequency/Voltage		Hz/V	1~/50/220-240				3~/50/380-415		
Current - 50Hz	Maximum fuse amps (MFA)		A	20	32		16			

(1) EER/COP according to Eurovent 2012, for use outside EU only

(2) MFA is used to select the circuit breaker and the ground fault circuit interrupter (earth leakage circuit breaker). For more detailed information on each combination, please refer to the electrical data drawing.



4-way blow ceiling suspended unit

Unique Daikin unit for high rooms with no false ceilings nor free floor space

- › Combination with Sky Air Advance-series ensures good value for money for all types of commercial applications
- › Even rooms with ceilings up to 3.5m can be heated up or cooled down very easily without capacity loss
- › Can easily be installed in both new and refurbishment projects
- › Unified indoor unit range for R-32 and R-410A
- › Combining with R-32 Bluevolution technology, reduces environmental impact with 68% compared to R-410A, leads directly to lower energy consumption thanks to its high energy efficiency and has up to lower 16% refrigerant charge
- › Individual flap control: flexibility to suit every room layout without changing the location of the unit!
- › Stylish modern casing finished in pure white (RAL9010) and iron grey (RAL7011) blends easily with any interior



Indoor units

Efficiency data			FUA + RZASG	71A + 71MV1	100A + 100MV1	125A + 125MV1	100A + 100MY1	125A + 125MY1	
Cooling capacity	Nom.		kW	6.80	9.50	12.1	9.50	12.1	
Heating capacity	Nom.		kW	7.50	10.8	13.5	10.8	13.5	
Seasonal efficiency (according to EN14825)	Cooling	Energy efficiency class		A++	A+	-	A+	-	
		Pdesign	kW	6.80	9.50	12.1	9.50	12.1	
		SEER		6.16	5.83	5.49	5.83	5.49	
	Heating (Average climate)	Annual energy consumption	kWh	386	570	1,378	570	1,378	
		Energy efficiency class		A	A+	-	A+	-	
		Pdesign	kW	4.50		6.00			
SCOP/A		3.90	4.01	3.84	4.01	3.84			
Annual energy consumption	kWh	1,615	2,095	2,188	2,095	2,188			
Indoor unit			FUA	71A	100A	125A	100A	125A	
Dimensions	Unit	HeightxWidthxDepth	mm	198x950x950					
Weight	Unit		kg	25.0				26.0	
Air filter	Type			Resin net					
Fan	Air flow rate	Cooling	Low/Medium/High	m ³ /min	16.0/19.5/23.0	20.0/25.5/31.0	20.5/26.5/32.5	20.0/25.5/31.0	20.5/26.5/32.5
		Heating	Low/Medium/High	m ³ /min	16.0/19.5/23.0	20.0/25.5/31.0	20.5/26.5/32.5	20.0/25.5/31.0	20.5/26.5/32.5
Sound power level	Cooling			dBA	59	64	65	64	65
	Heating			dBA	59	64	65	64	65
Sound pressure level	Cooling	Low/High		dBA	35/41	39/46	40/47	39/46	40/47
	Heating	Low/High		dBA	35/41	39/46	40/47	39/46	40/47
Control systems	Infrared remote control			BRC7EB518					
	Wired remote control			BRC1H51 / BRC1E53A / BRC1E53B / BRC1E53C / BRC1D52					
Power supply	Phase/Frequency/Voltage		Hz/V	-/-/-					
Outdoor unit			RZASG	71MV1	100MV1	125MV1	100MY1	125MY1	
Dimensions	Unit	HeightxWidthxDepth	mm	770x900x320	990x940x320				
Weight	Unit		kg	60				70	
Sound power level	Cooling			dBA	65	70	71	70	
Sound pressure level	Cooling	Nom.		dBA	46	53			
	Heating	Nom.		dBA	47	57			
Operation range	Cooling	Ambient	Min.~Max.	°CDB	-15~46				
	Heating	Ambient	Min.~Max.	°CWB	-15~-15.5				
Refrigerant	Type/GWP			R-32/675					
	Charge		kg/TCO2Eq	2.45/1.65	2.60/1.76				
Piping connections	Liquid/Gas		mm	9.52/15.9					
	Piping length	OU - IU	Max.	m	50				
		System	Equivalent	m	70				
			Chargeless	m	30				
	Additional refrigerant charge		kg/m	See installation manual					
Power supply	Phase/Frequency/Voltage		Hz/V	1~/50/220-240			3~/50/380-415		
Current - 50Hz	Maximum fuse amps (MFA)		A	20	25	32	16		

(1) EER/COP according to Eurovent 2012, for use outside EU only

(2) MFA is used to select the circuit breaker and the ground fault circuit interrupter (earth leakage circuit breaker). For more detailed information on each combination, please refer to the electrical data drawing.

Floor standing unit

For commercial spaces with high ceilings

Combination with Sky Air Alpha-series ensures best in class quality, highest efficiency and performance

- › Unified indoor unit range for R-32 and R-410A
- › Ideal solution for commercial and busy environments
- › Decrease of temperature variation by automatic fan speed selection or freely selectable 3-step fan speed.
- › Improved comfort as a result of better airflow distribution from the vertical out blow which allows manual adjustment of air outlet blades at the top of the unit.
- › Selectable horizontal out blow to better suit the layout of the room (via wired remote controller BRC1E*)
- › No optional adapter needed for DIII-connection, link your unit into the wider building management system.

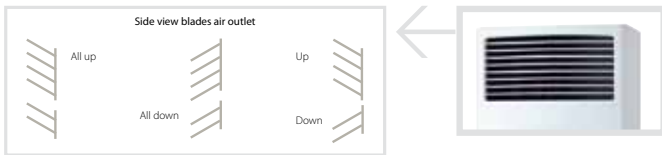

Efficiency data		FVA + RZAG	71A + 71MV1	100A + 100MV1	125A + 125MV1	140A + 140MV1	71A + 71MY1	100A + 100MY1	125A + 125MY1	140A + 140MY1	
Cooling capacity	Nom.	kW	6.80	9.50	12.1	13.4	6.80	9.50	12.1	13.4	
Heating capacity	Nom.	kW	7.50	10.8	13.5	15.5	7.50	10.8	13.5	15.5	
Seasonal efficiency (according to EN14825)	Cooling	Energy efficiency class	A++	A+	-	-	A++	A+	-	-	
		Pdesign	kW	6.80	9.50	12.1	13.4	6.80	9.50	12.1	13.4
		SEER		6.37	6.00	6.41	6.12	6.37	6.00	6.41	6.12
	Heating (Average climate)	Annual energy consumption	kWh	374	554	1133	1314	374	554	1133	1314
		Energy efficiency class		A+	-	-	-	A+	-	-	-
		Pdesign	kW	4.70	7.80	9.52	9.52	4.70	7.80	9.52	9.52
	SCOP/A		4.05	4.20	4.15	3.94	4.05	4.20	4.15	3.94	
	Annual energy consumption	kWh	1625	2600	3209	3383	1625	2600	3209	3383	

Indoor unit		FVA	71A	100A	125A	140A	71A	100A	125A	140A	
Dimensions	Unit	HeightxWidthxDepth	mm	1,850x600x270		1,850x600x350		1,850x600x270		1,850x600x350	
Weight	Unit		kg	39		47		39		47	
Air filter	Type			Resin net							
Fan - Air flow rate	Cooling	High/Low	m³/min	18/14	28/22	28/24	30/26	18/14	28/22	28/24	30/26
	Heating	High/Low	m³/min	18/14	28/22	28/24	30/26	18/14	28/22	28/24	30/26
Sound power level	Cooling		dBA	55	62	63	65	55	62	63	65
	Heating		dBA	55	62	63	65	55	62	63	65
Sound pressure level	Cooling	High/Low	dBA	43/38	50/44	51/46	53/48	43/38	50/44	51/46	53/48
	Heating	High/Low	dBA	43/38	50/44	51/46	53/48	43/38	50/44	51/46	53/48
Refrigerant	Type			R-32 / R-410A							
Control systems	Wired remote control			BRC1H51 / BRC1E53A / BRC1E53B / BRC1E53C / BRC1D52							
Power supply	Phase / Frequency / Voltage	Hz / V		1~ / 50/60 / 220-240/220							

Outdoor unit		RZAG	71MV1	100MV1	125MV1	140MV1	71MY1	100MY1	125MY1	140MY1	
Dimensions	Unit	HeightxWidthxDepth	mm	990x940x320	1,430x940x320		990x940x320		1,430x940x320		
Weight	Unit		kg	70	92		70		92		
Sound power level	Cooling		dBA	64	66	69	73	65	66	69	70
Sound pressure level	Cooling	Nom.	dBA	46	47	50	54	46	47	50	51
	Heating	Nom.	dBA	49	51	52	57	49	51		52
Operation range	Cooling	Ambient	Min.~Max.	°CDB			-20~52		-20~52		
	Heating	Ambient	Min.~Max.	°CWB			-20~18.0		-20~18.0		
Refrigerant	Type/GWP			R-32/675							
	Charge	kg/CO2Eq		2.95/1.99	3.75/2.53	2.90/1.96	2.95/1.99		3.75/2.53		
Piping connections	Liquid/Gas		mm	9.52/15.9							
	Piping length	OU - IU	Max.	m	55	85	50	55		85	
		System	Equivalent	m	75	100	70	75		100	
		Chargeless	m		40		30		40		
		Additional refrigerant charge	kg/m		See installation manual						
	Level difference	IU - OU	Max.	m	30.0						
Power supply	Phase/Frequency/Voltage	Hz/V		1~/50/220-240			3~/50/380-415				
Current - 50Hz	Maximum fuse amps (MFA)	A		20		32			16		

(1) EER/COP according to Eurovent 2012, for use outside EU only

(2) MFA is used to select the circuit breaker and the ground fault circuit interrupter (earth leakage circuit breaker). For more detailed information on each combination, please refer to the electrical data drawing.

Floor standing unit

For commercial spaces with high ceilings

Combination with Sky Air Alpha-series ensures best in class quality, highest efficiency and performance

- › Unified range for R-32 and R-410A simplifying stock
- › Ideal solution for commercial and busy environments
- › Decrease of temperature variation by automatic fan speed selection or freely selectable 3-step fan speed.
- › Improved comfort as a result of better airflow distribution from the vertical out blow which allows manual adjustment of air outlet blades at the top of the unit.
- › Selectable horizontal out blow to better suit the layout of the room (via wired remote controller BRC1E*)
- › No optional adapter needed for DIII-connection, link your unit into the wider building management system.



Indoor units

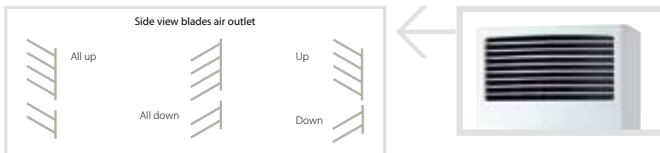

Efficiency data			FVA + RZASG	71A + 71MV1	100A + 100MV1	125A + 125MV1	140A + 140MV1	100A + 100MY1	125A + 125MY1	140A + 140MY1		
Cooling capacity	Nom.	kW	6.80	9.50	12.1	13.4	13.4	9.50	12.1	13.4		
Heating capacity	Nom.	kW	7.50	10.8	13.5	15.5	10.8	13.5	15.5	15.5		
Power input	Cooling	Nom. kW	-	-	-	-	-	-	-	-		
	Heating	Nom. kW	-	-	-	-	-	-	-	-		
Seasonal efficiency (according to EN14825)	Cooling	Energy efficiency class	A+			-			A+			
		Pdesign	kW	6.80	9.50	12.1	13.4	9.50	12.1	13.4		
		SEER		5.83	5.72	5.52	5.63	5.72	5.52	5.63		
	Heating (Average climate)	Annual energy consumption	kWh	408	581	1,370	1,428	581	1,370	1,428		
		Energy efficiency class		A+			-			A		
		Pdesign	kW	4.50	6.00	6.00	7.80	6.00	6.00	6.00	7.80	
Nominal efficiency	EER	SCOP/A	4.04	3.83	3.64	3.81	3.83	3.64	3.81	3.81		
		Annual energy consumption	kWh	2,297	2,654	2,764	-	2,654	2,764	-		
	COP	EER	3.21	3.37	2.81	3.16	3.37	2.81	3.16	3.16		
		COP	3.69	3.65	3.47	3.41	3.65	3.47	3.41			
Annual energy consumption	kWh	1,559	2,193	2,308	2,866	2,193	2,308	2,866				
Energy labeling Directive	Cooling/Heating		-	-	-	-	-	-	-			

Indoor unit			FVA	71A	100A	125A	140A	100A	125A	140A
Dimensions	Unit	HeightxWidthxDepth	mm	1,850x600x270		1,850x600x350				
Weight	Unit		kg	39	47					
Air filter	Type			Resin net						
Fan - Air flow rate	Cooling	High/Low	m³/min	18/14	28/22	28/24	30/26	28/22	28/24	30/26
	Heating	High/Low	m³/min	18/14	28/22	28/24	30/26	28/22	28/24	30/26
Sound power level	Cooling		dB(A)	55	62	63	65	62	63	65
	Heating		dB(A)	55	62	63	65	62	63	65
Sound pressure level	Cooling	High/Low	dB(A)	43/38	50/44	51/46	53/48	50/44	51/46	53/48
	Heating	High/Low	dB(A)	43/38	50/44	51/46	53/48	50/44	51/46	53/48
Refrigerant	Type			R-32 / R-410A						
Control systems	Wired remote control			BRC1H51 / BRC1E53A / BRC1E53B / BRC1E53C / BRC1D52						
Power supply	Phase / Frequency / Voltage	Hz / V		1~ / 50/60 / 220-240/220						

Outdoor unit			RZASG	71MV1	100MV1	125MV1	140MV1	100MY1	125MY1	140MY1
Dimensions	Unit	HeightxWidthxDepth	mm	770x900x320		990x940x320				
Weight	Unit		kg	60	70	71	78	70	71	77
Sound power level	Cooling		dB(A)	65	70	71	73	70	71	73
	Heating		dB(A)	65	70	71	73	70	71	73
Sound pressure level	Cooling	Nom.	dB(A)	46	53		54	53		54
	Heating	Nom.	dB(A)	47	57		57	57		57
Operation range	Cooling	Ambient	Min.~Max.	-15~46						
	Heating	Ambient	Min.~Max.	-15~15.5						
Refrigerant	Type/GWP			R-32/675						
	Charge	kg/CO2Eq		2.45/1.65	2.60/1.76		2.90/1.96	2.60/1.76		2.90/1.96
Piping connections	Liquid/Gas		mm	9.52/15.9						
	Piping length	OU - IU	Max.	50						
		System	Equivalent	70						
		Chargeless		30						
	Additional refrigerant charge	Level difference	IU - OU	Max.	See installation manual					
Power supply	Phase/Frequency/Voltage	Hz/V		1~/50/220-240				3~/50/380-415		
Current - 50Hz	Maximum fuse amps (MFA)	A		20	25	32		16	20	16

(1) EER/COP according to Eurovent 2012, for use outside EU only

(2) MFA is used to select the circuit breaker and the ground fault circuit interrupter (earth leakage circuit breaker). For more detailed information on each combination, please refer to the electrical data drawing.



Concealed floor standing unit

Designed to be concealed in walls

Combination with split outdoor units is ideal for small retail, offices or residential applications

- › Unified range for R-32 and R-410A simplifying stock
- › Ideal for installation in offices, hotels and residential applications
- › Blends unobtrusively with any interior design: only the suction and discharge grills are visible
- › Its low height (620 mm) enables the unit to fit perfectly beneath a window
- › Requires very little installation space as the depth is only 200mm
- › High ESP allows flexible installation



Indoor units

Efficiency data			FNA + RXM	25A + 25M9	35A + 35M9	50A + 50M9	60A + 60M9
Cooling capacity	Nom.		kW	2,60	3,40	5,00	6,00
Heating capacity	Nom.		kW	3,20	4,00	5,80	7,00
Power input	Cooling	Nom.	kW	0,68	1,10	1,48	2,22
	Heating	Nom.	kW	0,80	1,15	1,74	2,25
Seasonal efficiency (according to EN14825)	Cooling	Energy efficiency class		A+			
		Pdesign	kW	2,60	3,40	5,00	6,00
		SEER		5,68	5,70	5,77	5,56
	Annual energy consumption		kWh	160	209	303	378
	Heating (Average climate)	Energy efficiency class		A+			
		Pdesign	kW	2,80	2,90	4,00	4,60
SCOP/A			4,24	4,05	4,09	4,16	
Annual energy consumption		kWh	924	1002	1369	1547	
Nominal efficiency	EER			3.80	3.09	3.38	2.70
	COP			4.00	3.48	3.34	3.11
	Annual energy consumption		kWh	-	-	-	-
	Energy labeling Directive	Cooling/Heating		-	-	-	-

Indoor unit			FNA	25A	35A	50A	60A
Dimensions	Unit	HeightxWidthxDepth	mm	620 / 720(2)x750x200		620 / 720(2)x1,150x200	
Weight	Unit		kg	23		30	
Air filter	Type			Resin net			
Fan - Air flow rate	Cooling	High/Low	m ³ /min	8.7/7.3		16.0/13.5	
	Heating	High/Low	m ³ /min	8.7/7.3		16.0/13.5	
Fan - External static pressure	High/Nom./Maximum available/High		Pa	48/30/-		49/40/-	
Sound power level	Cooling		dBA	53		56	
Sound pressure level	Cooling	High/Low	dBA	33/28		36/30	
	Heating	High/Low	dBA	33/28		36/30	
Refrigerant	Type			R-32 / R-410A			
Control systems	Infrared remote control			BRC4C65			
	Wired remote control			BRC1H51 / BRC1E53A / BRC1E53B / BRC1E53C / BRC1D52			
Power supply	Phase / Frequency / Voltage		Hz / V	1 ~ / 50/60 / 220-240/220			

Outdoor unit			RXM	25M9	35M9	50M9	60M9
Dimensions	Unit	HeightxWidthxDepth	mm	550x765x285		735x825x300	
Weight	Unit		kg	32		47	
Sound power level	Cooling		dBA	59	61	62	63
	Heating		dBA	59	61	62	63
Sound pressure level	Cooling	Low/High	dBA	46/-	49/-	48/44	
	Heating	Low/High	dBA	47/-	49/-	49/45	
Operation range	Cooling	Ambient	Min.~Max.	°CDB -10~46			
	Heating	Ambient	Min.~Max.	°CWB -15~18			
Refrigerant	Type			R-32			
	GWP			675.0			
	Charge		kg/CO ₂ Eq	0.76/0.52		1.40/0.95	1.45/0.98
Piping connections	Liquid	OD	mm	6,35		6,4	
	Gas	OD	mm	9,50		12,7	
	Piping length	OU - IU Max. System Chargeless	m	20,0		30	
	Additional refrigerant charge		kg/m	0.02 (for piping length exceeding 10m)			
	Level difference		IU - OU Max.	m	20,0		
Power supply	Phase/Frequency/Voltage		Hz/V	1~/50/220-240			
Current - 50Hz	Maximum fuse amps (MFA)		A	10		15	

(1) EER/COP according to Eurovent 2012, for use outside EU only

(2) Including installation legs (3) MFA is used to select the circuit breaker and the ground fault circuit interrupter (earth leakage circuit breaker). For more detailed information on each combination, please refer to the electrical data drawing.



Sky Air, from high specification, tailored solutions to primary cooling and heating

Combinations with R-410A outdoor units

Ceiling mounted cassettes 58

FCAHG-G	R-410A	58
FCAG-A	R-410A	60
FFA-A	R-410A	64

Concealed ceiling units 65

FDXM-F3	R-410A	66
FBA-A	R-410A	67
FDA-A	R-410A	70
FDQ-B	R-410A	71
ADEQ-C	R-410A	72
ABQ-C	R-410A	73

Wall mounted units 75

FAA-A	R-410A	75
-------	---------------	----

Ceiling suspended units 77

FHA-A	R-410A	77
FUA-A	R-410A	82

Floor standing units 84

FVA-A	R-410A	84
-------	---------------	----

Concealed floor standing units 87

FNA-A	R-410A	87
-------	---------------	----





High COP, round flow cassette

360° air discharge for optimum efficiency and comfort

- › Combination with Seasonal Smart ensures best in class quality, highest efficiency and performance
- › High COP cassette ensures top performance, great savings in energy consumption and a comfortable environment for commercial applications
- › Unified indoor unit range for R-32 and R-410A
- › Automatic filter cleaning results in higher efficiency & comfort and lower maintenance costs. 2 filters available: standard filter and finer mesh filter (for fine dust applications e.g. clothing shops)
- › Two optional intelligent sensors improve energy efficiency and comfort.
- › Individual flap control: flexibility to suit every room layout without changing the location of the unit!
- › Modern style decoration panel is available in 3 different variations: white (RAL9010) with grey louvers, full white (RAL9010) or auto cleaning panel
- › 5 different fan speeds available for maximum comfort
- › Reduced energy consumption thanks to specially developed small tube heat exchanger, DC fan motor and drain pump
- › Optional fresh air intake



- › Branch duct discharge allows to optimize air distribution in irregular shaped rooms or to supply air to small adjacent rooms
- › Standard drain pump with 675mm lift increases flexibility and installation speed

Efficiency data		FCAHG + RZQG	71G + 71L9V1	100G + 100L9V1	125G + 125L9V1	140G + 140L9V1	71G + 71L8Y1	100G + 100L8Y1	125G + 125L8Y1	140G + 140LY1	
Cooling capacity	Nom.	kW	6.80	9.50	12.0	13.4	6.80	9.50	12.0	13.4	
Heating capacity	Nom.	kW	7.50	10.8	13.5	15.5	7.50	10.8	13.5	15.5	
Power input	Cooling	Nom. kW	1.66	2.15	3.00	4.00	1.66	2.15	3.00	4.00	
	Heating	Nom. kW	1.56	2.16	3.07	3.77	1.56	2.16	3.07	3.77	
Seasonal efficiency (according to EN14825)	Cooling	Energy efficiency class	A++		-		A++		-		
		Pdesign	kW	6.80	9.50	12.0	-	6.80	9.50	12.0	-
		SEER		6.91	7.00	6.61	-	6.91	7.00	6.61	-
	Heating (Average climate)	Annual energy consumption	kWh	345	475	636	-	345	475	636	-
		Energy efficiency class		A+	A++		-	A+	A++		-
		Pdesign	kW	7.60	11.30	12.66	-	7.60	11.30	12.66	-
Nominal efficiency	SCOP/A		4.54	4.80	4.63	-	4.54	4.80	4.63	-	
	Annual energy consumption	kWh	2,344	3,296	3,829	-	2,344	3,296	3,829	-	
	EER		4.09	4.42	4.00	3.35	4.09	4.42	4.00	3.35	
COP			4.80	4.99	4.40	4.12	4.80	4.99	4.40	4.12	
	Annual energy consumption	kWh	830	1,075	1,500	-	830	1,075	1,500	-	
Energy labeling Directive		Cooling/Heating	A/A		-/-		A/A		-/-		

Indoor unit			FCAHG	71G	100G	125G	140G	71G	100G	125G	140G	
Dimensions	Unit	HeightxWidthxD	mm	288x840x840								
Weight	Unit		kg	25								
Air filter	Type			Resin net								
Decoration panel	Model	BYCQ140DGF9 - auto cleaning panel with fine mesh filter / BYCQ140DG9 - auto cleaning panel / BYCQ140DW - full white / BYCQ140D - white with grey louvers										
		Colour	Pure White (RAL 9010)									
Dimensions	Unit	HeightxWidthxD	mm	130x950x950 / 130x950x950 / 50x950x950 / 50x950x950								
Weight	Unit		kg	10.3 / 10.3 / 5.4 / 5.4								
Fan	Air flow rate	Cooling	Low/Medium/High	m³/min	12.2/16.7/21.2	19.0/25.7/32.3	19.9/26.7/33.5	21.1/27.3/33.5	12.2/16.7/21.2	19.0/25.7/32.3	19.9/26.7/33.5	21.1/27.3/33.5
		Heating	Low/Medium/High	m³/min	12.2/16.7/21.2	19.0/25.7/32.3	19.9/26.7/33.5	21.1/27.3/33.5	12.2/16.7/21.2	19.0/25.7/32.3	19.9/26.7/33.5	21.1/27.3/33.5
Sound power level	Cooling		dBA	53		61		53		61		
	Heating		dBA	53		61		53		61		
Sound pressure level	Cooling	Low/High	dBA	29/36	33/44	35/45	37/45	29/36	33/44	35/45	37/45	
	Heating	Low/High	dBA	29/36	33/44	35/45	37/45	29/36	33/44	35/45	37/45	
Control systems	Infrared remote control			BRC7FA532F								
	Wired remote control			BRC1H51 / BRC1E53A / BRC1E53B / BRC1E53C / BRC1D52								
Power supply	Phase/Frequency/Voltage		Hz/V	1~/50/60/220-240/220								

Outdoor unit			RZQG	71L9V1	100L9V1	125L9V1	140L9V1	71L8Y1	100L8Y1	125L8Y1	140LY1
Dimensions	Unit	HeightxWidthxD	mm	990x940x320	1,430x940x320		990x940x320		1,430x940x320		
Weight	Unit		kg	69	95		80		101		
Sound power level	Cooling		dBA	64	66	67	69	64	66	67	69
	Heating	Nom.	dBA	48	50	51	52	48	50	51	52
Sound pressure level	Cooling	Nom.	dBA	50	52	53		50	52	53	
	Heating	Nom.	dBA	50	52	53		50	52	53	
Operation range	Cooling	Ambient	Min.~Max.	-15~50							
	Heating	Ambient	Min.~Max.	-20~-15.5							
Refrigerant	Type/GWP			R-410A/2,087.5							
	Charge		kg/CO2Eq	2.9/6.1	4.0/8.4		2.9/6.1		4.0/8.4		
Piping connections	Liquid/Gas		mm	9.52/15.9							
	Piping length	OU - IU	Max.	50	75		50		75		
	System	Equivalent	m	70	90		70		90		
	Chargeless		m	30							
	Additional refrigerant charge		kg/m	See installation manual							
Power supply	Level difference	IU - OU	Max.	30.0							
	Phase/Frequency/Voltage		Hz/V	1~/50/220-240				3N~/50/380-415			
Current - 50Hz	Maximum fuse amps (MFA)		A	25	40		16		25		

The BYCQ140D7W1W has white insulations. Be informed that formation of dirt on white insulation is visibly stronger and that it is consequently not advised to install the BYCQ140D7W1W decoration panel in environments exposed to concentrations of dirt. | BYCQ140D7W1: pure white standard panel with grey louvers; BYCQ140D7W1W: pure white standard panel with white louvers; BYCQ140D7GW1: pure white auto cleaning panel. | MFA is used to select the circuit breaker and the ground fault circuit interrupter (earth leakage circuit breaker). For more detailed information on each combination, please refer to the electrical data drawing.



High COP, round flow cassette

360° air discharge for optimum efficiency and comfort

- › Combination with Seasonal Classic ensures good value for money for all types of commercial applications
- › High COP cassette ensures top performance, great savings in energy consumption and a comfortable environment for commercial applications
- › Unified indoor unit range for R-32 and R-410A
- › Automatic filter cleaning results in higher efficiency & comfort and lower maintenance costs. 2 filters available: standard filter and finer mesh filter (for fine dust applications e.g. clothing shops)
- › Two optional intelligent sensors improve energy efficiency and comfort.
- › Individual flap control: flexibility to suit every room layout without changing the location of the unit!
- › Modern style decoration panel is available in 3 different variations: white (RAL9010) with grey louvers, full white (RAL9010) or auto cleaning panel



Indoor units

Efficiency data		FCAHG + RZQSG	71G + 71L3V1	100G + 100L9V1	125G + 125L9V1	140G + 140L9V1	100G + 100L8Y1	125G + 125L8Y1	140G + 140LY1	
Cooling capacity	Nom.	kW	6.80	9.50	12.0	13.4	9.50	12.0	13.4	
Heating capacity	Nom.	kW	7.50	10.8	13.5	15.5	10.8	13.5	15.5	
Power input	Cooling	Nom.	1.94	2.57	3.71	4.17	2.57	3.71	4.17	
	Heating	Nom.	1.83	2.51	3.60	4.29	2.51	3.60	4.29	
Seasonal efficiency (according to EN14825)	Cooling	Energy efficiency class	A++		A	-	A++	A	-	
		Pdesign	kW	6.80	9.50	12.0	-	9.50	12.0	-
		SEER		6.50	6.70	5.40	-	6.70	5.40	-
		Annual energy consumption	kWh	367	497	778	-	497	778	-
	Heating (Average climate)	Energy efficiency class	A+		-	-	A+	-	-	
		Pdesign	kW	7.60	8.03	-	-	8.03	-	-
SCOP/A			4.15	4.30	4.10	-	4.30	4.10	-	
	Annual energy consumption	kWh	2,563	2,615	2,742	-	2,615	2,742	-	
Nominal efficiency	EER		3.50	3.70	3.23	3.21	3.70	3.23	3.21	
	COP		4.10	4.30	3.75	3.61	4.30	3.75	3.61	
	Annual energy consumption	kWh	970	1,285	1,855	-	1,285	1,855	-	
	Energy labeling Directive	Cooling/Heating	A/A		-/-	-/-	A/A	-/-	-/-	

Indoor unit		FCAHG	71G	100G	125G	140G	100G	125G	140G		
Dimensions	Unit	HeightxWidthxDepth	288x840x840								
Weight	Unit		25								
Air filter	Type		Resin net								
Decoration panel	Model		BYCQ140DGF9 - auto cleaning panel with fine mesh filter / BYCQ140DG9 - auto cleaning panel / BYCQ140DW - full white / BYCQ140D - white with grey louvers								
	Colour		Pure White (RAL 9010)								
	Dimensions	HeightxWidthxDepth	130x950x950 / 130x950x950 / 50x950x950 / 50x950x950								
	Weight		10.3 / 10.3 / 5.4 / 5.4								
Fan	Air flow rate	Cooling	Low/Medium/High	m³/min	12.2/16.7/21.2	19.0/25.7/32.3	19.9/26.7/33.5	21.1/27.3/33.5	19.0/25.7/32.3	19.9/26.7/33.5	21.1/27.3/33.5
		Heating	Low/Medium/High	m³/min	12.2/16.7/21.2	19.0/25.7/32.3	19.9/26.7/33.5	21.1/27.3/33.5	19.0/25.7/32.3	19.9/26.7/33.5	21.1/27.3/33.5
Sound power level	Cooling			dBA	53			61			
	Heating			dBA	53			61			
Sound pressure level	Cooling	Low/High		dBA	29/36	33/44	35/45	37/45	33/44	35/45	37/45
	Heating	Low/High		dBA	29/36	33/44	35/45	37/45	33/44	35/45	37/45
Control systems	Infrared remote control		BRC7FA532F								
	Wired remote control		BRC1H51 / BRC1E53A / BRC1E53B / BRC1E53C / BRC1D52								
Power supply	Phase/Frequency/Voltage		1~/50/60/220-240/220								

Outdoor unit		RZQSG	71L3V1	100L9V1	125L9V1	140L9V1	100L8Y1	125L8Y1	140LY1	
Dimensions	Unit	HeightxWidthxDepth	770x900x320	990x940x320		1,430x940x320	990x940x320		1,430x940x320	
Weight	Unit		67	72	74	95	82	101		
Sound power level	Cooling		65	70		69	70		69	
Sound pressure level	Cooling	Nom./Silent operation	dBA	49/47	53/-	54/-	53/-	54/-	53/-	
	Heating	Nom.	dBA	51	57	58	54	57	58	
Operation range	Cooling	Ambient	Min.~Max.	°CDB		-15~-46		-15~-46		
	Heating	Ambient	Min.~Max.	°CWB		-15~-15.5		-15~-15.5		
Refrigerant	Type/GWP		R-410A/2,087.5							
	Charge	kg/TCO2Eq	2.75/5.7	2.9/6.1		4.0/8.4	2.9/6.1		4.0/8.4	
Piping connections	Liquid/Gas		mm							
	Piping length	OU - IU	Max.	m						
		System	Equivalent	m						
			Chargeless	m						
	Additional refrigerant charge	kg/m	See installation manual							
	Level difference	IU - OU	Max.	m						
Power supply	Phase/Frequency/Voltage		1~/50/220-240		30.0		3N~/50/380-415			
Current - 50Hz	Maximum fuse amps (MFA)	A	20	32		-	16		20	

The BYCQ140D7W1W has white insulations. Be informed that formation of dirt on white insulation is visibly stronger and that it is consequently not advised to install the BYCQ140D7W1W decoration panel in environments exposed to concentrations of dirt. | BYCQ140D7W1: pure white standard panel with grey louvers; BYCQ140D7W1W: pure white standard panel with white louvers; BYCQ140D7GW1: pure white auto cleaning panel. | MFA is used to select the circuit breaker and the ground fault circuit interrupter (earth leakage circuit breaker). For more detailed information on each combination, please refer to the electrical data drawing.



Round flow cassette

360° air discharge for optimum efficiency and comfort

- › Combination with Seasonal Smart ensures best in class quality, highest efficiency and performance
- › Unified indoor unit range for R-32 and R-410A
- › Automatic filter cleaning results in higher efficiency & comfort and lower maintenance costs. 2 filters available: standard filter and finer mesh filter (for fine dust applications e.g. clothing shops)
- › Two optional intelligent sensors improve energy efficiency and comfort.
- › Individual flap control: flexibility to suit every room layout without changing the location of the unit!
- › Lowest installation height in the market: 214mm for class 20-63
- › Modern style decoration panel is available in 3 different variations: white (RAL9010) with grey louvers, full white (RAL9010) or auto cleaning panel
- › 5 different fan speeds available for maximum comfort
- › Reduced energy consumption thanks to specially developed small tube heat exchanger, DC fan motor and drain pump
- › Optional fresh air intake
- › Branch duct discharge allows to optimize air distribution in irregular shaped rooms or to supply air to small adjacent rooms



› Standard drain pump with 675mm lift increases flexibility and installation speed

Efficiency data		FCAG + RZQG	71A + 71L9V1	100A + 100L9V1	125A + 125L9V1	140A + 140L9V1	71A + 71L8Y1	100A + 100L8Y1	125A + 125L8Y1	140A + 140LY1	
Cooling capacity	Nom.	kW	6.80	9.50	12.0	13.4	6.80	9.50	12.0	13.4	
Heating capacity	Nom.	kW	7.50	10.8	13.5	15.5	7.50	10.8	13.5	15.5	
Power input	Cooling	Nom. kW	2.01	2.45	3.22	-	2.01	2.45	3.22	4.17	
	Heating	Nom. kW	1.89	2.60	3.72	-	1.89	2.60	3.72	4.30	
Seasonal efficiency (according to EN14825)	Cooling	Energy efficiency class	A++		A+		A++		A+		
		Pdesign	kW	6.80	9.50	12.00	-	6.80	9.50	12.00	-
		SEER		6.72	6.80	6.00	-	6.72	6.80	6.00	-
	Heating (Average climate)	Annual energy consumption	kWh	355	489	700	-	355	489	700	-
		Energy efficiency class		A+		A+		A+		A+	
		Pdesign	kW	6.33	11.30	12.66	-	6.33	11.30	12.66	-
Nominal efficiency	EER	SCOP/A		4.20	4.61	4.10	-	4.20	4.61	4.10	-
		Annual energy consumption	kWh	2,110	3,432	4,323	-	2,110	3,432	4,323	-
		COP		3.39	3.87	3.73	3.21	3.39	3.87	3.73	3.21
Annual energy consumption	Energy labeling Directive	Cooling/Heating	A/A		-		A/A		-		

Indoor unit		FCAG	71A	100A	125A	140A	71A	100A	125A	140A
Dimensions	Unit	HeightxWidthxDepth	mm	204x840x840	246x840x840		204x840x840	246x840x840		246x840x840
Weight	Unit		kg	21	24		21	24		
Air filter	Type			Resin net						
Decoration panel	Model			BYCQ140DGF9 - auto cleaning panel with fine mesh filter / BYCQ140DG9 - auto cleaning panel / BYCQ140DW - full white / BYCQ140D - white with grey louvers						
		Colour		Pure White (RAL 9010)						
	Dimensions	HeightxWidthxDepth	mm	130x950x950 / 130x950x950 / 50x950x950 / 50x950x950						
	Weight		kg	10.3 / 10.3 / 5.4 / 5.4						
Fan	Air flow rate	Cooling	Low/Medium/High	m ³ /min	9.3/12.5/15.3	12.4/17.6/22.8	12.4/19.2/26.0	9.3/12.5/15.3	12.4/17.6/22.8	12.4/19.2/26.0
		Heating	Low/Medium/High	m ³ /min	9.1/12.1/15.0	12.4/17.6/22.8	12.4/19.2/26.0	9.1/12.1/15.0	12.4/17.6/22.8	12.4/19.2/26.0
Sound power level	Cooling			dBA	51	54	58	51	54	58
		Heating		dBA	51	54	58	51	54	58
Sound pressure level	Cooling	Low/High		dBA	28/35	29/37	29/41	28/35	29/37	29/41
		Heating	Low/High	dBA	28/33	29/37	29/41	28/33	29/37	29/41
Control systems	Infrared remote control			BRC7FA532F						
	Wired remote control			BRC1H51 / BRC1E53A / BRC1E53B / BRC1E53C / BRC1D52						
Power supply	Phase/Frequency/Voltage		Hz/V	1~/50/60/220-240/220						

Outdoor unit		RZQG	71L9V1	100L9V1	125L9V1	140L9V1	71L8Y1	100L8Y1	125L8Y1	140LY1
Dimensions	Unit	HeightxWidthxDepth	mm	990x940x320	1,430x940x320		990x940x320	1,430x940x320		
Weight	Unit		kg	69	95		80	101		
Sound power level	Cooling			dBA	64	66	69	64	66	69
		Heating	Nom.	dBA	48	50	51	48	50	51
Sound pressure level	Cooling	Low/High		dBA	50	52	53	50	52	53
		Heating	Nom.	dBA	50	52	53	50	52	53
Operation range	Cooling	Ambient	Min.~Max.	°CDB	-15~50					
		Heating	Ambient	Min.~Max.	°CWB	-20~-15.5				
Refrigerant	Type/GWP			R-410A/2,087.5						
	Charge	kg/CO ₂ Eq		2.9/6.1	4.0/8.4		2.9/6.1	4.0/8.4		
Piping connections	Liquid/Gas		mm	9.52/15.9						
	Piping length	OU - IU	Max.	m	50	75	75	50	75	
	System	Equivalent		m	70	90	70	90		
	Chargeless			m	30					
	Additional refrigerant charge			kg/m	See installation manual					
Power supply	Level difference	IU - OU	Max.	m	30.0					
	Phase/Frequency/Voltage		Hz/V	1~/50/220-240						
Current - 50Hz	Maximum fuse amps (MFA)		A	25	40		16	25		

The BYCQ140D7W1W has white insulations. Be informed that formation of dirt on white insulation is visibly stronger and that it is consequently not advised to install the BYCQ140D7W1W decoration panel in environments exposed to concentrations of dirt. | BYCQ140D7W1: pure white standard panel with grey louvers; BYCQ140D7W1W: pure white standard panel with white louvers; BYCQ140D7GW1: pure white auto cleaning panel. | MFA is used to select the circuit breaker and the ground fault circuit interrupter (earth leakage circuit breaker). For more detailed information on each combination, please refer to the electrical data drawing.

Round flow cassette

360° air discharge for optimum efficiency and comfort

- › Combination with Seasonal Classic ensures good value for money for all types of commercial applications
- › Unified indoor unit range for R-32 and R-410A
- › Automatic filter cleaning results in higher efficiency & comfort and lower maintenance costs. 2 filters available: standard filter and finer mesh filter (for fine dust applications e.g. clothing shops)
- › Two optional intelligent sensors improve energy efficiency and comfort.
- › Individual flap control: flexibility to suit every room layout without changing the location of the unit!
- › Lowest installation height in the market: 214mm for class 20-63
- › Modern style decoration panel is available in 3 different variations: white (RAL9010) with grey louvers, full white (RAL9010) or auto cleaning panel



Indoor units

Efficiency data			FCAG + RZQSG	71A + 71L3V1	100A + 100L9V1	125A + 125L9V1	140A + 140L9V1	100A + 100L8Y1	125A + 125L8Y1	140A + 140LY1	
Cooling capacity	Nom.	kW	6.80	9.50	12.0	13.4	9.50	12.0	13.4		
Heating capacity	Nom.	kW	7.50	10.8	13.5	15.5	10.8	13.5	15.5		
Power input	Cooling	Nom.	kW	2.12	2.88	3.74	4.45	2.88	3.74	4.45	
	Heating	Nom.	kW	2.08	3.05	3.96	4.54	3.05	3.96	4.54	
Seasonal efficiency (according to EN14825)	Cooling	Energy efficiency class		A++		A	-	A++	A	-	
		Pdesign	kW	6.80	9.50	12.00	-	9.50	12.00	-	
		SEER		6.10	6.50	5.30	-	6.50	5.30	-	
		Annual energy consumption	kWh	391	512	793	-	512	793	-	
	Heating (Average climate)	Energy efficiency class		A+		-	-	A+	-	-	
		Pdesign	kW	6.33	7.60	8.03	-	7.60	8.03	-	
SCOP/A			4.10		4.01	-	4.10	4.01	-		
	Annual energy consumption	kWh	2,162	2,596	2,804	-	2,596	2,804	-		
Nominal efficiency	EER		3.21	3.30	3.21	3.01	3.30	3.21	3.01		
	COP		3.61	3.54		3.41	3.54		3.41		
	Annual energy consumption	kWh	1,060	1,440	1,870	-	1,440	1,870	2,225		
	Energy labeling Directive	Cooling/Heating		A/A		A/B	-/-	A/A	A/B	-/-	
Indoor unit			FCAG	71A	100A	125A	140A	100A	125A	140A	
Dimensions	Unit	HeightxWidthxDp	mm	204x840x840		246x840x840		246x840x840			
Weight	Unit		kg	21		24		24			
Air filter	Type			Resin net							
Decoration panel	Model			BYCQ140DGF9 - auto cleaning panel with fine mesh filter / BYCQ140DG9 - auto cleaning panel / BYCQ140DW - full white / BYCQ140D - white with grey louvers							
	Colour			Pure White (RAL 9010)							
	Dimensions	HeightxWidthxDp	mm	130x950x950 / 130x950x950 / 50x950x950 / 50x950x950							
	Weight		kg	10.3 / 10.3 / 5.4 / 5.4							
Fan	Air flow rate	Cooling	Low/Medium/High	m ³ /min	9.3/12.5/15.3	12.4/17.6/22.8	12.4/19.2/26.0	12.4/17.6/22.8	12.4/19.2/26.0		
		Heating	Low/Medium/High	m ³ /min	9.1/12.1/15.0	12.4/17.6/22.8	12.4/19.2/26.0	12.4/17.6/22.8	12.4/19.2/26.0		
Sound power level	Cooling			dBA	51	54	58	54	58		
	Heating			dBA	51	54	58	54	58		
Sound pressure level	Cooling	Low/High		dBA	28/35	29/37	29/41	29/37	29/41		
	Heating	Low/High		dBA	28/33	29/37	29/41	29/37	29/41		
Control systems	Infrared remote control			BRC7FA532F							
	Wired remote control			BRC1H51 / BRC1E53A / BRC1E53B / BRC1E53C / BRC1D52							
Power supply	Phase/Frequency/Voltage		Hz/V	1~/50/60/220-240/220							
Outdoor unit			RZQSG	71L3V1	100L9V1	125L9V1	140L9V1	100L8Y1	125L8Y1	140LY1	
Dimensions	Unit	HeightxWidthxDp	mm	770x900x320		990x940x320		990x940x320		1,430x940x320	
Weight	Unit		kg	67	72	74	95	82	101		
Sound power level	Cooling			dBA	65	70	69	70	69		
Sound pressure level	Cooling	Nom./Silent operation		dBA	49/47	53/-	54/-	53/-	54/-	53/-	
	Heating	Nom.		dBA	51	57	58	54	57	54	
Operation range	Cooling	Ambient	Min.~Max.	°CDB	-15.0~46		-15~46				
	Heating	Ambient	Min.~Max.	°CWB	-15~-15.5						
Refrigerant	Type/GWP			R-410A/2,087.5							
	Charge		kg/CO ₂ Eq	2.75/5.7	2.9/6.1	4.0/8.4	2.9/6.1	4.0/8.4			
Piping connections	Liquid/Gas		mm	9.52/15.9							
	Piping length	OU - IU	Max.	m	50						
		System	Equivalent	m	70						
		Chargeless		m	30						
		Additional refrigerant charge		kg/m	See installation manual						
Power supply	Phase/Frequency/Voltage		Hz/V	15	1~/50/220-240		30.0	3N~/50/380-415			
Current - 50Hz	Maximum fuse amps (MFA)		A	20	32		-	16	20		

The BYCQ140D7W1W has white insulations. Be informed that formation of dirt on white insulation is visibly stronger and that it is consequently not advised to install the BYCQ140D7W1W decoration panel in environments exposed to concentrations of dirt. | BYCQ140D7W1: pure white standard panel with grey louvers; BYCQ140D7W1W: pure white standard panel with white louvers; BYCQ140D7GW1: pure white auto cleaning panel. | MFA is used to select the circuit breaker and the ground fault circuit interrupter (earth leakage circuit breaker). For more detailed information on each combination, please refer to the electrical data drawing.



Round flow cassette

360° air discharge for optimum efficiency and comfort

- › Unified indoor unit range for R-32 and R-410A
- › Automatic filter cleaning results in higher efficiency & comfort and lower maintenance costs. 2 filters available: standard filter and finer mesh filter (for fine dust applications e.g. clothing shops)
- › Two optional intelligent sensors improve energy efficiency and comfort.
- › Individual flap control: flexibility to suit every room layout without changing the location of the unit!
- › Lowest installation height in the market: 214mm for class 20-63
- › Modern style decoration panel is available in 3 different variations: white (RAL9010) with grey louvers, full white (RAL9010) or auto cleaning panel



Efficiency data		FCAG + AZQS	71A + 71BV1	100A + 100B8V1	125A + 125B8V1	140A + 140B8V1	100A + 100BY1	125A + 125BY1	140A + 140BY1	
Cooling capacity	Nom.	kW	6.80	9.5	12.1	13.0	9.5	12.1	13.0	
Heating capacity	Nom.	kW	7.50	10.8	13.5	15.5	10.8	13.5	15.5	
Power input	Cooling	Nom.	kW	2.19	2.96	3.90	4.63	2.96	4.63	
	Heating	Nom.	kW	2.08	3.09	3.96	4.70	3.09	4.70	
Seasonal efficiency (according to EN14825)	Cooling	Energy efficiency class		A+	A	-	A	-	-	
		Pdesign	kW	6.80	9.50	-	9.50	-	-	
		SEER		5.70	5.50	-	5.50	-	-	
	Heating (Average climate)	Annual energy consumption	kWh	418	605	-	605	-	-	
		Energy efficiency class		A+	A	-	A	-	-	
		Pdesign	kW	6.33	7.60	-	7.60	-	-	
Nominal efficiency	EER		3.11	3.21	3.10	2.81	3.21	3.10	2.81	
	COP		3.61	3.50	3.41	3.30	3.50	3.41	3.30	
	Annual energy consumption	kWh	1,093	1,480	1,952	2,313	1,480	1,952	2,313	
Energy labeling Directive	Cooling/Heating		B / A	A/B	B/B	C/C	A/B	B/B	-/-	
Indoor unit		FCAG	71A	100A	125A	140A	100A	125A	140A	
Dimensions	Unit	HeightxWidthxDPTH	mm	204x840x840		246x840x840				
Weight	Unit		kg	21	24					
Air filter	Type			Resin net						
Decoration panel	Model			BYCQ140DGF9 - auto cleaning panel with fine mesh filter / BYCQ140DG9 - auto cleaning panel / BYCQ140DW - full white / BYCQ140D - white with grey louvers						
	Colour			Pure White (RAL 9010)						
Dimensions	Unit	HeightxWidthxDPTH	mm	130x950x950 / 130x950x950 / 50x950x950 / 50x950x950						
	Weight		kg	10.3 / 10.3 / 5.4 / 5.4						
Fan	Air flow rate	Cooling	Low/Medium/High	m ³ /min	9.3/12.5/15.3	12.4/17.6/22.8	12.4/19.2/26.0	12.4/17.6/22.8	12.4/19.2/26.0	
		Heating	Low/Medium/High	m ³ /min	9.1/12.1/15.0	12.4/17.6/22.8	12.4/19.2/26.0	12.4/17.6/22.8	12.4/19.2/26.0	
Sound power level	Cooling			dBA	51	54	58	54	58	
	Heating			dBA	51	54	58	54	58	
Sound pressure level	Cooling	Low/High		dBA	28/35	29/37	29/41	29/37	29/41	
	Heating	Low/High		dBA	28/33	29/37	29/41	29/37	29/41	
Control systems	Infrared remote control			BRC7FA532F						
	Wired remote control			BRC1H51 / BRC1E53A / BRC1E53B / BRC1E53C / BRC1D52						
Power supply	Phase/Frequency/Voltage		Hz/V	1~/50/60/220-240/220						
Outdoor unit		AZQS/AZQS	71BV1	100B8V1	125B8V1	140B8V1	100BY1	125BY1	140BY1	
Dimensions	Unit	HeightxWidthxDPTH	mm	770x900x320	990x940x320		1,430x940x320	990x940x320	1,430x940x320	
Weight	Unit		kg	67	72.8	74.3	94.9	82	101	
Sound power level	Cooling			dBA	64	70	71	70	71	
Sound pressure level	Cooling	Nom.		dBA	48	53	54	53	54	
	Heating	Nom.		dBA	50	57	58	54	57	
Operation range	Night quiet mode	Level 1		dBA	43	49				
	Cooling	Ambient	Min.~Max.	°CDB	-5~-46					
Refrigerant	Heating	Ambient	Min.~Max.	°CWB	-15~-15.5					
	Type/GWP				R-410A/2,087.5					
Piping connections	Charge		kg/TCO2Eq	2.75/5.7	2.9/6.1	4.0/8.4	2.9/6.1	4.0/8.4		
	Liquid/Gas		mm	9.52/15.9						
Additional refrigerant charge	Piping length	OU - IU	Max.	m	50					
	System	Equivalent		m	70					
	Chargeless			m	30					
	Level difference	IU - OU	Max.	m	See installation manual					
Power supply	Phase/Frequency/Voltage		Hz/V	1~/50/220-240				3N~/50/380-415		
Current - 50Hz	Maximum fuse amps (MFA)		A	20	32		16	20		

EER/COP according to Eurovent 2012, for use outside EU only | The BYCQ140D7W1W has white insulations. Be informed that formation of dirt on white insulation is visibly stronger and that it is consequently not advised to install the BYCQ140D7W1W decoration panel in environments exposed to concentrations of dirt. | BYCQ140D7W1: pure white standard panel with grey louvers; BYCQ140D7W1W: pure white standard panel with white louvers; BYCQ140D7GW1: pure white auto cleaning panel.



Round flow cassette

360° air discharge for optimum efficiency and comfort

- › Combination with split outdoor units is ideal for small retail, offices or residential applications
- › Unified indoor unit range for R-32 and R-410A
- › Automatic filter cleaning results in higher efficiency & comfort and lower maintenance costs. 2 filters available: standard filter and finer mesh filter (for fine dust applications e.g. clothing shops)
- › Two optional intelligent sensors improve energy efficiency and comfort.
- › Individual flap control: flexibility to suit every room layout without changing the location of the unit!
- › Lowest installation height in the market: 214mm for class 20-63
- › Modern style decoration panel is available in 3 different variations: white (RAL9010) with grey louvers, full white (RAL9010) or auto cleaning panel



Indoor units

Efficiency data		FCAG + RXS		35A + 35L3		50A + 50L		60A + 60L		
Cooling capacity	Nom.	kW		3.40		5.00		5.70		
Heating capacity	Nom.	kW		4.20		6.00		7.00		
Power input	Cooling	Nom.	kW	0.91		1.41		1.64		
	Heating	Nom.	kW	1.20		1.62		1.99		
Seasonal efficiency (according to EN14825)	Cooling	Energy efficiency class		A++		A++		A++		
		Pdesign	kW	3.50		5.00		5.70		
		SEER		6.35		6.48		6.22		
	Heating (Average climate)	Annual energy consumption		kWh	193		270		321	
		Energy efficiency class			A++		A++		A+	
		Pdesign	kW	3.32		4.36		4.71		
Nominal efficiency	COP	SCOP/A		kW	4.90		4.29		4.00	
		Annual energy consumption		kWh	949		1,426		1,646	
		Energy labeling Directive		Cooling/Heating	A/B		A/A		A/B	
Annual energy consumption		kWh		455		705		820		

Indoor unit		FCAG		35A		50A		60A		
Dimensions	Unit	HeightxWidthxDpeth		mm		204x840x840				
Weight	Unit	kg		18		19				
Air filter	Type	Resin net								
Decoration panel	Model	BYCQ140DGF9 - auto cleaning panel with fine mesh filter / BYCQ140DG9 - auto cleaning panel / BYCQ140DW - full white / BYCQ140D - white with grey louvers								
	Colour	Pure White (RAL 9010)								
Dimensions	Unit	HeightxWidthxDpeth		mm		130x950x950 / 130x950x950 / 50x950x950 / 50x950x950				
	Weight	kg		10.3 / 10.3 / 5.4 / 5.4						
Fan	Air flow rate	Cooling	Low/Medium/High	m³/min		8.7/10.6/12.5		8.7/10.7/12.6		
		Heating	Low/Medium/High	m³/min		9.3/11.6/13.9		8.7/10.7/12.6		
Sound power level	Cooling	dBA		49		51				
	Heating	dBA		49		51				
Sound pressure level	Cooling	Low/High	dBA		27/31		28/33			
	Heating	Low/High	dBA		27/31		28/33			
Control systems	Infrared remote control		BRC7FA532F							
	Wired remote control		BRC1H51 / BRC1E53A / BRC1E53B / BRC1E53C / BRC1D52							
Power supply	Phase/Frequency/Voltage		Hz/V		1~/50/60/220-240/220					

Outdoor unit		RXS		35L3		50L		60L		
Dimensions	Unit	HeightxWidthxDpeth		mm		550x765x285		735x825x300		
Weight	Unit	kg		34		47		48		
Sound power level	Cooling	dBA		61		62				
	Heating	dBA		61		62				
Sound pressure level	Cooling	Low/High	dBA		-48		44/48		46/49	
	Heating	Low/High	dBA		-48		45/48		46/49	
Operation range	Cooling	Ambient	Min.~Max.	°CDB		-10~-46				
	Heating	Ambient	Min.~Max.	°CWB		-15~-18				
Refrigerant	Type	R-410A								
	GWP	2,087.5								
Piping connections	Charge	kg/CO2Eq		1.2/2.5		1.7/3.5		1.5/3.1		
	Liquid	OD	mm		6.35					
Piping connections	Gas	OD	mm		9.5		12.7			
	Piping length	OU - IU	Max.	m		20		30		
Piping connections	length	System	Chargeless	m		10				
	Additional refrigerant charge	kg/m		0.02 (for piping length exceeding 10m)		0.020 (for piping length exceeding 10m)				
Power supply	Level difference	IU - OU	Max.	m		15		20.0		
	Phase/Frequency/Voltage	Hz/V		1~/50/220-240		1~/50/220-230-240				
Current - 50Hz	Maximum fuse amps (MFA)		A							

EER/COP according to Eurovent 2012, for use outside EU only | The BYCQ140D7W1W has white insulations. Be informed that formation of dirt on white insulation is visibly stronger and that it is consequently not advised to install the BYCQ140D7W1W decoration panel in environments exposed to concentrations of dirt. | BYCQ140D7W1: pure white standard panel with grey louvers; BYCQ140D7W1W: pure white standard panel with white louvers; BYCQ140D7GW1: pure white auto cleaning panel.

Fully flat cassette

Unique design in the market that integrates fully flat into the ceiling

- › Combination with split outdoor units is ideal for small retail, offices or residential applications
- › Fully flat integration in standard architectural ceiling tiles, leaving only 8mm
- › Remarkable blend of iconic design and engineering excellence with an elegant finish in white or a combination of silver and white
- › Unified indoor unit range for R-32 and R-410A
- › Two optional intelligent sensors improve energy efficiency and comfort.
- › Individual flap control: flexibility to suit every room layout without changing the location of the unit!
- › Reduced energy consumption thanks to specially developed small tube heat exchanger, DC fan motor and drain pump
- › Optional fresh air intake
- › Branch duct discharge allows to optimize air distribution in irregular shaped rooms or to supply air to small adjacent rooms
- › Standard drain pump with 630mm lift increases flexibility and installation speed



Efficiency data		FFA + RXS	25A + 25L3	35A + 35L3	50A + 50L	60A + 60L	
Cooling capacity	Nom.	kW	2.50	3.40	5.00	5.70	
Heating capacity	Nom.	kW	3.20	4.20	5.80	7.00	
Power input	Cooling	Nom. kW	0.55	0.90	1.56	1.89	
	Heating	Nom. kW	0.82	1.20	1.66	2.05	
Seasonal efficiency (according to EN14825)	Cooling	Energy efficiency class	A++		A+		
		Pdesign	kW	2.50	3.40	5.00	5.70
		SEER		6.11	6.32	5.93	5.71
	Heating (Average climate)	Annual energy consumption	kWh	143	188	295	349
		Energy efficiency class		A+		A	
		Pdesign	kW	2.31	3.10	3.84	3.96
Nominal efficiency	EER	SCOP/A	4.24	4.10	3.90	4.04	
		Annual energy consumption	kWh	763	1,059	1,378	1,373
	COP		4.53	3.78	3.21	3.02	
			3.90	3.50	3.49	3.41	
Annual energy consumption	kWh	276	450	780	945		
Energy labeling Directive	Cooling/Heating		A/A		A/B		

Indoor unit		FFA	25A	35A	50A	60A	
Dimensions	Unit HeightxWidthxDepth	mm	260x575x575				
Weight	Unit	kg	16.0		17.5		
Air filter	Type		Resin net				
Decoration panel	Model		BYFQ60C2W1W/BYFQ60C2W1S/BYFQ60B2W1/BYFQ60B3W1				
	Colour		White (N9.5)/SILVER/White (RAL9010)/WHITE (RAL9010)				
Dimensions	HeightxWidthxDepth	mm	46x620x620 / 46x620x620 / 55x700x700 / 55x700x700				
	Weight	kg	2.8/2.8/2.7/2.7				
Fan	Air flow rate Cooling	Low/Medium/High	m³/min	6.5/8.0 /9.0	6.5/8.5 /10.0	7.5/10.0 /12.0	9.5/12.5 /14.5
	Heating	Low/Medium/High	m³/min	6.5/8.0 /9.0	6.5/8.5 /10.0	7.5/10.0 /12.0	9.5/12.5 /14.5
Sound power level	Cooling		dBA	48	51	56	60
Sound pressure level	Cooling	Low/High	dBA	25.0/31.0	25.0/34.0	27.0/39.0	32.0/43.0
	Heating	Low/High	dBA	25.0/31.0	25.0/34.0	27.0/39.0	32.0/43.0
Control systems	Infrared remote control		BRC7EB530W (standard panel) / BRC7F530W (white panel) / BRC7F530S (grey panel)				
	Wired remote control		BRC1H51 / BRC1E53A / BRC1E53B / BRC1E53C / BRC1D52				
Power supply	Phase/Frequency/Voltage	Hz/V	1~/50/220-240				

Outdoor unit		RXS	25L3	35L3	50L	60L	
Dimensions	Unit HeightxWidthxDepth	mm	550x765x285		735x825x300		
Weight	Unit	kg	34		47	48	
Sound power level	Cooling		dBA	59	61	62	
	Heating		dBA	59	61	62	
Sound pressure level	Cooling	Low/High	dBA	-/46	-/48	44/48	46/49
	Heating	Low/High	dBA	-/47	-/48	45/48	46/49
Operation range	Cooling	Ambient	Min.~Max.	°CDB -10~46			
	Heating	Ambient	Min.~Max.	°CWB -15~18			
Refrigerant	Type		R-410A				
	GWP		2,087.5				
Piping connections	Charge	kg/CO2Eq	1.0/2.1	1.2/2.5	1.7/3.5	1.5/3.1	
	Liquid	OD	mm	6.35			
	Gas	OD	mm	9.5		12.7	
	Piping length	OU - IU Max. Chargeless	m	20		30	
	Additional refrigerant charge	kg/m	0.02 (for piping length exceeding 10m)		0.020 (for piping length exceeding 10m)		
	Level difference	IU - OU Max.	m	15			
Power supply	Phase/Frequency/Voltage	Hz/V	1~/50/220-240		1~/50/220-230-240		
Current - 50Hz	Maximum fuse amps (MFA)	A	-				



Concealed ceiling unit

Compact concealed ceiling unit, with a height of only 200mm

- › Invisible unit as the unit is concealed in the ceiling: only the suction and discharge grilles are visible
- › Compact dimensions, can easily be mounted in a ceiling void of only 240mm
- › Medium external static pressure up to 40Pa facilitates unit use with flexible ducts of varying lengths
- › Unified indoor unit range for R-32 and R-410A
- NEW** › Auto cleaning filter option ensures maximum efficiency, comfort and reliability by regular filter cleaning
- NEW** › Multi zoning kit allows multiple individually-controlled climate zones to be served by one indoor unit
- › Online controller (optional): control your indoor from any location with an app, via your local network or internet and keep an overview on your energy consumption
- › Low energy consumption thanks to DC fan motor



Efficiency data		FDXM + RXS		25F3 + 25L3	35F3 + 35L3	50F3 + 50L	60F3 + 60L
Cooling capacity	Nom.	kW		2.40	3.40	5.00	6.00
Heating capacity	Nom.	kW		3.20	4.00	5.80	7.00
Power input	Cooling	Nom.	kW	0.64	1.15	1.65	2.06
	Heating	Nom.	kW	0.80	1.15	1.87	2.18
Seasonal efficiency (according to EN14825)	Cooling	Energy efficiency class		A+	A	A+	A
		Pdesign	kW	2.40	3.40	5.00	6.00
		SEER		5.63	5.21	5.72	5.51
	Annual energy consumption		kWh	149	228	306	381
	Heating (Average climate)	Energy efficiency class		A+		A	
		Pdesign	kW	2.60	2.90	4.00	4.60
SCOP/A			4.24	3.88	3.93	3.80	
Annual energy consumption		kWh	858	1,047	1,425	1,693	
Nominal efficiency	EER			3.74	2.96	3.03	2.91
	COP			4.00	3.48	3.10	3.21
	Annual energy consumption		kWh	321	574	825	1,030
	Energy labeling Directive		Cooling/Heating	A/A	B/A	B/D	C/C

Indoor unit		FDXM		25F3	35F3	50F3	60F3	
Dimensions	Unit	HeightxWidthxDepth		200x750x620		200x1,150x620		
Weight	Unit	kg		21		28		
Air filter	Type			Removable / washable				
Fan	Air flow rate	Cooling	Low/Medium/High	m³/min		7.3/8.0 / 8.7		
		Heating	Low/Medium/High	m³/min		7.3/8.0 / 8.7		
	External static pressure	Nom.	Pa	30		40		
Sound power level	Cooling	dBA		53		55		
	Heating	dBA		53		55		
Sound pressure level	Cooling	Low/High	dBA	27/35		30/38		
	Heating	Low/High	dBA	27/35		30/38		
Control systems	Infrared remote control		BRC4C65					
	Wired remote control		BRC1H51 / BRC1E53A / BRC1E53B / BRC1E53C / BRC1D52					
Power supply	Phase/Frequency/Voltage		Hz/V					
				1~/50/220-240				

Outdoor unit		RXS		25L3	35L3	50L	60L	
Dimensions	Unit	HeightxWidthxDepth		550x765x285		735x825x300		
Weight	Unit	kg		34		47		
Sound power level	Cooling	dBA		59		61		
	Heating	dBA		59		61		
Sound pressure level	Cooling	Low/High	dBA	-/46		44/48		
	Heating	Low/High	dBA	-/47		45/48		
Operation range	Cooling	Ambient	Min.~Max.	°CDB				
	Heating	Ambient	Min.~Max.	°CWB				
Refrigerant	Type	R-410A						
	GWP	2,087.5						
Piping connections	Charge	kg/CO2Eq		1.0/2.1		1.2/2.5		
	Liquid	OD	mm	6.35		1.7/3.5		
	Gas	OD	mm	9.5		12.7		
	Piping length	OU - IU	Max.	20		30		
	System	Chargeless	m	10		-		
	Additional refrigerant charge	kg/m		0.02 (for piping length exceeding 10m)				
Power supply	Level difference	IU - OU	Max.	m		15		
	Phase/Frequency/Voltage	Hz/V		1~/50/220-240		1~/50/220-230-240		
Current - 50Hz	Maximum fuse amps (MFA)		A					
				-				

Nominal cooling capacities are based on: indoor temperature: 27°CDB, 19°CWB, outdoor temperature: 35°CDB, equivalent refrigerant piping: 5m, level difference: 0m. | Nominal heating capacities are based on: indoor temperature: 20°CDB, outdoor temperature: 7°CDB, 6°CWB, equivalent refrigerant piping: 5m, level difference: 0m.

Concealed ceiling unit with medium ESP

Slimmest yet most powerful medium static pressure unit on the market

- › Combination with Seasonal Smart ensures best in class quality, highest efficiency and performance
- › Slimmest unit in class, only 245mm (300mm built-in height) and therefore narrow ceiling voids are no longer a challenge
- › Low operation sound level down to 25dBA
- › Medium external static pressure up to 150Pa facilitates using flexible ducts of varying lengths
- › Unified indoor unit range for R-32 and R-410A
- › Possibility to change ESP via wired remote control allows optimisation of the supply air volume
- › Discretely concealed in the ceiling: only the suction and discharge grilles are visible

NEW

- › Multi zoning kit allows multiple individually-controlled climate zones to be served by one indoor unit
- › Reduced energy consumption thanks to specially developed DC fan motor
- › Optional fresh air intake



- › Flexible installation: air suction direction can be altered from rear to bottom suction and choice between free use or connection to optional suction grilles
- › Standard built-in drain pump with 625mm lift increases flexibility and installation speed

Efficiency data		FBA + RZQG	71A + 71L9V1	100A + 100L9V1	125A + 125L9V1	140A + 140L9V1	71A + 71L8Y1	100A + 100L8Y1	125A + 125L8Y1	140A + 140L8Y1	
Cooling capacity	Nom.	kW	6.8	9.5	12.0	13.4	6.8	9.5	12.0	13.4	
Heating capacity	Nom.	kW	7.50	10.80	13.50	15.5	7.50	10.80	13.50	15.5	
Power input	Cooling	Nom.	1.89	2.49	3.63	4.00	1.89	2.49	3.63	4.00	
	Heating	Nom.	1.87	2.45	3.46	4.31	1.87	2.45	3.46	4.31	
Seasonal efficiency (according to EN14825)	Cooling	Energy efficiency class	A++	A+	A++	-	A++	A+	A++	-	
		Pdesign	6.80	9.50	12.00	-	6.80	9.50	12.00	-	
		SEER	6.16	5.87	6.11	-	6.16	5.87	6.11	-	
	Heating (Average climate)	Annual energy consumption	kWh	386	566	687	-	386	566	687	-
		Energy efficiency class	A+	A++	A+	-	A+	A++	A+	-	
		Pdesign	6.00	11.30	12.70	-	6.00	11.30	12.70	-	
Nominal efficiency	EER	SCOP/A	4.31	4.78	4.28	-	4.31	4.78	4.28	-	
		Annual energy consumption	kWh	1,949	3,310	4,154	-	1,949	3,310	4,154	-
	COP	EER	3.60	3.81	3.31	3.35	3.60	3.81	3.31	3.35	
		Annual energy consumption	kWh	944	1,247	1,813	-	944	1,247	1,813	-
Energy labeling Directive	Cooling/Heating		A/A			-/-		A/A		-/-	

Indoor unit		FBA	71A	100A	125A	140A	71A	100A	125A	140A
Dimensions	Unit HeightxWidthxDepth	mm	245x1,000x800		245x1,400x800		245x1,000x800		245x1,400x800	
Weight	Unit	kg	35.0		46.0		35.0		46.0	
Air filter	Type		Resin net							
Fan	Air flow rate	Cooling	Low/Medium/High	m ³ /min	125/15.0/18.0	23.0/26.0/29.0	23.5/29.0/34.0	125/15.0/18.0	23.0/26.0/29.0	23.5/29.0/34.0
		Heating	Low/Medium/High	m ³ /min	125/15.0/18.0	23.0/26.0/29.0	23.5/29.0/34.0	125/15.0/18.0	23.0/26.0/29.0	23.5/29.0/34.0
External static pressure	Nom./High			Pa	30/150	40/150	50/150	30/150	40/150	50/150
				dBA	56	58	62	56	58	62
Sound power level	Cooling			dBA	25.0/30.0	30.0/34.0	32.0/37.0	25.0/30.0	30.0/34.0	32.0/37.0
	Heating			dBA	25.0/31.0	30.0/36.0	32.0/38.0	25.0/31.0	30.0/36.0	32.0/38.0
Control systems	Infrared remote control		BRC4C65 / BRC4C66							
	Wired remote control		BRC1H51 / BRC1E53A / BRC1E53B / BRC1E53C / BRC1D52							
Power supply	Phase/Frequency/Voltage	Hz/V	1~/50/60/220-240/220							

Outdoor unit		RZQG	71L9V1	100L9V1	125L9V1	140L9V1	71L8Y1	100L8Y1	125L8Y1	140L8Y1	
Dimensions	Unit HeightxWidthxDepth	mm	990x940x320		1,430x940x320		990x940x320		1,430x940x320		
Weight	Unit	kg	69		95		80		101		
Sound power level	Cooling			dBA	64	66	67	69	64	66	67
	Heating			dBA	48	50	51	52	48	50	51
Sound pressure level	Cooling	Nom.									
	Heating	Nom.				53		50	52	53	
Operation range	Cooling	Ambient	Min.~Max.	-15~50							
	Heating	Ambient	Min.~Max.	-20~15.5							
Refrigerant	Type/GWP		R-410A/2,087.5								
	Charge	kg/CO ₂ Eq	2.9/6.1		4.0/8.4		2.9/6.1		4.0/8.4		
Piping connections	Liquid/Gas	mm	9.52/15.9								
	Piping length	OU - IU	Max.	m	50		75		50		75
		System	Equivalent	m	70		90		70		90
		Chargeless	m	30							
		Additional refrigerant charge	kg/m	See installation manual							
Power supply	Level difference	IU - OU	Max.	30.0							
	Phase/Frequency/Voltage	Hz/V	1~/50/220-240				3N~/50/380-415				
Current - 50Hz	Maximum fuse amps (MFA)	A	25		40		16		25		

MFA is used to select the circuit breaker and the ground fault circuit interrupter (earth leakage circuit breaker). For more detailed information on each combination, please refer to the electrical data drawing.

Concealed ceiling unit with medium ESP

Slimmest yet most powerful medium static pressure unit on the market

- > Combination with Seasonal Classic ensures good value for money for all types of commercial applications
- > Slimmest unit in class, only 245mm (300mm built-in height) and therefore narrow ceiling voids are no longer a challenge
- > Low operation sound level down to 25dBA
- > Medium external static pressure up to 150Pa facilitates using flexible ducts of varying lengths
- > Unified indoor unit range for R-32 and R-410A
- > Possibility to change ESP via wired remote control allows optimisation of the supply air volume
- > Discretely concealed in the ceiling: only the suction and discharge grilles are visible
- NEW** > Multi zoning kit allows multiple individually-controlled climate zones to be served by one indoor unit



Optimised supply air volume

Automatically selects the most appropriate fan curve to achieve the units' nominal air flow within ±10%

Why?

After installation the real ducting will frequently differ from the initially calculated air flow resistance → the real air flow may be much lower or higher than nominal, leading to a lack of capacity or uncomfortable air temperature

Automatic Airflow Adjustment function will adapt the unit's fan speed to any ducting automatically (10 or more fan curves are available on every model), making installation much faster

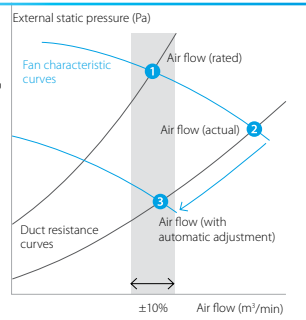

Efficiency data			FBA + RZQSG	71A + 71L3V1	100A + 100L9V1	125A + 125L9V1	140A + 140L9V1	100A + 100L8Y1	125A + 125L8Y1	140A + 140LY1		
Cooling capacity	Nom.	kW	6.80	9.5	12.0	13.4	9.5	12.0	13.4	13.4		
Heating capacity	Nom.	kW	7.50	10.80	13.50	15.5	10.80	13.50	15.5	15.5		
Power input	Cooling	Nom. kW	1.98	2.84	3.72	4.38	2.84	3.72	4.38	4.38		
	Heating	Nom. kW	1.91	2.94	3.72	4.56	2.94	3.72	4.56	4.56		
Seasonal efficiency (according to EN14825)	Cooling	Energy efficiency class	A+		A		A+		A			
		Pdesign	kW	6.80	9.50	12.00	-	9.50	12.00	-		
		SEER		5.84	5.61	5.47	-	5.61	5.47	-		
	Heating (Average climate)	Annual energy consumption	kWh	408	593	768	-	593	768	-		
		Energy efficiency class	A+		-		-		A+		-	
		Pdesign	kW	6.00	7.60	-	-	7.60	-	-		
Nominal efficiency	EER	SCOP/A	4.01	4.15	4.01	-	4.15	4.01	-			
		Annual energy consumption	kWh	2,095	2,564	2,653	-	2,564	2,653	-		
	COP	COP	3.43	3.35	3.23	3.06	3.35	3.23	3.06			
		Annual energy consumption	kWh	991	1,418	1,858	-	1,418	1,858	-		
Energy labeling Directive		Cooling/Heating	A/A	A/A	A/A	-/-	A/A	A/A	-/-			
Indoor unit			FBA	71A	100A	125A	140A	100A	125A	140A		
Dimensions	Unit	HeightxWidthxDepth	mm	245x1,000x800	245x1,400x800							
Weight	Unit		kg	35.0	46.0							
Air filter	Type			Resin net								
Fan	Air flow rate	Cooling	Low/Medium/High	m³/min	12.5/15.0 /18.0	23.0/26.0 /29.0	23.5/29.0 /34.0	23.0/26.0 /29.0	23.5/29.0 /34.0			
		Heating	Low/Medium/High	m³/min	12.5/15.0 /18.0	23.0/26.0 /29.0	23.5/29.0 /34.0	23.0/26.0 /29.0	23.5/29.0 /34.0			
External static pressure	Nom./High			Pa	30/150	40/150	50/150	40/150	50/150			
		Cooling	Low/High	dBA	56	58	62	58	62			
Sound pressure level	Cooling	Low/High		dBA	25.0/30.0	30.0/34.0	32.0/37.0	30.0/34.0	32.0/37.0			
		Heating	Low/High	dBA	25.0/31.0	30.0/36.0	32.0/38.0	30.0/36.0	32.0/38.0			
Control systems		Infrared remote control		BRC4C65 / BRC4C66								
		Wired remote control		BRC1H51 / BRC1E53A / BRC1E53B / BRC1E53C / BRC1D52								
Power supply		Phase/Frequency/Voltage		1~/50/60/220-240/220								
Outdoor unit			RZQSG	71L3V1	100L9V1	125L9V1	140L9V1	100L8Y1	125L8Y1	140LY1		
Dimensions	Unit	HeightxWidthxDepth	mm	770x900x320	990x940x320			1,430x940x320	990x940x320			
Weight	Unit		kg	67	72	74	95	82	101			
Sound power level	Cooling	Nom./Silent operation	dBA	65	70	70	69	70	69			
Sound pressure level	Cooling	Nom.	dBA	49/47	53/-	54/-	53/-	54/-	53/-			
		Heating	Nom.	dBA	51	57	58	54	57	58		
Operation range	Cooling	Ambient	Min.~Max.	°CDB	-15.0~46	-15~46			-15~46			
		Heating	Ambient	Min.~Max.	°CWB	-15~15.5						
Refrigerant		Type/GWP		R-410A/2,087.5								
		Charge	kg/CO2Eq	2.75/5.7	2.9/6.1	4.0/8.4	2.9/6.1	4.0/8.4				
Piping connections	Liquid/Gas		mm	9.52/15.9			9.52/15.9		9.52/15.9			
		Piping length	OU - IU	Max. m	50			50				
	Additional refrigerant charge	IU - OU	System	Max. m	70			70				
			Chargeless	Max. m	30			30				
		Level difference	kg/m	See installation manual								
Power supply		Phase/Frequency/Voltage		15	30.0			30.0				
Current - 50Hz		Maximum fuse amps (MFA)	A	20	1~/50/220-240			3N~/50/380-415				
				20	32			16				

MFA is used to select the circuit breaker and the ground fault circuit interrupter (earth leakage circuit breaker). For more detailed information on each combination, please refer to the electrical data drawing.

Concealed ceiling unit with medium ESP

Slimmest yet most powerful medium static pressure unit on the market

- > Combination with split outdoor units is ideal for small retail, offices or residential applications
- > Slimmest unit in class, only 245mm (300mm built-in height) and therefore narrow ceiling voids are no longer a challenge
- > Low operation sound level down to 25dBA
- > Medium external static pressure up to 150Pa facilitates using flexible ducts of varying lengths
- > Unified indoor unit range for R-32 and R-410A
- > Possibility to change ESP via wired remote control allows optimisation of the supply air volume
- > Discretely concealed in the ceiling: only the suction and discharge grilles are visible
- NEW** > Multi zoning kit allows multiple individually-controlled climate zones to be served by one indoor unit



Indoor units

Efficiency data		FBA + RXS		35A + 35L3		50A + 50L		60A + 60L		
Cooling capacity	Nom.	kW		3.40		5.00		5.70		
Heating capacity	Nom.	kW		4.00		5.50		7.00		
Power input	Cooling	Nom.	kW	0.85		1.42		1.65		
	Heating	Nom.	kW	1.00		1.44		1.89		
Seasonal efficiency (according to EN14825)	Cooling	Energy efficiency class		A++		A++		A+		
		Pdesign	kW	3.40		5.00		5.70		
		SEER		6.17		6.21		5.86		
	Heating (Average climate)	Annual energy consumption		kWh	193		282		340	
		Energy efficiency class			A+		A+		A+	
		Pdesign	kW	2.90		4.40		4.60		
Nominal efficiency	EER	COP		4.02		3.83		3.71		
		Annual energy consumption		kWh	426		710		826	
	Energy labeling Directive	Cooling/Heating				A/A				

Indoor unit		FBA		35A		50A		60A		
Dimensions	Unit	HeightxWidthxDepth		mm		245x700x800		245x1,000x800		
Weight	Unit	kg		28.0				35.0		
Air filter	Type	Resin net								
Fan	Air flow rate	Cooling	Low/Medium/High	m³/min		10.5/12.5 /15.0		12.5/15.0/18.0		
		Heating	Low/Medium/High	m³/min		10.5/12.5 /15.0		12.5/15.0/18.0		
	External static pressure	Nom./High	Pa		30/150					
Sound power level	Cooling	dBA		60				56		
Sound pressure level	Cooling	Low/High	dBA		29.0/35.0				25.0/30.0	
	Heating	Low/High	dBA		29.0/37.0				25.0/31.0	
Control systems	Infrared remote control				BRC4C65 / BRC4C66					
	Wired remote control				BRC1H51 / BRC1E53A / BRC1E53B / BRC1E53C / BRC1D52					
Power supply	Phase/Frequency/Voltage		Hz/V		1~/50/60/220-240/220					

Outdoor unit		RXS		35L3		50L		60L		
Dimensions	Unit	HeightxWidthxDepth		mm		550x765x285		735x825x300		
Weight	Unit	kg		34		47		48		
Sound power level	Cooling	dBA		61		62		62		
	Heating	dBA		61		62		62		
Sound pressure level	Cooling	Low/High	dBA		-/48		44/48		46/49	
	Heating	Low/High	dBA		-/48		45/48		46/49	
Operation range	Cooling	Ambient	Min.~Max.	°CDB		-10~46				
	Heating	Ambient	Min.~Max.	°CWB		-15~18				
Refrigerant	Type					R-410A				
	GWP					2,087.5				
Piping connections	Charge	kg/TCO2Eq		1.2/2.5		1.7/3.5		1.5/3.1		
	Liquid	OD	mm				6.35			
Piping connections	Gas	OD	mm		9.5		12.7			
	Piping length	OU - IU	Max.	m		20		30		
	System	Chargeless	m		10		-			
	Additional refrigerant charge	kg/m		0.02 (for piping length exceeding 10m)		0.020 (for piping length exceeding 10m)				
Power supply	Level difference	IU - OU	Max.	m		15		20.0		
	Phase/Frequency/Voltage	Hz/V		1~/50/220-240		1~/50/220-240		1~/50/220-230-240		
Current - 50Hz	Maximum fuse amps (MFA)		A		-		-			

Concealed ceiling unit with high ESP

ESP up to 200, ideal for large sized spaces

- › Unified range for R-32 and R-410A
- › High external static pressure up to 200Pa facilitates extensive duct and grille network
- › Possibility to change ESP via wired remote control allows optimisation of the supply air volume
- › Discretely concealed in the ceiling: only the suction and discharge grilles are visible
- › Reduced energy consumption thanks to specially developed DC fan motor
- › No optional adapter needed for DIII-connection, link your unit into the wider building management system.
- › Flexible installation, as the air suction direction can be altered from rear to bottom suction
- › Standard built-in drain pump with 625mm lift increases flexibility and installation speed



Efficiency data		FDA + RZQG/RZQSG	FDA125A5VEB / RZQG125L9V1B	FDA125A5VEB / RZQG125L8Y1B	FDA125A5VEB / RZQSG125L9V1B	FDA125A5VEB / RZQSG125L8Y1B	
Cooling capacity	Nom.					12.0	
Heating capacity	Nom.					13.5	
Power input	Cooling	Nom.	kW	3.20		3.74	
	Heating	Nom.	kW	3.53		3.85	
Seasonal efficiency (according to EN14825)	Cooling	Energy efficiency class		A+		A	
		Pdesign	kW		12.0		
		SEER		5.81		5.20	
	Heating (Average climate)	Annual energy consumption	kWh		723		808
		Energy efficiency class			A+		A
		Pdesign	kW		12.7		7.60
Nominal efficiency	EER	SCOP/A		4.21		3.90	
		Annual energy consumption	kWh		4,227		2,729
	COP			3.75		3.21	
		Annual energy consumption	kWh		1,600 (0.000)		1,870 (0.000)
Energy labeling Directive	Cooling/Heating			A / A		A / B	

Indoor unit			FDA	125A
Dimensions	Unit	HeightxWidthxDepth	mm	300x1,400x700
Required ceiling void >			mm	350
Weight	Unit		kg	45
Decoration panel	Model			BYBS125DJW1
	Colour			White (10Y9/0.5)
	Dimensions	HeightxWidthxDepth	mm	55x1,500x500
	Weight		kg	6.5
Air filter	Type			Resin net
Fan - Air flow rate	Cooling	High/Low	m ³ /min	39/28
	Heating	High/Low	m ³ /min	39/28
Fan - External static pressure	High/Nom./Maximum available/High		Pa	200/50/-
Sound power level	Cooling		dBA	66
Sound pressure level	Cooling	High/Low	dBA	40/33
	Heating	High/Low	dBA	40/33
Refrigerant	Type			R-32 / R-410A
Control systems	Infrared remote control			BRC4C65
	Wired remote control			BRC1H51 / BRC1E53A / BRC1E53B / BRC1E53C / BRC1D52
Power supply	Phase / Frequency / Voltage		Hz / V	1~ / 50/60 / 220-240/220

Outdoor unit			RZQG/RZQSG	RZQG125L9V1	RZQG125L8Y1	RZQSG125L9V1	RZQSG125L8Y1
Dimensions	Unit	HeightxWidthxDepth	mm	1,430x940x320		990x940x320	
Weight	Unit		kg	95	101	74	82
Sound power level	Cooling		dBA	67		70	
Sound pressure level	Cooling	Nom.	dBA	51		54/-	
	Heating	Nom.	dBA	53		58	
Operation range	Cooling	Ambient	Min.~Max.	°CDB		-15~46	
	Heating	Ambient	Min.~Max.	°CWB		-20~-15.5	
Refrigerant	Type/GWP			R-410A/2,087.5			
	Charge		kg/TCO2Eq	4.0/8.4		2.9/6.1	
Piping connections	Liquid/Gas		mm	9.52/15.9			
	Piping length	OU - IU	Max.	m			
		System	Equivalent	m			
			Chargeless	m			
		Additional refrigerant charge		kg/m	See installation manual		
Power supply	Level difference	IU - OU	Max.	m			
	Phase/Frequency/Voltage		Hz/V	1~/50/220-240	3N~/50/380-415	1~/50/220-240	3N~/50/380-415
Current - 50Hz	Maximum fuse amps (MFA)		A	40	25	32	16

(1) EER/COP according to Eurovent 2012, for use outside EU only

(2) MFA is used to select the circuit breaker and the ground fault circuit interrupter (earth leakage circuit breaker). For more detailed information on each combination, please refer to the electrical data drawing.

Concealed ceiling unit with high ESP

ESP up to 250, ideal for extra large sized spaces

- > High external static pressure up to 250Pa facilitates using flexible ducts of varying lengths
- > Discretely concealed in the ceiling: only the suction and discharge grilles are visible
- > Up to 26.4kW in heating mode



Indoor units

Indoor unit				FDQ	200B	250B
Dimensions	Unit	HeightxWidthxDepth	mm	450x1,400x900		
Required ceiling void >			mm	450		
Weight	Unit		kg	89.0		94.0
Air filter	Type			Resin net		
Fan - Air flow rate	Cooling	Nom.	m ³ /min	69.0		89.0
	Heating	Nom.	m ³ /min	69.0		89.0
Fan - External static pressure	High/Nom./Low		Pa	250/250/250		
Sound power level	Cooling		dBA	81		82
Sound pressure level	Cooling	High	dBA	45.0		47.0
	Heating	Low	dBA	45.0		47.0
Control systems	Wired remote control			BRC1H51 / BRC1E53A / BRC1E53B / BRC1E53C / BRC1D52		
Power supply	Phase / Frequency / Voltage		Hz / V	1~ / 50 / 230		

Concealed ceiling unit

Ideal for residential applications with false ceilings

- › Energy efficient units: up to class A energy labels
- › Medium external static pressure up to 150Pa facilitates using flexible ducts of varying lengths
- › Slim indoor unit (300mm built-in height) suited for narrow ceiling installation
- › Exclusively offered for pair applications
- › Discretely concealed in the ceiling: only the suction and discharge grilles are visible
- › Flexible installation: air suction direction can be altered from rear to bottom suction and choice between free use or connection to optional suction grilles
- › Drain pump kit available as accessory



Efficiency data		ADEQ + ARXS/AZQS		ADEQ71C + ARXS71L		ADEQ100C + AZQS100B8V1		ADEQ125C + AZQS125B8V1		
Cooling capacity	Nom.		kW	6.80		9.50		12.1		
Heating capacity	Nom.		kW	7.50		10.8		13.5		
Power input	Cooling	Nom.	kW	2.55		-		-		
	Heating	Nom.	kW	2.16		-		-		
Seasonal efficiency (according to EN14825)	Cooling	Energy efficiency class		A		A		-		
		Pdesign	kW	6.80		9.50		-		
		SEER		5.30		5.10		-		
	Annual energy consumption		kWh	449		652		-		
	Heating (Average climate)	Energy efficiency class		A		A		-		
		Pdesign	kW	6.00		7.60		-		
SCOP/A			3.80		3.81		-			
Annual energy consumption		kWh	2,210		2,793		-			
Indoor unit		ADEQ		71C		100C		125C		
Dimensions	Unit	HeightxWidthxDepth		mm		245x1,000x800		245x1,400x800		
Weight	Unit			kg		35		46		
Air filter	Type		Resin net							
Fan	Air flow rate	Cooling	Low/Medium/High	m ³ /min	12.5/15.0 /18.0		23.0/26.0 /29.0		23.5/29.0 /34.0	
		Heating	Low/Medium/High	m ³ /min	12.5/15.0 /18.0		23.0/26.0 /29.0		23.5/29.0 /34.0	
	External static pressure	Nom./High	Pa	30/150		40/150		50/150		
Sound power level	Cooling			dBA	56		58		62	
Sound pressure level	Cooling	Low/Nom./High			dBA	25/30/30		30/34/34		32/37/37
	Heating	Low/Nom./High			dBA	25/31/31		30/36/36		32/38/38
Control systems	Infrared remote control		BRC4C65							
	Wired remote control		BRC1D52							
Power supply	Phase/Frequency/Voltage				Hz/V					
				1~/50/220-240						
Outdoor unit		ARXS/AZQS		ARXS71L		AZQS100B8V1		AZQS125B8V1		
Dimensions	Unit	HeightxWidthxDepth		mm		735x825x300		990x940x320		
Weight	Unit			kg		47		72.8		
Sound power level	Cooling			dBA		65		70		
	Heating			dBA		65		71		
Sound pressure level	Cooling	Nom.			dBA	52			54	
	Heating	Nom.			dBA	52		57	58	
Operation range	Cooling	Ambient	Min.~Max.	°CDB	-10~46				-5~46	
	Heating	Ambient	Min.~Max.	°CWB	-15~18				-15~15.5	
Refrigerant	Type		R-410A							
	GWP		2,087.5							
Piping connections	Charge				kg/CO ₂ Eq	1.70/-		2.9/6.1		
	Liquid	OD			mm	9.52		9.52		
	Gas	OD			mm	15.9		15.9		
	Piping length	OU - IU	Max.			m	30		50	
		System	Equivalent			m		70		
			Chargeless			m	10		30	
Power supply	Additional refrigerant charge				kg/m	0.02 (for piping length exceeding 10m)		See installation manual		
	Level difference	IU - OU	Max.			m	20.0		30.0	
Current - 50Hz	Phase/Frequency/Voltage				Hz/V		1~/50/220-230-240			
	Maximum fuse amps (MFA)				A		-			

Concealed ceiling unit

Ideal for medium sized shops with false ceilings

- › Ideal solution for busy retail and business environments and small shops
- › Discretely concealed in the ceiling: only the suction and discharge grilles are visible
- › Exclusively offered for pair applications
- › Air filter removes airborne dust particles to ensure a steady supply of clean air
- › Easy installation and maintenance
- › Double protection drainage system ensures quality



Indoor units

Efficiency data			ABQ + AZQS	140C + 140B8V1	100C + 100BY1	125C + 125BY1	140C + 140BY1
Cooling capacity	Nom.		kW	13.0	9.5	12.1	13.0
Heating capacity	Nom.		kW	15.5	10.8	13.5	15.5
Power input	Cooling	Nom.	kW	4.32	3.63	4.31	4.32
	Heating	Nom.	kW	4.55	3.16	3.96	4.55
Seasonal efficiency (according to EN14825)	Cooling	Energy label		-	B	-	-
		Pdesign	kW	-	9.50	-	-
		SEER		-	4.65	-	-
		Annual energy consumption	kWh	-	716	-	-
	Heating (Average climate)	Energy label		-	A	-	-
		Pdesign	kW	-	6.78	-	-
		SCOP		-	3.80	-	-
		Annual energy consumption	kWh	-	2,498	-	-
Nominal efficiency	EER			3.01	2.62	2.81	3.01
	COP			3.41	3.42	3.41	
	Annual energy consumption	kWh	-	-	1,813	2,153	-
	Energy label	Cooling/Heating		-	D/B	C/B	-

Indoor unit				ABQ	140C	100C	125C	140C
Dimensions	Unit	HeightxWidthxDepth	mm	378x541x1,499	378x541x1,045	378x541x1,299	378x541x1,499	
Weight	Unit		kg	56	44	50	56	
Air filter	Type							
Fan - Air flow rate	Cooling	High/Nom./Low	m ³ /min	48.7/43.9/37.9	22.7/20.5/18.3	40.5/37.4/34.8	48.7/43.9/37.9	
	Heating	High/Nom./Low	m ³ /min	48.7/43.9/37.9	22.7/20.5/18.3	40.5/37.4/34.8	48.7/43.9/37.9	
Fan - External static pressure	High/Nom./Low		Pa	150/122/92	70/57/45	150/128/111	150/122/92	
Sound power level	Cooling		dB(A)	-	60	-	-	
	Heating		dB(A)	-	60	-	-	
Sound pressure level	Cooling	High/Nom./Low	dB(A)	55/53/50	41/38/36	53/52/50	55/53/50	
	Heating	High/Nom./Low	dB(A)	55/53/50	41/38/36	53/52/50	55/53/50	
Control systems	Wired remote control					ARCWB		
Power supply	Phase / Frequency / Voltage		Hz / V			1~ / 50 / 220-240		

Outdoor unit				AZQS	140B8V1	100BY1	125BY1	140BY1
Dimensions	Unit	HeightxWidthxDepth	mm	1,430x940x320		990x940x320		1,430x940x320
Weight	Unit		kg	94.9		82		101
Sound power level	Cooling		dB(A)		70		71	70
Sound pressure level	Cooling	Nom.	dB(A)		53		54	53
	Heating	Nom.	dB(A)	54		57	58	54
Operation range	Night quiet mode	Level 1	dB(A)				49	
	Cooling	Ambient	Min.~Max.	°CDB			-5~46	
Heating	Ambient	Min.~Max.	°CWB				-15~15.5	
Refrigerant	Type/Charge	kg-TCO ² Eq/GWP		R-410A/4.0/8.4/2,087.5		R-410A/2.9/6.1/2,087.5		R-410A/4.0/8.4/2,087.5
Piping connections	Liquid	OD	mm			9.52		
	Gas	OD	mm			15.9		
Piping length	OU - IU	Max.	m			50		
		System	Equivalent	m			70	
	Additional refrigerant charge	Chargeless	m				30	
		Level difference	IU - OU	Max.	m			30.0
Power supply	Phase / Frequency / Voltage		Hz / V	1~ / 50 / 220-240		3N~ / 50 / 380-415		
Current - 50Hz	Maximum fuse amps (MFA)		A	40		16	20	25

(1) EER/COP according to Eurovent 2012, for use outside EU only (2) MFA is used to select the circuit breaker and the ground fault circuit interrupter (earth leakage circuit breaker). For more detailed information on each combination, please refer to the electrical data drawing.



Wall mounted unit

For rooms with no false ceilings nor free floor space

- › Combination with Seasonal Smart ensures best in class quality, highest efficiency and performance
- › Flat, stylish front panel blends easily within any interior décor and is easier to clean
- › Can easily be installed in both new and refurbishment projects
- › Unified indoor unit range for R-32 and R-410A
- › Reduced energy consumption thanks to specially developed DC fan motor
- › The air is comfortably spread up- and downwards thanks to 5 different discharge angles that can be programmed via the remote control
- › Maintenance operations can be performed easily from the front of the unit
- › Flexible to install as the largest casing only weighs 17kg and piping connection can be done at the bottom, left or right of the unit



Indoor units

Efficiency data		FAA + RZQG	71A + 71L9V1	100A + 100L9V1	71A + 71L8Y1	100A + 100L8Y1	
Cooling capacity	Nom.	kW	6.80	9.50	6.80	9.50	
Heating capacity	Nom.	kW	7.50	10.8	7.50	10.8	
Power input	Cooling	Nom. kW	2.00	2.63	2.00	2.63	
	Heating	Nom. kW	2.03	3.00	2.03	3.00	
Seasonal efficiency (according to EN14825)	Cooling	Energy efficiency class	A++				
		Pdesign	kW	6.80	9.50	6.80	9.50
		SEER		6.43	6.11	6.43	6.11
		Annual energy consumption	kWh	371	545	371	545
	Heating (Average climate)	Energy efficiency class	A+				
		Pdesign	kW	6.33	10.2	6.33	10.2
SCOP/A			4.02	4.01	4.02	4.01	
	Annual energy consumption	kWh	2,205	3,562	2,205	3,562	
Nominal efficiency	EER		3.40	3.62	3.40	3.62	
	COP		3.70	3.61	3.70	3.61	
	Annual energy consumption	kWh	1,000	1,315	1,000	1,315	
	Energy labeling Directive	Cooling/Heating	A/A				

Indoor unit		FAA	71A	100A	71A	100A		
Dimensions	Unit HeightxWidthxDepth	mm	290x1,050x238	340x1,200x240	290x1,050x238	340x1,200x240		
Weight	Unit	kg	13.0	17.0	13.0	17.0		
Air filter	Type	-						
Fan	Air flow rate	Cooling	Low/Medium/High	m ³ /min	14.0/16 /18.0	19.0/23 /26.0	14.0/16 /18.0	19.0/23 /26.0
		Heating	Low/Medium/High	m ³ /min	14.0/16.0/18.0	19.0/23.0/26.0	14.0/16.0/18.0	19.0/23.0/26.0
Sound power level	Cooling		dBA	61	65	61	65	
	Heating		dBA	61	65	61	65	
Sound pressure level	Cooling	Low/High	dBA	40/45	41/49	40/45	41/49	
	Heating	Low/High	dBA	40/45	41/49	40/45	41/49	
Control systems	Wired remote control	BRC1H51 / BRC1E53A / BRC1E53B / BRC1E53C / BRC1D52						
Power supply	Phase/Frequency/Voltage	Hz/V	1~/50/220-240					

Outdoor unit		RZQG	71L9V1	100L9V1	71L8Y1	100L8Y1		
Dimensions	Unit HeightxWidthxDepth	mm	990x940x320	1,430x940x320	990x940x320	1,430x940x320		
Weight	Unit	kg	69	95	80	101		
Sound power level	Cooling		dBA	64	66	64	66	
Sound pressure level	Cooling	Nom.	dBA	48	50	48	50	
	Heating	Nom.	dBA	50	52	50	52	
Operation range	Cooling	Ambient	Min.~Max.	°CDB -15~50				
	Heating	Ambient	Min.~Max.	°CWB -20~-15.5				
Refrigerant	Type/GWP	R-410A/2,087.5						
Piping connections	Charge	kg/TCO ₂ Eq	2.9/6.1	4.0/8.4	2.9/6.1	4.0/8.4		
	Liquid/Gas	mm	9.52/15.9					
	Piping length	OU - IU	Max.	m	50	75	50	75
		System	Equivalent	m	70	90	70	90
		Chargeless	m	30				
	Additional refrigerant charge	kg/m	See installation manual					
Level difference	IU - OU	Max.	m	30.0				
Power supply	Phase/Frequency/Voltage	Hz/V	1~/50/220-240		3N~/50/380-415			
Current - 50Hz	Maximum fuse amps (MFA)	A	25	40	16	25		

MFA is used to select the circuit breaker and the ground fault circuit interrupter (earth leakage circuit breaker). For more detailed information on each combination, please refer to the electrical data drawing.

Wall mounted unit

For rooms with no false ceilings nor free floor space

- › Combination with Seasonal Classic ensures good value for money for all types of commercial applications.
- › Flat, stylish front panel blends easily within any interior décor and is easier to clean
- › Can easily be installed in both new and refurbishment projects
- › Unified indoor unit range for R-32 and R-410A



Efficiency data		FAA + RZQSG		71A + 71L3V1		100A + 100L9V1		100A + 100L8Y1		
Cooling capacity	Nom.		kW		6.80				9.50	
Heating capacity	Nom.		kW		7.50				10.8	
Power input	Cooling	Nom.	kW		2.12				3.16	
	Heating	Nom.	kW		2.08				3.17	
Seasonal efficiency (according to EN14825)	Cooling	Energy efficiency class				A+				
		Pdesign	kW		6.80				9.50	
		SEER			6.05				5.61	
			Annual energy consumption	kWh		394			593	
	Heating (Average climate)	Energy efficiency class				A				A+
		Pdesign	kW		6.33				6.81	
		SCOP/A			3.90				4.01	
Annual energy consumption		kWh		2,155				2,378		
Nominal efficiency	EER				3.21				3.01	
	COP				3.61				3.41	
	Annual energy consumption	kWh			1,059				1,580	
	Energy labeling Directive	Cooling/Heating			A/A				B/B	

Indoor unit		FAA		71A		100A		100A	
Dimensions	Unit	HeightxWidthxD	mm	290x1,050x238				340x1,200x240	
Weight	Unit		kg	13.0				17.0	
Air filter	Type								
Fan	Air flow rate	Cooling	Low/Medium/High	m ³ /min	14.0/16 /18.0			19.0/23 /26.0	
		Heating	Low/Medium/High	m ³ /min	14.0/16.0 /18.0			19.0/23.0 /26.0	
Sound power level	Cooling			dBA	61			65	
	Heating			dBA	61			65	
Sound pressure level	Cooling	Low/High		dBA	40/45			41/49	
	Heating	Low/High		dBA	40/45			41/49	
Control systems	Wired remote control			BRC1H51 / BRC1E53A / BRC1E53B / BRC1E53C / BRC1D52					
Power supply	Phase/Frequency/Voltage		Hz/V	1~/50/220-240					

Outdoor unit		RZQSG		71L3V1		100L9V1		100L8Y1		
Dimensions	Unit	HeightxWidthxD	mm	770x900x320				990x940x320		
Weight	Unit		kg	67		72		82		
Sound power level	Cooling			dBA	65	70		69		
Sound pressure level	Cooling	Nom./Silent operation		dBA	49/47			53/-		
	Heating	Nom.		dBA	51			57		
Operation range	Cooling	Ambient	Min.~Max.	°CDB	-15.0~46			-15~-46		
	Heating	Ambient	Min.~Max.	°CWB		-15~-15.5				
Refrigerant	Type/GWP			R-410A/2,087.5						
	Charge		kg/TCO2Eq	2.75/5.7				2.9/6.1		
Piping connections	Liquid/Gas			9.52/15.9						
	Piping length	OU - IU	Max.	m	50					
		System	Equivalent	m	70					
			Chargeless	m	30					
		Additional refrigerant charge		kg/m	See installation manual					
Power supply	Phase/Frequency/Voltage		Hz/V	1~/50/220-240				3N~/50/380-415		
Current - 50Hz	Maximum fuse amps (MFA)		A	20		32		16		

MFA is used to select the circuit breaker and the ground fault circuit interrupter (earth leakage circuit breaker). For more detailed information on each combination, please refer to the electrical data drawing. | Nominal cooling capacities are based on: indoor temperature: 27°CDB, 19°CWB, outdoor temperature: 35°CDB, equivalent refrigerant piping: 5m, level difference: 0m. Data for standard efficiency series | Nominal heating capacities are based on: indoor temperature: 20°CDB, outdoor temperature: 7°CDB, 6°CWB, equivalent refrigerant piping: 5m, level difference: 0m. Data for standard efficiency series

Ceiling suspended unit

For wide rooms with no false ceilings nor free floor space

- › Combination with Seasonal Smart ensures best in class quality, highest efficiency and performance
- › Ideal for comfortable air flow in wide rooms thanks to Coanda effect: up to 100° discharge angle
- › Even rooms with ceilings up to 3.8m can be heated up or cooled down very easily without capacity loss
- › Can easily be installed in both new and refurbishment projects
- › Unified indoor unit range for R-32 and R-410A
- › Can easily be mounted in corners and narrow spaces, as it only needs 30mm lateral service space
- › Reduced energy consumption thanks to specially developed small tube heat exchanger, DC fan motor and drain pump
- › 5 different fan speeds available for maximum comfort
- › Stylish unit blends easily with any interior. The flaps close entirely when the unit is not operating and there are no air intake grilles visible



Indoor units

Efficiency data			FHA + RZQG	71A + 71L9V1	100A + 100L9V1	125A + 125L9V1	140A + 140L9V1	71A + 71L8Y1	100A + 100L8Y1	125A + 125L8Y1	140A + 140L8Y1	
Cooling capacity	Nom.	kW	6.8	9.5	12.0	13.4	6.8	9.5	12.0	13.4		
Heating capacity	Nom.	kW	7.50	10.80	13.50	15.50	7.50	10.80	13.50	15.50		
Power input	Cooling	Nom. kW	1.78	2.49	3.58	4.05	1.78	2.49	3.58	4.05		
	Heating	Nom. kW	1.82	2.61	3.48	4.27	1.82	2.60	3.48	4.27		
Seasonal efficiency (according to EN14825)	Cooling	Energy efficiency class	A++				A+		A++		A+	
		Pdesign	kW	6.80	9.50	12.00	-	6.80	9.50	12.00	-	
		SEER		6.86	6.11	6.01	-	6.86	6.11	6.01	-	
	Heating (Average climate)	Annual energy consumption	kWh	347	545	699	-	347	545	699	-	
		Energy efficiency class		A+		A++		A+		A++		
		Pdesign	kW	7.60	11.30	14.13	-	7.60	11.30	14.13	-	
Nominal efficiency	EER	SCOP/A		4.32	4.61	4.23	-	4.32	4.61	4.23	-	
		Annual energy consumption	kWh	2,463	3,432	4,677	-	2,463	3,432	4,677	-	
		COP		3.82	3.81	3.35	3.31	3.82	3.81	3.35	3.31	
Annual energy consumption	COP		4.13	4.15	3.89	3.63	4.13	4.15	3.89	3.63		
		Annual energy consumption	kWh	890	1,245	1,790	2,025	890	1,245	1,790	2,025	
		Energy labeling Directive	Cooling/Heating	A/A								

Indoor unit			FHA	71A	100A	125A	140A	71A	100A	125A	140A	
Dimensions	Unit	HeightxWidthxDepth	mm	235x1,270x690		235x1,590x690		235x1,270x690		235x1,590x690		
Weight	Unit		kg	32.0		38.0		32.0		38.0		
Air filter	Type			Resin net								
Fan	Air flow rate	Cooling	Low/Medium/High	m ³ /min	14.0/17.0/20.5	20.0/24.0/28.0	23.0/27.0/31.0	24.0/29.0/34.0	14.0/17.0/20.5	20.0/24.0/28.0	23.0/27.0/31.0	24.0/29.0/34.0
		Heating	Low/Medium/High	m ³ /min	14.0/17.0/20.5	20.0/24.0/28.0	23.0/27.0/31.0	24.0/29.0/34.0	14.0/17.0/20.5	20.0/24.0/28.0	23.0/27.0/31.0	24.0/29.0/34.0
Sound power level	Cooling		dBA	55	60	62	64	55	60	62	64	
Sound pressure level	Cooling	Low/High	dBA	34/38	34/42	37/44	38/46	34/38	34/42	37/44	38/46	
	Heating	Nom./High	dBA	36/38	38/42	41/44	42/46	36/38	38/42	41/44	42/46	
Control systems	Infrared remote control			BRC7GA53 / BRC7GA56								
	Wired remote control			BRC1H51 / BRC1E53A / BRC1E53B / BRC1E53C / BRC1D52								
Power supply	Phase/Frequency/Voltage		Hz/V	1~/50/220-240								

Outdoor unit			RZQG	71L9V1	100L9V1	125L9V1	140L9V1	71L8Y1	100L8Y1	125L8Y1	140L8Y1	
Dimensions	Unit	HeightxWidthxDepth	mm	990x940x320		1,430x940x320		990x940x320		1,430x940x320		
Weight	Unit		kg	69		95		80		101		
Sound power level	Cooling		dBA	64	66	67	69	64	66	67	69	
Sound pressure level	Cooling	Nom.	dBA	48	50	51	52	48	50	51	52	
	Heating	Nom.	dBA	50	52	53	53	50	52	53	53	
Operation range	Cooling	Ambient	Min.~Max.	-15~-50								
	Heating	Ambient	Min.~Max.	-20~-15.5								
Refrigerant	Type/GWP			R-410A/2,087.5								
	Charge		kg/CO ₂ Eq	2.9/6.1		4.0/8.4		2.9/6.1		4.0/8.4		
Piping connections	Liquid/Gas		mm	9.52/15.9								
	Piping length	OU - IU	Max.	m	50		75		50		75	
		System	Equivalent	m	70		90		70		90	
	Chargeless			m	30							
	Additional refrigerant charge			kg/m	See installation manual							
Power supply	Level difference			30.0								
	Phase/Frequency/Voltage		Hz/V	1~/50/220-240				3N~/50/380-415				
Current - 50Hz	Maximum fuse amps (MFA)		A	25		40		16		25		

MFA is used to select the circuit breaker and the ground fault circuit interrupter (earth leakage circuit breaker). For more detailed information on each combination, please refer to the electrical data drawing.

Ceiling suspended unit

For wide rooms with no false ceilings nor free floor space

- › Combination with Seasonal Classic ensures good value for money for all types of commercial applications.
- › Ideal for comfortable air flow in wide rooms thanks to Coanda effect: up to 100° discharge angle
- › Even rooms with ceilings up to 3.8m can be heated up or cooled down very easily without capacity loss
- › Can easily be installed in both new and refurbishment projects
- › Unified indoor unit range for R-32 and R-410A



Efficiency data		FHA + RZQSG	71A + 71L3V1	100A + 100L9V1	125A + 125L9V1	140A + 140L9V1	100A + 100L8Y1	125A + 125L8Y1	140A + 140LY1	
Cooling capacity	Nom.	kW	6.8	9.5	12.0	13.4	9.5	12.0	13.4	
Heating capacity	Nom.	kW	7.50	10.80	13.50	15.50	10.80	13.50	15.50	
Power input	Cooling	Nom.	kW	1.97	2.96	4.15	4.45	2.96	4.45	
	Heating	Nom.	kW	1.88	2.99	3.73	4.54	2.99	4.54	
Seasonal efficiency (according to EN14825)	Cooling	Energy efficiency class	A+		-	-	A+		-	
		Pdesign	kW	6.80	9.50	12.00	-	9.50	12.00	-
		SEER	5.61		-	-	5.61		-	
	Heating (Average climate)	Annual energy consumption	kWh	425	593	749	-	593	749	-
		Energy efficiency class	A		A+	-	A	A+	-	
		Pdesign	kW	7.60		-	-	7.60		-
		SCOP/A	3.90		3.91	4.01	-	3.91	4.01	-
Nominal efficiency	Annual energy consumption	kWh	2,727	2,722	2,654	-	2,722	2,654	-	
	EER	3.46		3.21	2.89	3.01	3.21	2.89	3.01	
	COP	4.00		3.61	3.62	3.41	3.61	3.62	3.41	
Annual energy consumption	kWh		983	1,480	2,075	2,225	1,480	2,075	2,225	
	Energy labeling Directive	Cooling/Heating	A/A		C/A	B/B	A/A	C/A	B/B	

Indoor unit		FHA	71A	100A	125A	140A	100A	125A	140A		
Dimensions	Unit HeightxWidthxDepth	mm	235x1,270x690		235x1,590x690						
Weight	Unit	kg	32.0	38.0							
Air filter	Type	Resin net									
Fan	Air flow rate	Cooling	Low/Medium/High	m ³ /min	14.0/17.0 /20.5	20.0/24.0/28.0	23.0/27.0 /31.0	24.0/29.0 /34.0	20.0/24.0/28.0	23.0/27.0 /31.0	24.0/29.0 /34.0
	Heating	Low/Medium/High	m ³ /min	14.0/17.0 /20.5	20.0/24.0/28.0	23.0/27.0 /31.0	24.0/29.0 /34.0	20.0/24.0/28.0	23.0/27.0 /31.0	24.0/29.0 /34.0	
Sound power level	Cooling	dBA	55	60	62	64	60	62	64		
Sound pressure level	Cooling	Low/High	dBA	34/38	34/42	37/44	38/46	34/42	37/44	38/46	
	Heating	Nom./High	dBA	36/38	38/42	41/44	42/46	38/42	41/44	42/46	
Control systems	Infrared remote control	BRC7GA53 / BRC7GA56									
	Wired remote control	BRC1H51 / BRC1E53A / BRC1E53B / BRC1E53C / BRC1D52									
Power supply	Phase/Frequency/Voltage	Hz/V	1~/50/220-240								

Outdoor unit		RZQSG	71L3V1	100L9V1	125L9V1	140L9V1	100L8Y1	125L8Y1	140LY1
Dimensions	Unit HeightxWidthxDepth	mm	770x900x320	990x940x320		1,430x940x320	990x940x320		
Weight	Unit	kg	67	72	74	95	82		101
Sound power level	Cooling	dBA	65	70		69	70		69
Sound pressure level	Cooling	Nom./Silent operation	dBA	49/47	53/-	54/-	53/-	54/-	53/-
	Heating	Nom.	dBA	51	57	58	54	57	58
Operation range	Cooling	Ambient	Min.~Max.	°CDB		-15~-46			
	Heating	Ambient	Min.~Max.	°CWB		-15~-15.5			
Refrigerant	Type/GWP	R-410A/2,087.5							
	Charge	kg/TCO2Eq	2.75/5.7	2.9/6.1		4.0/8.4	2.9/6.1		4.0/8.4
Piping connections	Liquid/Gas	mm	9.52/15.9						
	Piping length	OU - IU	Max.	m					
		System	Equivalent	m					
		Chargeless	m						
	Additional refrigerant charge	kg/m	See installation manual						
Power supply	Level difference	IU - OU	Max.	m		30.0			
	Phase/Frequency/Voltage	Hz/V	1~/50/220-240				3N~/50/380-415		
Current - 50Hz	Maximum fuse amps (MFA)	A	20	32		-	16		20

MFA is used to select the circuit breaker and the ground fault circuit interrupter (earth leakage circuit breaker). For more detailed information on each combination, please refer to the electrical data drawing. | Nominal cooling capacities are based on: indoor temperature: 27°CDB, 19°CWB, outdoor temperature: 35°CDB, equivalent refrigerant piping: 5m, level difference: 0m. Data for standard efficiency series | Nominal heating capacities are based on: indoor temperature: 20°CDB, outdoor temperature: 7°CDB, 6°CWB, equivalent refrigerant piping: 5m, level difference: 0m. Data for standard efficiency series

Ceiling suspended unit

For wide rooms with no false ceilings nor free floor space

- › Combination with split outdoor units is ideal for small retail, offices or residential applications
- › Ideal for comfortable air flow in wide rooms thanks to Coanda effect: up to 100° discharge angle
- › Even rooms with ceilings up to 3.8m can be heated up or cooled down very easily without capacity loss
- › Can easily be installed in both new and refurbishment projects
- › Unified indoor unit range for R-32 and R-410A



Indoor units

Efficiency data			FHA + RXS	35A + 35L3	50A + 50L	60A + 60L
Cooling capacity	Nom.		kW	3.40	5.00	5.70
Heating capacity	Nom.		kW	4.00	6.00	7.20
Power input	Cooling	Nom.	kW	0.92	1.53	1.72
	Heating	Nom.	kW	0.98	1.79	2.17
Seasonal efficiency (according to EN14825)	Cooling	Energy efficiency class		A++	A+	
		Pdesign	kW	3.40	5.00	5.70
		SEER		6.18	5.87	6.02
		Annual energy consumption	kWh	193	298	332
	Heating (Average climate)	Energy efficiency class		A+	A	
		Pdesign	kW	3.10	4.35	4.71
		SCOP/A		4.43	3.86	3.87
		Annual energy consumption	kWh	981	1,578	1,705
Nominal efficiency	EER			3.70	3.27	3.31
	COP			4.08	3.35	3.32
	Annual energy consumption	kWh		459	765	861
	Energy labeling Directive	Cooling/Heating		A/A		A/C

Indoor unit			FHA	35A	50A	60A	
Dimensions	Unit	HeightxWidthxDepth	mm	235x960x690	235x960x690	235x1,270x690	
Weight	Unit		kg	24.0	25.0	31.0	
Air filter	Type			Resin net			
Fan	Air flow rate	Cooling	Low/Medium/High	m ³ /min	10.0/11.5 /14.0	10.0/12.0 /15.0	11.5/15.0 /19.5
		Heating	Low/Medium/High	m ³ /min	10.0/11.5 /14.0	10.0/12.0 /15.0	11.5/15.0 /19.5
Sound power level	Cooling			dBA	53	54	
Sound pressure level	Cooling	Low/High		dBA	31/36	32/37	
	Heating	Nom./High		dBA	34/36	35/37	
Control systems	Infrared remote control			BRC7GA53 / BRC7GA56			
	Wired remote control			BRC1H51 / BRC1E53A / BRC1E53B / BRC1E53C / BRC1D52			
Power supply	Phase/Frequency/Voltage		Hz/V	1~/50/220-240			

Outdoor unit			RXS	35L3	50L	60L	
Dimensions	Unit	HeightxWidthxDepth	mm	550x765x285	735x825x300		
Weight	Unit		kg	34	47	48	
Sound power level	Cooling			dBA	61	62	
	Heating			dBA	61	62	
Sound pressure level	Cooling	Low/High		dBA	-/48	44/48	
	Heating	Low/High		dBA	-/48	45/48	
Operation range	Cooling	Ambient	Min.~Max.	°CDB	-10~46		
	Heating	Ambient	Min.~Max.	°CWB	-15~18		
Refrigerant	Type				R-410A		
	Charge			kg/TCO2Eq	2,087.5	1.7/3.5	
Piping connections	Liquid	OD		mm	6.35		
	Gas	OD		mm	9.5	12.7	
	Piping length	OU - IU	Max.		m	20	
		System	Chargeless		m	10	
	Additional refrigerant charge			kg/m	0.02 (for piping length exceeding 10m)		
	Level difference	IU - OU	Max.		m	15	
Power supply	Phase/Frequency/Voltage		Hz/V	1~/50/220-240			
Current - 50Hz	Maximum fuse amps (MFA)		A	-			

Ceiling suspended unit

For wide rooms with no false ceilings nor free floor space

- › Ideal solution for commercial spaces with no or narrow false ceilings
- › Exclusively offered for pair applications
- › Can easily be installed in both new and refurbishment projects
- › Air filter removes airborne dust particles to ensure a steady supply of clean air
- › Decrease of temperature variation by automatic fan speed selection or freely selectable 3-step fan speed.
- › Easy installation and maintenance



Efficiency data			AHQ + AZQS	71C + 71BV1	100C + 100B8V1	125C + 125B8V1	140C + 140B8V1	100C + 100BY1	125C + 125BY1	140C + 140BY1	
Cooling capacity	Nom.	kW	6.8	9.5	12.1	13.0	9.5	12.1	13.0		
Heating capacity	Nom.	kW	7.5	10.8	13.5	15.5	10.8	13.5	15.5		
Power input	Cooling	Nom.	2.24	3.62	4.60	4.32	3.62	4.60	4.32		
	Heating	Nom.	2.46	3.17	3.74	4.55	3.17	3.74	4.55		
Seasonal efficiency (according to EN14825)	Cooling	Energy label		B		-		B		-	
		Pdesign	kW	6.80	9.50	-	-	9.50	-	-	
		SEER		4.65	4.60	-	-	4.60	-	-	
	Heating (Average climate)	Annual energy consumption	kWh	511.85	723	-	-	723	-	-	
		Energy label			A		-		A		-
		Pdesign	kW	6.33	7.60	-	-	7.60	-	-	
Nominal efficiency	EER		3.03	2.62	2.63	3.01	2.62	2.63	3.01		
		COP	3.05	3.41	3.61	3.41	3.61	3.41			
	Annual energy consumption	kWh	1,120	1,810	2,300	-	1,810	2,300	-		
Energy label	Cooling/Heating		B/D	D/B	D/A	-	D/B	D/A	-		

Indoor unit			AHQ	71C	100C	125C	140C	100C	125C	140C
Dimensions	Unit	HeightxWidthxDepth	mm	260x1,320x634	260x1,538x634	260x1,786x634	285x1,902x680	260x1,538x634	260x1,786x634	285x1,902x680
Weight	Unit		kg	38	45	54	70	45	54	70
Air filter	Type			Removable / washable						
Fan - Air flow rate	Cooling	High/Nom./Low	m ³ /min	23.8/21.3/18.9	31.1/27.8/24.8	34.4/30.6/27.2	43.9/39.1/28.3	31.1/27.8/24.8	34.4/30.6/27.2	43.9/39.1/28.3
	Heating	High/Nom./Low	m ³ /min	23.8/21.3/18.9	31.1/27.8/24.8	34.4/30.6/27.2	43.9/39.1/28.3	31.1/27.8/24.8	34.4/30.6/27.2	43.9/39.1/28.3
Sound power level	Cooling		dBA	59	64	69	70	64	69	70
	Heating		dBA	62	64	69	70	64	69	70
Sound pressure level	Cooling	High/Nom./Low	dBA	49/48/46	52/47/46	52/50/49	56/53/46	52/47/46	52/50/49	56/53/46
	Heating	High/Nom./Low	dBA	49/48/46	52/47/46	52/50/49	56/53/46	52/47/46	52/50/49	56/53/46
Control systems	Infrared remote control			ARCWLA						
	Wired remote control			ARCWB						
Power supply	Phase / Frequency / Voltage		Hz / V	1~ / 50 / 220-240						

Outdoor unit			AZQS	71BV1	100B8V1	125B8V1	140B8V1	100BY1	125BY1	140BY1	
Dimensions	Unit	HeightxWidthxDepth	mm	770x900x320	990x940x320			1,430x940x320	990x940x320		
Weight	Unit		kg	67	72.8	74.3	94.9	82		101	
Sound power level	Cooling		dBA	64	70	71		70	71	70	
Sound pressure level	Cooling	Nom.	dBA	48	53	54		53	54	53	
	Heating	Nom.	dBA	50	57	58		57	58	54	
Operation range	Night quiet mode	Level 1	dBA	43				49			
		Cooling	Ambient	Min.-Max.	°CDB	-5~-46					
Refrigerant	Type/Charge	kg-TCO ² Eq/GWP		R-410A/2.75/5.7/2,087.5	R-410A/2.9/6.1/2,087.5		R-410A/4.0/8.4/2,087.5	R-410A/2.9/6.1/2,087.5		R-410A/4.0/8.4/2,087.5	
		Heating	Ambient	Min.-Max.	°CWB	-15~-15.5					
Piping connections	Liquid	OD	mm	9.52							
	Gas	OD	mm	15.9							
	Piping length	OU - IU	Max.	m	50						
		System	Equivalent	m	70						
Additional refrigerant charge	Chargeless		m	30							
	Level difference	IU - OU	Max.	m	See installation manual						
	Level difference	IU - OU	Max.	m	30.0						
Power supply	Phase / Frequency / Voltage		Hz / V	1~ / 50 / 220-240				3N~ / 50 / 380-415			
Current - 50Hz	Maximum fuse amps (MFA)		A	20	32			16	20		

(1) EER/COP according to Eurovent 2012, for use outside EU only (2) MFA is used to select the circuit breaker and the ground fault circuit interrupter (earth leakage circuit breaker). For more detailed information on each combination, please refer to the electrical data drawing.



4-way blow ceiling suspended unit

Unique Daikin unit for high rooms with no false ceilings nor free floor space

- > Combination with Seasonal Smart ensures best in class quality, highest efficiency and performance
- > Even rooms with ceilings up to 3.5m can be heated up or cooled down very easily without capacity loss
- > Can easily be installed in both new and refurbishment projects
- > Unified range for R-32 and R-410A
- > Individual flap control: flexibility to suit every room layout without changing the location of the unit!
- > Stylish modern casing finished in pure white (RAL9010) and iron grey (RAL7011) blends easily with any interior
- > Optimum comfort guaranteed with automatic air flow adjustment to the required load
- > 5 different discharge angles between 0 and 60° can be programmed via the remote control
- > Standard drain pump with 500mm lift increases flexibility and installation speed



Efficiency data		FUA + RZQG	71A + 71L9V1	100A + 100L9V1	125A + 125L9V1	71A + 71L8Y1	100A + 100L8Y1	125A + 125L8Y1	
Cooling capacity	Nom.	kW	6.80	9.50	12.0	6.80	9.50	12.0	
Heating capacity	Nom.	kW	7.50	10.8	13.5	7.50	10.8	13.5	
Power input	Cooling	Nom. kW	1.68	2.46	3.54	1.68	2.46	3.54	
	Heating	Nom. kW	1.84	2.73	3.95	1.84	2.73	3.95	
Seasonal efficiency (according to EN14825)	Cooling	Energy efficiency class	A++		A+	A++		A+	
		Pdesign	kW	6.80	9.50	12.0	6.80	9.50	12.0
		SEER		6.42	6.11	5.61	6.42	6.11	5.61
		Annual energy consumption	kWh	371	545	749	371	545	749
	Heating (Average climate)	Energy efficiency class	A+						
		Pdesign	kW	7.60	11.3	14.1	7.60	11.3	14.1
	SCOP/A		4.20	4.50	4.44	4.20	4.50	4.44	
	Annual energy consumption	kWh	2,534	3,516	4,456	2,534	3,516	4,456	
Nominal efficiency	EER		4.05	3.86	3.39	4.05	3.86	3.39	
	COP		4.08	3.95	3.42	4.08	3.95	3.42	
	Annual energy consumption	kWh	840	1,230	1,770	840	1,230	1,770	
	Energy labeling Directive	Cooling/Heating	A/A		A/B	A/A		A/B	

Indoor unit		FUA	71A	100A	125A	71A	100A	125A		
Dimensions	Unit	HeightxWidthxDepth	198x950x950							
Weight	Unit	kg	25.0	26.0		25.0	26.0			
Air filter	Type		Resin net							
Fan	Air flow rate	Cooling	Low/Medium/High	m³/min	16.0/19.5 /23.0	20.0/25.5 /31.0	20.5/26.5 /32.5	16.0/19.5 /23.0	20.0/25.5 /31.0	20.5/26.5 /32.5
		Heating	Low/Medium/High	m³/min	16.0/19.5 /23.0	20.0/25.5 /31.0	20.5/26.5 /32.5	16.0/19.5 /23.0	20.0/25.5 /31.0	20.5/26.5 /32.5
Sound power level	Cooling		dBA	59	64	65	59	64	65	
	Heating		dBA	59	64	65	59	64	65	
Sound pressure level	Cooling	Low/High	dBA	35/41	39/46	40/47	35/41	39/46	40/47	
	Heating	Low/High	dBA	35/41	39/46	40/47	35/41	39/46	40/47	
Control systems	Wired remote control		BRC1H51 / BRC1E53A / BRC1E53B / BRC1E53C / BRC1D52							
Power supply	Phase/Frequency/Voltage	Hz/V	1~/ 50/60 / 220-240/220							

Outdoor unit		RZQG	71L9V1	100L9V1	125L9V1	71L8Y1	100L8Y1	125L8Y1		
Dimensions	Unit	HeightxWidthxDepth	990x940x320	1,430x940x320		990x940x320	1,430x940x320			
Weight	Unit	kg	69	95		80	101			
Sound power level	Cooling		dBA	64	66	67	64	66	67	
Sound pressure level	Cooling	Nom.	dBA	48	50	51	48	50	51	
	Heating	Nom.	dBA	50	52	53	50	52	53	
Operation range	Cooling	Ambient	Min.~Max.	-15~-50						
	Heating	Ambient	Min.~Max.	-20~-15.5						
Refrigerant	Type/GWP		R-410A/2,087.5							
	Charge	kg/TCO2Eq	2.9/6.1	4.0/8.4		2.9/6.1	4.0/8.4			
Piping connections	Liquid/Gas		9.52/15.9							
	Piping length	OU - IU	Max.	m	50	75	50	75		
		System	Equivalent	m	70	90	70	90		
		Chargeless	m	30						
		Additional refrigerant charge	kg/m	See installation manual						
	Level difference	IU - OU	Max.	m	30.0					
Power supply	Phase/Frequency/Voltage	Hz/V	1~/50/220-240			3N~/50/380-415				
Current - 50Hz	Maximum fuse amps (MFA)	A	25	40		16	25			

MFA is used to select the circuit breaker and the ground fault circuit interrupter (earth leakage circuit breaker). For more detailed information on each combination, please refer to the electrical data drawing.

4-way blow ceiling suspended unit

Unique Daikin unit for high rooms with no false ceilings nor free floor space

- > Combination with Seasonal Classic ensures good value for money for all types of commercial applications.
- > Even rooms with ceilings up to 3.5m can be heated up or cooled down very easily without capacity loss
- > Can easily be installed in both new and refurbishment projects
- > Unified range for R-32 and R-410A
- > Individual flap control: flexibility to suit every room layout without changing the location of the unit!
- > 5 different discharge angles between 0 and 60° can be programmed via the remote control



Indoor units

Efficiency data		FUA + RZQSG		71A + 71L3V1	100A + 100L9V1	125A + 125L9V1	100A + 100L8Y1	125A + 125L8Y1			
Cooling capacity	Nom.	kW		6.80	9.50	12.0	9.50	12.0			
Heating capacity	Nom.	kW		7.50	10.8	13.5	10.8	13.5			
Power input	Cooling	Nom.	kW	2.12	2.96	4.53	2.96	4.53			
	Heating	Nom.	kW	2.08	2.99	3.95	2.99	3.95			
Seasonal efficiency (according to EN14825)	Cooling	Energy efficiency class		A+		A		A			
		Pdesign	kW	6.80	9.50	12.0	9.50	12.0			
		SEER		5.81	5.61	5.30	5.61	5.30			
			Annual energy consumption	kWh	410	593	793	593	793		
	Heating (Average climate)	Energy efficiency class		A		A		A+		A	
		Pdesign	kW	6.33						7.60	
		SCOP/A		3.90	4.01	3.85	4.01	3.85			
Annual energy consumption		kWh	2,273	2,654	2,764	2,654	2,764				
Nominal efficiency	EER			3.21	2.65	3.21	2.65				
	COP			3.61	3.41	3.61	3.41				
	Annual energy consumption	kWh	1,060	1,480	2,265	1,480	2,265				
	Energy labeling Directive	Cooling/Heating			A/A	D/B	A/A	D/B			

Indoor unit		FUA		71A	100A	125A	100A	125A	
Dimensions	Unit	HeightxWidthxDepth	mm	198x950x950					
Weight	Unit	kg	25.0	26.0					
Air filter	Type	Resin net							
Fan	Air flow rate	Cooling	Low/Medium/High	m³/min	16.0/19.5 /23.0	20.0/25.5 /31.0	20.5/26.5 /32.5	20.0/25.5 /31.0	20.5/26.5 /32.5
		Heating	Low/Medium/High	m³/min	16.0/19.5 /23.0	20.0/25.5 /31.0	20.5/26.5 /32.5	20.0/25.5 /31.0	20.5/26.5 /32.5
Sound power level	Cooling	dBA	59						
	Heating	dBA	59						
Sound pressure level	Cooling	Low/High	dBA	35/41	39/46	40/47	39/46	40/47	
	Heating	Low/High	dBA	35/41	39/46	40/47	39/46	40/47	
Control systems	Wired remote control	BRC1H51 / BRC1E53A / BRC1E53B / BRC1E53C / BRC1D52							
Power supply	Phase/Frequency/Voltage	Hz/V	1~/ 50/60 / 220-240/220						

Outdoor unit		RZQSG		71L3V1	100L9V1	125L9V1	100L8Y1	125L8Y1	
Dimensions	Unit	HeightxWidthxDepth	mm	770x900x320	990x940x320				
Weight	Unit	kg	67	72	74	82			
Sound power level	Cooling	dBA	65						
Sound pressure level	Cooling	Nom./Silent operation	dBA	49/47	53/-	54/-	53/-	54/-	
	Heating	Nom.	dBA	51	57	58	57	58	
Operation range	Cooling	Ambient	Min.~Max.	°CDB -15.0~46					
	Heating	Ambient	Min.~Max.	°CWB -15~15.5					
Refrigerant	Type/GWP	R-410A/2,087.5							
	Charge	kg/TCO2Eq	2.75/5.7	2.9/6.1					
Piping connections	Liquid/Gas	mm	9.52/15.9						
	Piping length	OU -IU	Max.	m 50					
		System	Equivalent	m 70					
		Chargeless	m	30					
Additional refrigerant charge	kg/m	See installation manual							
Level difference	IU - OU	Max.	m 15	30.0					
Power supply	Phase/Frequency/Voltage	Hz/V	1~/50/220-240				3N~/50/380-415		
Current - 50Hz	Maximum fuse amps (MFA)	A	20	32			16		

MFA is used to select the circuit breaker and the ground fault circuit interrupter (earth leakage circuit breaker). For more detailed information on each combination, please refer to the electrical data drawing. | Nominal cooling capacities are based on: indoor temperature: 27°CDB, 19°CWB, outdoor temperature: 35°CDB, equivalent refrigerant piping: 5m, level difference: 0m. Data for standard efficiency series | Nominal heating capacities are based on: indoor temperature: 20°CDB, outdoor temperature: 7°CDB, 6°CWB, equivalent refrigerant piping: 5m, level difference: 0m. Data for standard efficiency series

Floor standing unit

For commercial spaces with high ceilings

Combination with seasonal smart ensures best in class quality, highest efficiency and performance

- › Unified range for R-32 and R-410A
- › Ideal solution for commercial and busy environments
- › Decrease of temperature variation by automatic fan speed selection or freely selectable 3-step fan speed.
- › Improved comfort as a result of better airflow distribution from the vertical out blow which allows manual adjustment of air outlet blades at the top of the unit.
- › Selectable horizontal out blow to better suit the layout of the room (via wired remote controller BRC1E52)
- › No optional adapter needed for DIII-connection, link your unit into the wider building management system.



Efficiency data			FVA + RZQG	71A + 71L9V1	100A + 100L9V1	125A + 125L9V1	140A + 140L9V1	71A + 71L8Y1	100A + 100L8Y1	125A + 125L8Y1	140A + 140LY1	
Cooling capacity	Nom.		kW	6.80	9.50	12.0	13.4	6.80	9.50	12.0	13.4	
Heating capacity	Nom.		kW	7.50	10.8	13.5	15.5	7.50	10.8	13.5	15.5	
Power input	Cooling	Nom.	kW	2.02	2.49	3.74	4.17	2.02	2.49	3.74	4.17	
	Heating	Nom.	kW	2.06	2.61	3.65	4.30	2.06	2.61	3.65	4.30	
Seasonal efficiency (according to EN14825)	Cooling	Energy efficiency class		A++	A+			A++	A+			
		Pdesign	kW	6.80	9.50	12.00		6.80	9.50	12.00		
		SEER		6.23	5.61			6.23	5.61			
		Annual energy consumption	kWh	383	593	749		383	593	749		
	Heating (Average climate)	Energy efficiency class		A+			A			A		
		Pdesign	kW	6.33	11.30			6.33	11.30			
		SCOP/A		4.05	4.20	3.87		4.05	4.20	3.87		
		Annual energy consumption	kWh	2,189	3,767	4,088		2,189	3,767	4,088		
Nominal efficiency	EER		3.37	3.81	3.21		3.37	3.81	3.21			
	COP		3.64	4.14	3.70	3.61	3.64	4.14	3.70	3.61		
	Annual energy consumption	kWh	1,010	1,245	1,870	2,085	1,010	1,245	1,870	2,085		
	Energy labeling Directive	Cooling/Heating		A / A	A / A	A / A	A / A	A / A	A / A	A / A	A / A	

Indoor unit				FVA	71A	100A	125A	140A	71A	100A	125A	140A
Dimensions	Unit	HeightxWidthxDepth	mm	1,850x600x270	1,850x600x350			1,850x600x270	1,850x600x350			
Weight	Unit		kg	39	47			39	47			
Air filter	Type			Resin net								
Fan - Air flow rate	Cooling	High/Low	m³/min	18/14	28/22	28/24	30/26	18/14	28/22	28/24	30/26	
	Heating	High/Low	m³/min	18/14	28/22	28/24	30/26	18/14	28/22	28/24	30/26	
Sound power level	Cooling		dBA	55	62	63	65	55	62	63	65	
	Heating		dBA	55	62	63	65	55	62	63	65	
Sound pressure level	Cooling	High/Low	dBA	43/38	50/44	51/46	53/48	43/38	50/44	51/46	53/48	
	Heating	High/Low	dBA	43/38	50/44	51/46	53/48	43/38	50/44	51/46	53/48	
Refrigerant	Type			R-32 / R-410A								
Control systems	Wired remote control			BRC1H51 / BRC1E53A / BRC1E53B / BRC1E53C / BRC1D52								
Power supply	Phase / Frequency / Voltage		Hz / V	1~ / 50/60 / 220-240/220								

Outdoor unit				RZQG	71L9V1	100L9V1	125L9V1	140L9V1	71L8Y1	100L8Y1	125L8Y1	140LY1
Dimensions	Unit	HeightxWidthxDepth	mm	990x940x320	1,430x940x320			990x940x320	1,430x940x320			
Weight	Unit		kg	69	95			80	101			
Sound power level	Cooling		dBA	64	66	67	69	64	66	67	69	
Sound pressure level	Cooling	Nom.	dBA	48	50	51	52	48	50	51	52	
	Heating	Nom.	dBA	50	52	53		50	52	53		
Operation range	Cooling	Ambient	Min.~Max.	-15~-50								
	Heating	Ambient	Min.~Max.	-20~-15.5								
Refrigerant	Type/GWP			R-410A/2,087.5								
	Charge		kg/CO2Eq	2.9/6.1	4.0/8.4			2.9/6.1	4.0/8.4			
Piping connections	Liquid/Gas		mm	9.52/15.9								
	Piping length	OU - IU	Max.	50	75			50	75			
		System	Equivalent	70	90			70	90			
			Chargeless	m	30							
			Additional refrigerant charge	kg/m	See installation manual							
Power supply	Level difference	IU - OU	Max.	30.0								
	Phase/Frequency/Voltage		Hz/V	1~/50/220-240				3N~/50/380-415				
Current - 50Hz	Maximum fuse amps (MFA)		A	25	40			16	25			

(1) EER/COP according to Eurovent 2012, for use outside EU only

(2) MFA is used to select the circuit breaker and the ground fault circuit interrupter (earth leakage circuit breaker). For more detailed information on each combination, please refer to the electrical data drawing.

Floor standing unit

For commercial spaces with high ceilings

Combination with Seasonal Classic ensures good value for money for all types of commercial applications

- › Unified range for R-32 and R-410A
- › Ideal solution for commercial and busy environments
- › Decrease of temperature variation by automatic fan speed selection or freely selectable 3-step fan speed.
- › Improved comfort as a result of better airflow distribution from the vertical out blow which allows manual adjustment of air outlet blades at the top of the unit.
- › Selectable horizontal out blow to better suit the layout of the room (via wired remote controller BRC1E52)
- › No optional adapter needed for DIII-connection, link your unit into the wider building management system.



Indoor units

Efficiency data			FVA + RZQSG	71A + 71L3V1	100A + 100L9V1	125A + 125L9V1	140A + 140L9V1	100A + 100L8Y1	125A + 25L8Y1	140A + 140LY1
Cooling capacity	Nom.	kW	6.80	9.50	12.0	13.4	9.50	12.0	13.4	15.5
Heating capacity	Nom.	kW	7.50	10.8	13.5	15.5	10.8	13.5	15.5	15.5
Power input	Cooling	Nom.	kW	2.12	2.96	4.27	4.45	2.96	4.27	4.45
	Heating	Nom.	kW	2.08	2.99	3.96	4.54	2.99	3.96	4.54
Seasonal efficiency (according to EN14825)	Cooling	Energy efficiency class		A				A		
		Pdesign	kW	6.80	9.50	12.0	9.50	12.0		
		SEER		5.50			5.50			
	Heating (Average climate)	Annual energy consumption	kWh	433	605	764	605	764		
		Energy efficiency class		A			A+		A	
		Pdesign	kW	6.33	7.60		7.60			
Nominal efficiency	Annual energy consumption	SCOP/A	3.86	4.01	3.85	4.01	3.85			
		Annual energy consumption	kWh	2,297	2,654	2,764	4.02	3.86		
		EER		3.21	3.21	2.81	3.01	3.21	2.81	3.01
Energy labeling Directive	Cooling/Heating	COP		3.61	3.41	3.41	3.61	3.41	3.41	
		Annual energy consumption	kWh	1,060	1,480	2,135	2,225	1,480	2,135	2,225
		Energy labeling Directive		A / A		A / B		A / A		C / B

Indoor unit			FVA	71A	100A	125A	140A	100A	125A	140A
Dimensions	Unit	HeightxWidthxDepth	mm	1,850x600x270	1,850x600x350					
Weight	Unit		kg	39	47					
Air filter	Type			Resin net						
Fan - Air flow rate	Cooling	High/Low	m ³ /min	18/14	28/22	28/24	30/26	28/22	28/24	30/26
	Heating	High/Low	m ³ /min	18/14	28/22	28/24	30/26	28/22	28/24	30/26
Sound power level	Cooling		dB(A)	55	62	63	65	62	63	65
	Heating		dB(A)	55	62	63	65	62	63	65
Sound pressure level	Cooling	High/Low	dB(A)	43/38	50/44	51/46	53/48	50/44	51/46	53/48
	Heating	High/Low	dB(A)	43/38	50/44	51/46	53/48	50/44	51/46	53/48
Refrigerant	Type			R-32 / R-410A						
Control systems	Wired remote control			BRC1H51 / BRC1E53A / BRC1E53B / BRC1E53C / BRC1D52						
Power supply	Phase / Frequency / Voltage	Hz / V		1 ~ / 50/60 / 220-240/220						

Outdoor unit			RZQSG	71L3V1	100L9V1	125L9V1	140L9V1	100L8Y1	125L8Y1	140LY1
Dimensions	Unit	HeightxWidthxDepth	mm	770x900x320	990x940x320		1,430x940x320	990x940x320		1,430x940x320
Weight	Unit		kg	67	72	74	95	82		101
Sound power level	Cooling		dB(A)	65	70		69	70		69
Sound pressure level	Cooling	Nom./Silent operation	dB(A)	49/47	53/-	54/-	53/-	54/-	53/-	53/-
	Heating	Nom.	dB(A)	51	57	58	54	57	58	54
Operation range	Cooling	Ambient	Min.~Max. °CDB	-15.0~46		-15~46				
	Heating	Ambient	Min.~Max. °CWB	-15~15.5						
Refrigerant	Type/GWP			R-410A/2,087.5						
Piping connections	Charge	kg/CO ₂ Eq		2.75/5.7	2.9/6.1	4.0/8.4	2.9/6.1	4.0/8.4		
	Liquid/Gas	mm		9.52/15.9						
Piping length	OU - IU	Max.	m	50						
	System	Equivalent	m	70						
	Chargeless		m	30						
	Additional refrigerant charge	kg/m		See installation manual						
Level difference	IU - OU	Max.	m	15	30.0					
Power supply	Phase/Frequency/Voltage	Hz/V		1~/50/220-240				3N~/50/380-415		
Current - 50Hz	Maximum fuse amps (MFA)	A		20	32	-	16	20		

(1) EER/COP according to Eurovent 2012, for use outside EU only

(2) MFA is used to select the circuit breaker and the ground fault circuit interrupter (earth leakage circuit breaker). For more detailed information on each combination, please refer to the electrical data drawing.



Concealed floor standing unit

Designed to be concealed in walls

Combination with split outdoor units is ideal for small retail, offices or residential applications

- › Unified range for R-32 and R-410A
- › Ideal for installation in offices, hotels and residential applications
- › Blends unobtrusively with any interior design: only the suction and discharge grills are visible
- › Its low height (620 mm) enables the unit to fit perfectly beneath a window
- › Requires very little installation space as the depth is only 200mm
- › High ESP allows flexible installation



Indoor units

Efficiency data			FNA + RXS	25A + 25L3	35A + 35L3	50A + 50L	60A + 60L
Cooling capacity	Nom.		kW	2.60	3.40	5.00	6.00
Heating capacity	Nom.		kW	3.20	4.00	5.80	7.00
Power input	Cooling	Nom.	kW	0.69	1.11	1.49	2.24
	Heating	Nom.	kW	0.80	1.15	1.74	2.25
Seasonal efficiency (according to EN14825)	Cooling	Energy efficiency class		A+			
		Pdesign	kW	2.60	3.40	5.00	6.00
		SEER		5.63	5.65	5.72	5.51
	Heating (Average climate)	Energy efficiency class		A+			
		Pdesign	kW	2.80	2.90	4.00	4.60
		SCOP/A		4.24	4.05	4.09	4.16
Nominal efficiency	Annual energy consumption		kWh	162	211	306	381
		EER		3.77	3.06	3.35	2.68
		COP		4.00	3.48	3.34	3.11
	Annual energy consumption		kWh	345	556	746	1,119
		Energy labeling Directive	Cooling/Heating		A / A	B / B	A / C

Indoor unit			FNA	25A	35A	50A	60A
Dimensions	Unit	HeightxWidthxDepth	mm	620 / 720(2)x750x200		620 / 720(2)x1,150x200	
Weight	Unit		kg	23		30	
Air filter	Type			Resin net			
Fan - Air flow rate	Cooling	High/Low	m³/min	8.7/7.3		16.0/13.5	
	Heating	High/Low	m³/min	8.7/7.3		16.0/13.5	
Fan - External static pressure	High/Nom./Maximum available/High		Pa	48/30/-		49/40/-	
Sound power level	Cooling		dBA	53		56	
Sound pressure level	Cooling	High/Low	dBA	33/28		36/30	
	Heating	High/Low	dBA	33/28		36/30	
Refrigerant	Type			R-32 / R-410A			
Control systems	Infrared remote control			BRC4C65			
	Wired remote control			BRC1H51 / BRC1E53A / BRC1E53B / BRC1E53C / BRC1D52			
Power supply	Phase / Frequency / Voltage		Hz / V	1~ / 50/60 / 220-240/220			

Outdoor unit			RXS	25L3	35L3	50L	60L
Dimensions	Unit	HeightxWidthxDepth	mm	550x765x285		735x825x300	
Weight	Unit		kg	34		47	
Sound power level	Cooling		dBA	59	61	62	
	Heating		dBA	59	61	62	
Sound pressure level	Cooling	Low/High	dBA	-/46	-/48	44/48	
	Heating	Low/High	dBA	-/47	-/48	45/48	
Operation range	Cooling	Ambient	Min.~Max.	°CDB		-10~-46	
	Heating	Ambient	Min.~Max.	°CWB		-15~-18	
Refrigerant	Type			R-410A			
	GWP			2,087.5			
Piping connections	Charge		kg/CO2Eq	1.0/2.1	1.2/2.5	1.7/3.5	1.5/3.1
	Liquid	OD	mm	6.35			
	Gas	OD	mm	9.5		12.7	
	Piping length	OU - IU	Max.	m		30	
	System	Chargeless		m		-	
Additional refrigerant charge			kg/m	0.02 (for piping length exceeding 10m)		0.020 (for piping length exceeding 10m)	
	Level difference	IU - OU	Max.	m		20.0	
Power supply	Phase/Frequency/Voltage		Hz/V	1~/50/220-240		1~/50/220-230-240	
Current - 50Hz	Maximum fuse amps (MFA)		A	-			

(1) EER/COP according to Eurovent 2012, for use outside EU only

(2) Including installation legs (3) MFA is used to select the circuit breaker and the ground fault circuit interrupter (earth leakage circuit breaker). For more detailed information on each combination, please refer to the electrical data drawing.



SKY AIR ALPHA-SERIES



SKY AIR ADVANCE-SERIES



SUPER INVERTER

Outdoor units



A range of industry leading technology outdoor units

Products overview 90
Benefits overview 91

Sky Air pair, twin, triple, double twin applications 92

R-32 BLUEEVOLUTION range 102

RZAG-MV1/MY1	SkyAir Alpha-series	102
RZASG-MV1/MY1	SkyAir Advance-series	103
AZAS-MV1/MY1	SkyAir Active-series	104

R-410A range 105

RZQG-L9V1/L(8)Y1	Seasonal Smart	105
RZQSG-L3/L9V1/LY1	Seasonal Classic	106
AZQS-B8V1/BY1		107
RZQ-C	Super Inverter	108

Multi model and VRV range 109

- > Connect up to 5 different Sky Air units to our multi range
- > Connect up to 9 different Sky Air units to our Sky Air VRV range
- > For more info split en VRV installer catalogue

Pair solution

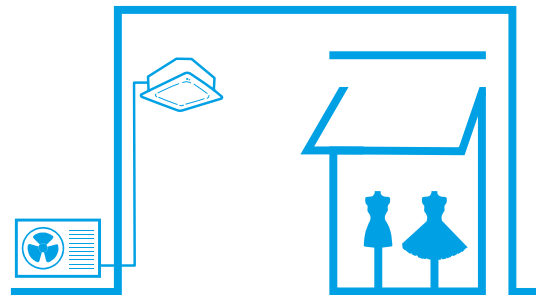

Twin, triple, double twin solution

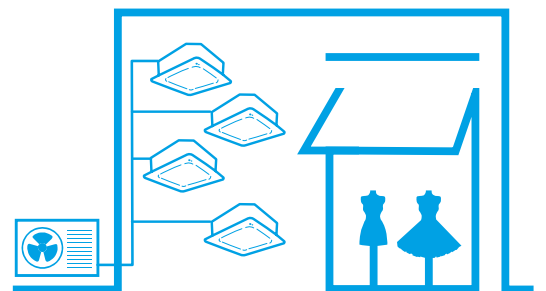

Multi solution

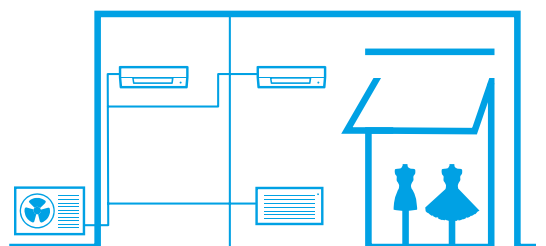

Products overview outdoor units



























BLUEEVOLUTION

Pair, twin, triple & double twin application

R-32

SkyAir A-series

Capacity clas





























System	Type	Model	Product name	PG	71	100	125	140	
Air cooled	Heat pump	SkyAir Alpha-series - Industry leading technology for commercial applications - Dedicated solution for infrastructure cooling - Variable Refrigerant Temperature - Maximum piping length up to 85m - Replacement technology - Extended operation range down to -20°C in both heating and cooling - Pair, twin, triple and double twin application	R-32 	RZAG-MV1	102				
				RZAG-MY1	102				
				RZASG-MV1	103				
				RZASG-MY1	103				
		SkyAir Advance-series - Technology and comfort combined for commercial applications - Very compact and easy to install outdoor units - Maximum piping length up to 50m - Replacement technology - Operation range down to -15°C both cooling and in heating - Pair, twin, triple and double twin application	R-32 	AZAS-MV1	104				
				AZAS-MY1	104				

Pair, twin, triple & double twin application



















R-410A

SkyAir

Capacity class



System	Type	Model	Product name	PG	71	100	125	140	200	250	
Air cooled	Heat pump	Seasonal Smart - Industry leading technology for commercial applications - Dedicated solution for infrastructure cooling - Variable Refrigerant Temperature - Maximum piping length up to 75m - Re-use technology - Extended operation range down to -20°C in heating and -15°C in cooling - Pair, twin, triple and double twin application		RZQG-L9V1	105						
				RZQG-L(8)Y1	105						
		Seasonal Classic - Technology and comfort combined for commercial applications - Maximum piping length up to 50m - Re-use technology - Operation range down to -15°C both cooling and in heating - Pair, twin, triple and double twin application		RZQSG-L3/L9V1	106						
				RZQSG-L(8)Y1	106						
		Standard outdoor unit - Ideal solution for busy environments and small shops - Easy-to-mount outdoor units: roof, terrace or wall - Outdoor units with swing or scroll compressor - Exclusively offered for pair applications		AZQS-B8V1	107						
				AZQS-BY1	107						
		Super Inverter - Packaged system for commercial applications - For large commercial applications - Re-use technology - Pair, twin, triple and double twin applications		RZQ-C	108						

Benefits overview outdoor units

		 SkyAir Alpha-series RZAG-MV1 / MY1	 SkyAir Advance-series RZASG-MV1 / MY1	 SkyAir Active-series AZAS-MV1 / MY1	 RZQG-L9W1/ L18Y1-	 RZQSG-L39V1/L18Y1	 AZQS- B8V1/BY1	 RZQ-C
We care icons	 Seasonal efficiency - Smart use of energy Seasonal efficiency gives a more realistic indication on how efficient air conditioners operate over an entire heating or cooling season.	A ⁺	A ⁺	A	A ⁺	A ⁺	A	•
	 Inverter technology In combination with inverter controlled outdoor units	•	•	•	•	•	•	•
	 Replacement technology Quick and quality system replacement in the most cost effective way	•	•	•	•	•	•	•
Comfort	 Night quiet Lowers the operation sound of the outdoor unit automatically.	•	•	•	•	•		
	 Auto cooling-heating changeover Automatically selects cooling or heating mode to achieve the set temperature.	•	•	•	•	•	•	•
Other functions	 Variable refrigeration temperature The intelligent systems ensures highest energy savings with additional comfort to better suit application requirements.	•			•			
	 Twin/triple/double twin application 2, 3 or 4 indoor units can be connected to only 1 outdoor unit even if they have different capacities. All indoor units operate within the same mode (cooling or heating) from one remote control.	•	•		•	•		•
	 Multi model application Up to 5 indoor units (even different capacities) can be connected to a single outdoor unit. All indoor units can individually be operated within the same mode.							
	 Swing compressor Outdoor units are fitted with a swing compressor, renowned for its low noise and high reliability	•	•	•	•	•	•	•
	 Guaranteed operation down to -20°C Daikin is suitable for all climates, even withstanding severe winter conditions with an operation range down to -20°C.	•			•			
 Infrastructure cooling For high sensible, infrastructure cooling applications, dedicated infrastructure cooling settings and allowing asymmetric combinations enhance the system's reliability.	•			•				

Outdoor Unit

Technical benefit overview **SkyAir** A-series

	 SkyAir Alpha-series	 SkyAir Advance-series	 SkyAir Active-series
Compact single fan casing on the entire range		•	•
Maximum piping length	85 m	50 m	30 m
Pivoting front plate	•	•	•
7 segment display	•	•	•
Increased factory charge	•		
Integrated leak check	•		
Refrigerant bottom plate pass	•		
Specially developed R-32 swing compressor	•	•	•
Refrigerant cooled PCB	•	•	•
Intelligent Tablet controller - Online controller app	•	•	•



The new Sky Air A-series, built for all Sky Air applications

- ✓ Lighter and more compact units for easy installation.
Unique single fan range up to 14 kW



Full range below 1m in height!

- ✓ New replacement technology 
A quicker, easier and more reliable approach when replacing existing systems

› Hepta filtration ensures reliable operation without the need for pipe cleaning



- ✓ Increased piping length up to 85m

- ✓ Widest operation range

› Cooling operation from -20°C to 52°C
› Heating operation down to -20°C

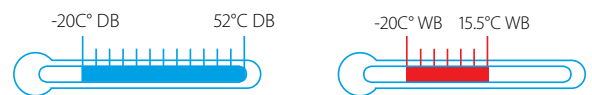

- ✓ Faster installation with up to 40m pre-charged pipe

› Up to 60% of applications can be installed without additional refrigerant charge



- ✓ Redesigned pivoting front plate for easy access to vital system components



✓ **New 7-segment display** to view errors and systems settings



✓ **Guaranteed reliable performance in all weather conditions**

New refrigerant passes

Lower part of the outdoor heat exchanger and drain holes are kept completely open and free of ice allowing ice water to evacuate perfectly, eliminating all risk of ice build-up.

› **Refrigerant cooled PCB's**

Reliable and stable cooling, independent from outdoor conditions



bottom plate refrigerant pass

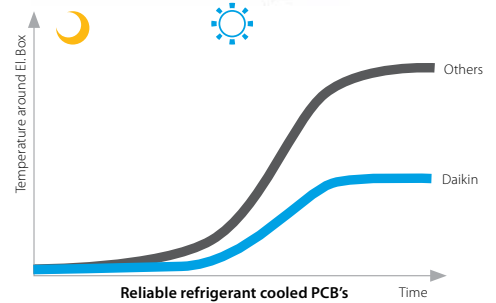

✓ **Integrated leak-check function** reduces on-site checks and improves reliability

Daikin Sky Air A-series uses patented Daikin technology at the heart of the system

3-row heat exchanger

› Unique 3-row heat exchanger to allow compact casing up to 14 kW



Jigsaw curved propeller

› Curved discharge grill and Jigsaw curved propeller for minimal turbulence and optimal airflow



Bottom plate and heat exchanger refrigerant pass

› Drain holes are kept ice free
› Guaranteed operation down to -20°C



Refrigerant cooled PCB

Daikin swing compressor

R-32

Integration of main moving parts into one component

- › No abrasion or friction
- › No refrigerant leakages
- › No temperature rise because of leakage
- › High compressor efficiencies
- › Increased system life span

UNIQUE & PATENTED TECHNOLOGY





Benefits to increase your profit Optimise your business

Less installation time

Tackle more projects in less time thanks to faster installation. It is more profitable than replacing the full system with new piping.

Lower installation costs

Reducing installation costs enables you to offer customers the most cost-effective solution and improve your competitive edge.

Replace non-Daikin systems

NON DAIKIN → **DAIKIN**

It is a trouble-free replacement solution for Daikin systems and for systems made by other manufacturers.

Easy as one-two-three

A simple solution for replacement technology enables you to handle more projects for more customers in less time and offer them the best price! Everybody gains.

The benefits will convince your customer

- ✓ To prevent unexpected breakdown
- ✓ To lower running costs
- ✓ To protect the environment
- ✓ To improve comfort

Your copper pipes will last for multiple generations

- copper pipes used in air conditioning systems tested by Daikin will last over 60 years after installation.

- Japan/China have replaced with VRV Q-series already 10 years ago!

Umeda Center Building, Japan

- original A/C system: 20 years in use
- replacement with VRV Q-series: 2006 - 2009
- capacity up from 1620HP to 2322HP
- SHASE renewal award:

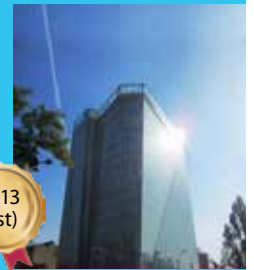

How does it work?

The Daikin low-cost upgrade solution

! Replace indoor units

Contact your local dealer to check compatibility in case you need to keep the indoor units.

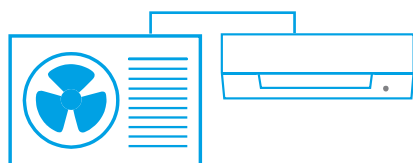

✓ Replace outdoor units

Unique technologies

> Cleaning free piping re-usage thanks to unique hepta filtering for maximum particle reduction

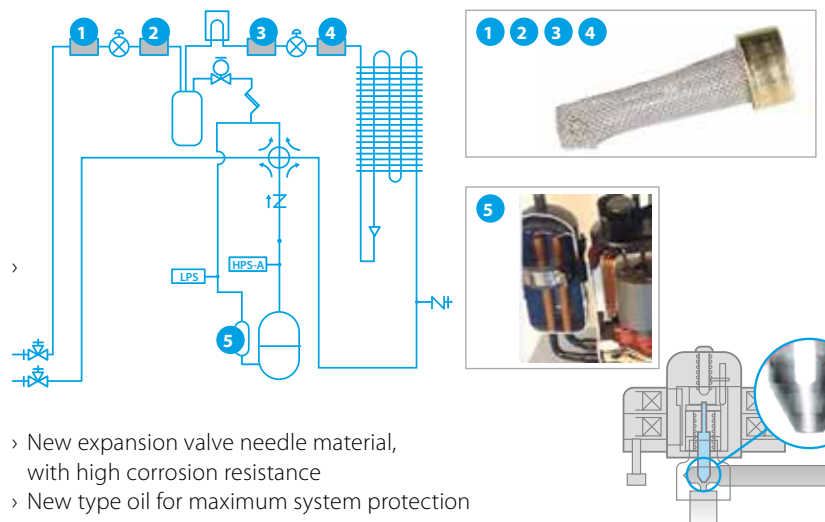

- > New expansion valve needle material, with high corrosion resistance
- > New type oil for maximum system protection

Learn more about Daikin replacement solutions at www.daikin.eu/en_us/knowledge-center/replacement-technology.html

New simplified replacement procedure with Sky Air A-series outdoor units



How does it work?

1 Evaluate if the pipe work can be re-used

- ✓ Check if the piping installation is according to standards, that there no fractures or damages and that liquid and gas pipe have separate insulation
- ✓ Verify pipe thickness

Outside diameter (mm)	Material	Thickness (mm)
6.4	o	0.8
9.5	o	0.8
12.7	o	0.8
15.9	o	1.0
19.1	1/2H	1.0

o: annealed - 1/2H: half hard

- ✓ Verify piping diameter

Sky Air	Liquid	6.4			9.5			12.7	
	Gas	9.5	12.7	15.9	19.1	15.9	19.1		
7.1kW	x	Δ	Δ	✓	x	Δ	x		
10.0-14.0kW	x	x	Δ		o	Δ	Δ		
20.0-25.0kW	Refrigerant pipe size-up required. Please consult the RZQ-C installation manual.								

- ✓ Possible (Standard condition)
- o Possible (With no impact on chargeless length and total length)
- Δ Possible (With impact on chargeless length and total length)
- x Impossible

- ✓ Verify the piping length

RZAG	Liquid pipe (mm)	71	100	125-140
Chargeless (equivalent)	6.4		10 / (15) m	
	9.5		40 / (50) m	
	12.7		15 / (20) m	
Max. total length (equivalent)	6.4		10 / (15) m	
	9.5	55 / (75) m		85 / (100) m
	12.7	25 / (35) m		35 / (45) m

- ✓ Check if any operation history affects the ability to re-use the pipes(systems with a pipe length up to 35m, can always re-use existing pipe work when using a new Sky Air A-series model)

System to be replaced	System condition	Piping length	R-32 Sky Air A-series (RZAG/RZASG/AZAS)
R-22 (mineral oil)	Unit is operating (pump down can be performed)	No restrictions	✓
	Pump down operation impossibility or compressor malfunction	Below 35 m	✓
		Above 35 m	o
R-410A (synthetic oil)	Unit is operating (pump down can be performed)	No restrictions	✓
	Pump down operation impossibility or compressor malfunction	Below 35 m	✓
		Above 35 m	o
R-32 (synthetic oil)	Unit is operating (pump down can be performed)	No restrictions	✓
	Pump down operation impossibility or compressor malfunction	Below 35 m	✓
		Above 35 m	o

- ✓ **Cleaning-free** piping re-use
- o Cleaning of field piping or replacement of field piping is required

- ✓ The Flare connection **MUST** be redone by using the flare nut included with the new outdoor unit

2 Evaluate if the wiring can be re-used

- ✓ Check if the wiring meets current standard and the specificaton of the new unit and that there is no damage or scratches

note: For general installation guidelines and requirements please check the installation manual of the specific outdoor model



The ultimate customer experience

- ✓ Increases air discharge temperature and eliminates cold drafts!
- ✓ Increased customer comfort and reduced energy consumption!

› The system automatically increases its evaporating temperature (T_e) when the gap between the actual indoor temperature (T_{in}) and the setpoint (T_{set}) is becoming smaller

› Possibility to customize the evaporating limits

Weather dependent limitation

- › Two defined outdoor temperatures trigger the changeover of the T_e
- › Between those two trigger values the T_e will change linear

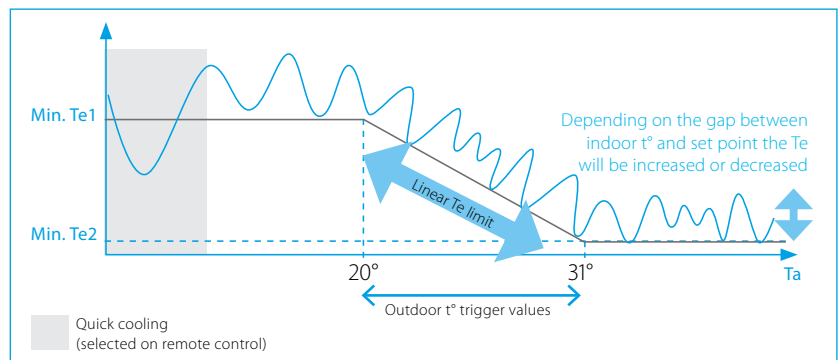

Case study: Clothing shop in the Brussels area

- ✓ Two pair systems are installed in the same zone allowing comparison

	Outdoor	Indoor	Deco panel	Control
System 1 = VRT enabled (Alpha 1)	RZAG125MV1	FCAG125A	BYCQ140D	1 x BRC1E53A
System 2 = Factory settings (Alpha 2)	RZAG125MV1	FCAG125A	BYCQ140D	

- ✓ More energy efficient: up to 20% lower energy consumption

Average energy consumption over 5 months of operation

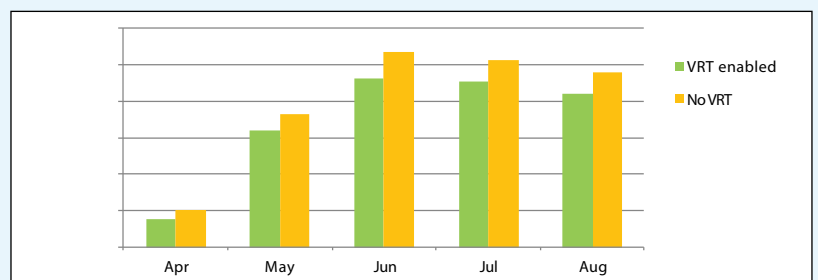

- ✓ Improved comfort: higher discharge temperatures

› More stable and continuous operation

› Average discharge temperature increased with 3~4°C

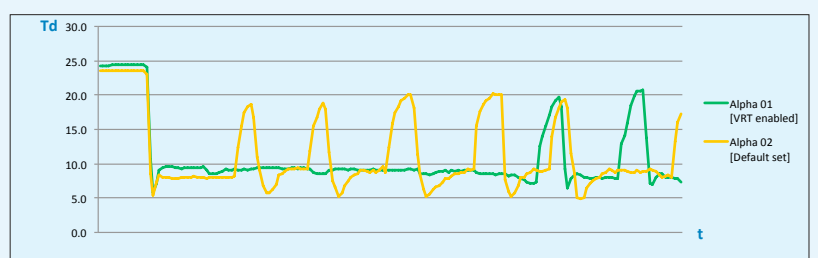



Infrastructure cooling

Daikin is the world leader when it comes to cooling. With over 90 years of innovation and engineering expertise in specialised cooling, Daikin offers a Sky Air solution that is **reliable**, **efficient** and **flexible** to meet the demanding needs of infrastructure cooling environments.



Reliable

Guaranteed system operation:

- › Oversized indoor units boost cooling capacity and prevent freeze-ups on the indoor side
- › Wide operating range envelope: operation range in cooling down to -20°C and up to +52°C

Efficient

Optimum return on investment:

- › Lowers running costs by using highly efficient direct expansion cooling systems
- › Lower running costs compared to other DX systems and water based chillers.
- › Minimises environmental impact with A++ energy labels
- › Reduces mechanical cooling and energy consumption with the free cooling option for single phase systems

Flexible

- › Scalable in capacity
- › Improved infrastructure control and management
- › Lower physical footprint since no floor space is occupied
- › Wide range of indoor units to suit application preferences (ceiling suspended cassettes, wall mounted indoors, concealed ceiling ducted type indoors)

UNIQUE

Dedicated system combinations

Benefits

1. Boost the heat transfer capacity of the indoor system
2. Ability to work with higher evaporation temperatures (Te) avoids downtime and enables continuous operation
3. Official energy labels for indoor and outdoor system combinations provide standardized and reliable performance data

UNIQUE

2-step solution for system selection

Benefits

1. Daikin makes the system selection procedure easy and reliable by providing detailed capacity tables based on extensive testing.
2. Choose the best product combination that meets end-user requirements

UNIQUE

Efficient cooling

Benefits

1. Free cooling: optimum energy efficiency using cold ambient air
2. Widest range of indoor systems with best in class energy efficiency
3. Wide indoor and outdoor operation range, reliable performance even in extreme conditions

UNIQUE

Flexible control

Benefits

1. Optimal backup supported by duty rotation control, automatic backup activation and remote alarms
2. Guaranteed continuous operation from extended compressor limits
3. Controller settings to adapt to specific infrastructure cooling environment conditions
4. Fewer start/stop cycles



Find out more in our infrastructure cooling brochure

Boosted capacity indoor systems

High reliability at lower running costs for infrastructure cooling

Split air conditioning systems for normal comfort cooling applications usually combine indoor systems with matching capacities, or multiple indoor systems with capacities lower than the outdoor system's capacity. This works because the indoor system's cooling capacity is sufficient to handle the higher humidity conditions and varying indoor temperature requirements that are common in a normal living environment.

Applying this design logic to infrastructure cooling environments can lead to risky situations that might compromise overall system reliability and frequent downtimes of 15 minutes. Indoor systems for infrastructure cooling

environments need enhanced capabilities for continuous heat transfer because they work harder to extract energy by cooling dry air. Daikin recommends and offers asymmetric combinations (boosted capacity indoor combinations: e.g. 71 class outdoor + 100 class indoor).

You can now confidently combine indoor systems with higher capacities than the outdoor system. This will boost heat transfer inside the technology or server room environments.

Infrastructure cooling application system solutions

TRADITIONAL SOLUTION

Symmetric indoor-outdoor system combination

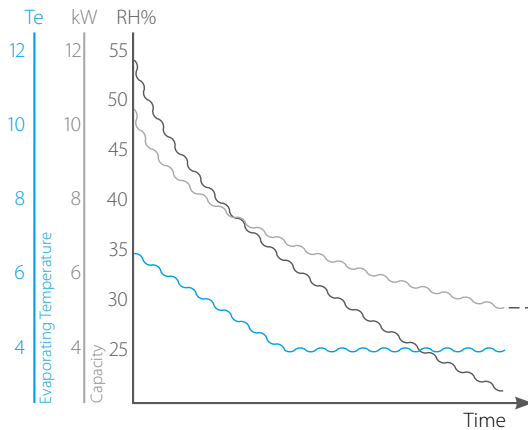

- Relative Humidity: ■ reduces over time
- Capacity: ■ reduced
- Evaporating temp: ■ drops to compensate reduced capacity
- too low Te can lead to freeze-up prevention, causing system downtime

DEDICATED SOLUTION

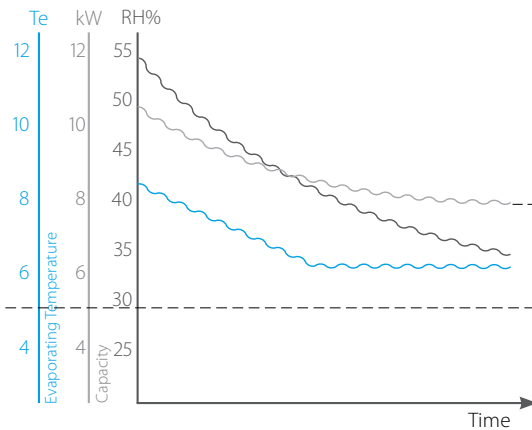

Improved solution

- 👍 Boosted capacity indoors increase the heat transfer capacity at low relative humidity
- 👍 Allows the system to operate with higher Te, guaranteeing continuous operation and reducing unwanted dehumidification

Low humidity + Low ambient environment

Outside temperature Ta	-5 °C
Set-point	22 °C
Humidity	35 %
Indoor wet-bulb temperature	13 °C

EER

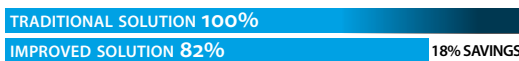

traditional solution

71 class outdoor with 71 class indoor	
Total Capacity (TC)	5.63 kW
Sensible Heat Capacity (SHC)	4.28 kW
Power Input (PI)	2 kW
Co-efficient of Power Input (CPI)	0.39
Corrected PI	0.78 kW
EER*	5,5

dedicated system combination solution

71 class outdoor with 100 class indoor	
Total Capacity (TC)	6,02 kW
Sensible Heat Capacity (SHC)	6,02 kW
Power Input (PI)	2 kW
Co-efficient of Power Input (CPI)	0,45
Corrected PI	0.90 kW
EER*	6,7

18% savings on running cost

Sensible Heat Capacity increases 20-40% with dedicated system combination.

*EER = (SHC/Corrected PI)

2-Step solution for system selection

High reliability for infrastructure cooling

UNIQUE

Select your infrastructure cooling system in 2 steps

No humidity generation in room (eg: Server room)

IT room requires 22°C inside. It will have 7kW of sensible cooling demand, and no latent cooling demand (no humidity generation) throughout the year. Ceiling suspended indoor unit is the customer's preference for the server room.
Indoor temperature = 22°CDB
Sensible cooling demand (SHC) = 7 kW
Latent cooling demand (LC) = 0 kW*
Total cooling demand (TC) = SHC + LC = 7 kW
Outdoor temperature operating range = -15°C ~ +40°C
Most stringent outdoor unit capacity condition = -15°C

SOLUTION

Boosted capacity indoor combination with 10kW outdoor system.

100 class outdoor + **140** class indoor
 Total capacity = 7.48 kW
 Sensible capacity = 7.48 kW
 Power input = 0.42 x 2.49 = 1.04 kW

* If there is no latent cooling demand, look for conditions where TC = SHC, since no more dehumidification will occur and thus the indoor environment will stabilize. When TC > SHC and there is no humidity generation, the indoor humidity will gradually decrease.

STEP 1

Determine requested indoor conditions and required cooling demand (Sensible and Total capacity)

STEP 2

Select the system combination from the given table, where the system's sensible and total capacity meets the cooling demand at the requested indoor and outdoor temperatures.

Some humidity source in room (eg: Laboratory)

Lab requires 22°C inside. It will have 9 kW of sensible cooling demand, and some humidity generation in the room (est. indoor humidity level 42%). Wall mounted indoor unit is the customer's preference for the laboratory.
Indoor temperature = 22°CDB
Indoor Relative Humidity (RH%) = 42%**
Sensible cooling demand (SHC) = 9 kW
Latent cooling demand (LC) = 0.9 kW
Total cooling demand (TC) = SHC + LC = 9.9 kW
Outdoor temperature operating range = -10°C ~ +40°C
Most stringent outdoor unit capacity condition = -10°C

SOLUTION

Boosted capacity indoor combination with 12.5kW outdoor system.

125 class outdoor with twin **71** class indoor
 Total capacity = 10.45 kW
 Sensible capacity = 9.34 kW
 Power input = 0.48 x 3.69 = 1.78 kW

** System capacity at 42%RH (14.2°CWB) can be found by interpolation between 13°CWB (35%) and 15°CWB (48%).

Combination table for boosted capacity indoor systems

Sky Air	Wall mounted	Ceiling suspended unit								Concealed ceiling unit with medium ESP				Concealed ceiling unit	4-way blow ceiling mounted cassette	Floor standing unit	Fully flat cassette			High COP, round flow cassette	Round flow cassette																							
Model	FAA71	FAA100	FHA35	FHA50	FHA60	FHA71	FHA100	FHA125	FHA140	FBA35	FBA50	FBA60	FBA71	FBA100	FBA125	FBA140	FDX135	FDX150	FDX160	FUA71	FUA100	FUA125	FVA71	FVA100	FVA125	FVA140	FFA35	FFA50	FFA60	FCAHG71	FCAHG100	FCAHG125	FCAHG140	FCAG35	FCAG50	FCAG60	FCAG71	FCAG100	FCAG125	FCAG140				
RZAG71 / RZQG71	P	3	2				P			3	2			P			3	2			P			P			3	2		P			3	2					P					
RZAG100 / RZQG100	2	4	3			2				P	4	3	2				P	4	3	2			2			P	4	3	2				P	4	3	2					P			
RZAG125 / RZQG125	2	4	3			2				P	4	3	2				P	4	3	2			2			P	4	3	2				P	4	3	2					P			
RZAG140 / RZQG140	2	4	3			2				P	4	3	2				P	4	3	2			2			P	4	3	2				P	4	3	2					P			

Possible combinations: P = Pair 2 = Twin 3 = Triple 4 = Double Twin

Notes: The capacities in the table are combined capacities (multiple units operating simultaneously) and not individual indoor unit capacities. When combining multiple indoor units, designate the master unit as the unit whose remote controller is equipped with the most functions. Refer to the option list when selecting the correct refnet kit required to install a multi-combination.

Performance characteristics

for boosted capacity indoor combinations

Boosted capacity indoors with 7kW outdoor system

RZAG71MV1/MY1

Indoor	Outdoor temperature [°C DB]																																						
	-15			-10			-5			0			5			10			15			20			25			30			35			40					
	TC	SHC	CPI	TC	SHC	CPI	TC	SHC	CPI	TC	SHC	CPI	TC	SHC	CPI	TC	SHC	CPI	TC	SHC	CPI	TC	SHC	CPI	TC	SHC	CPI	TC	SHC	CPI	TC	SHC	CPI	TC	SHC	CPI	TC	SHC	CPI
RH[%] °CWB °CDB																																							
54.5 11 16	4.81	3.98	0.34	4.81	3.98	0.36	4.81	3.98	0.37	4.81	3.98	0.39	4.81	3.98	0.41	4.81	3.98	0.43	4.81	3.98	0.46	4.81	3.98	0.48	5.90	5.25	0.98	5.85	5.22	1.09	5.80	5.20	1.19	5.76	5.17	1.30	5.76	5.17	1.30
41.8 11 18	4.81	4.67	0.34	4.81	4.67	0.36	4.81	4.67	0.37	4.81	4.67	0.39	4.81	4.67	0.41	4.81	4.67	0.43	4.81	4.67	0.46	4.81	4.67	0.48	5.90	5.90	0.98	5.85	5.85	1.09	5.80	5.80	1.19	5.76	5.76	1.30	5.76	5.76	1.31
57 13 18	6.02	5.05	0.37	6.02	5.05	0.41	6.02	5.05	0.45	6.02	5.05	0.50	6.02	5.05	0.52	6.02	5.05	0.55	6.02	5.05	0.57	6.02	5.05	0.64	7.49	5.89	0.99	7.23	5.75	1.10	6.96	5.61	1.20	6.70	5.47	1.31	6.70	5.47	1.31
31.4 11 20	4.81	4.81	0.34	4.81	4.81	0.36	4.81	4.81	0.37	4.81	4.81	0.39	4.81	4.81	0.41	4.81	4.81	0.43	4.81	4.81	0.46	4.81	4.81	0.48	5.90	5.90	0.98	5.85	5.85	1.09	5.80	5.80	1.19	5.76	5.76	1.30	5.76	5.76	1.31
44.9 13 20	6.02	6.02	0.37	6.02	6.02	0.41	6.02	6.02	0.45	6.02	6.02	0.50	6.02	6.02	0.52	6.02	6.02	0.55	6.02	6.02	0.57	6.02	6.02	0.64	7.49	7.00	0.99	7.23	6.81	1.10	6.96	6.60	1.20	6.70	6.37	1.31	6.70	6.37	1.31
52 14 20	6.62	5.76	0.38	6.62	5.76	0.44	6.62	5.76	0.50	6.62	5.76	0.55	6.62	5.76	0.58	6.62	5.76	0.60	6.62	5.76	0.63	6.62	5.76	0.72	8.15	6.56	0.99	7.74	6.36	1.10	7.34	6.15	1.20	6.93	5.93	1.31	6.93	5.93	1.31
22.9 11 22	4.81	4.81	0.34	4.81	4.81	0.36	4.81	4.81	0.37	4.81	4.81	0.39	4.81	4.81	0.41	4.81	4.81	0.43	4.81	4.81	0.46	4.81	4.81	0.48	5.90	5.90	0.98	5.85	5.85	1.09	5.80	5.80	1.19	5.76	5.76	1.30	5.76	5.76	1.31
34.8 13 22	6.02	6.02	0.37	6.02	6.02	0.41	6.02	6.02	0.45	6.02	6.02	0.50	6.02	6.02	0.52	6.02	6.02	0.55	6.02	6.02	0.57	6.02	6.02	0.64	7.49	7.49	0.99	7.23	7.23	1.10	6.96	6.96	1.20	6.70	6.70	1.31	6.70	6.70	1.31
47.6 15 22	7.22	6.06	0.39	7.22	6.06	0.46	7.22	6.06	0.54	7.22	6.06	0.61	7.22	6.06	0.63	7.22	6.06	0.66	7.22	6.06	0.69	7.22	6.06	0.79	8.41	7.00	1.00	7.99	6.80	1.11	7.58	6.60	1.21	7.16	6.37	1.32	7.16	6.37	1.32
54.3 16 22	7.82	5.71	0.41	7.82	5.71	0.49	7.82	5.71	0.58	7.82	5.71	0.66	7.82	5.71	0.69	7.82	5.71	0.72	7.82	5.71	0.75	7.82	5.71	0.87	8.68	6.54	1.00	8.25	6.35	1.11	7.83	6.14	1.21	7.40	5.92	1.32	7.40	5.92	1.32
21.2 12 24	5.41	5.41	0.36	5.41	5.41	0.38	5.41	5.41	0.41	5.41	5.41	0.44	5.41	5.41	0.46	5.41	5.41	0.49	5.41	5.41	0.52	5.41	5.41	0.56	6.70	6.70	0.99	6.54	6.54	1.10	6.38	6.38	1.20	6.23	6.23	1.31	6.23	6.23	1.31
32.1 14 24	6.62	6.62	0.38	6.62	6.62	0.44	6.62	6.62	0.50	6.62	6.62	0.55	6.62	6.62	0.58	6.62	6.62	0.60	6.62	6.62	0.63	6.62	6.62	0.72	8.15	8.15	0.99	7.74	7.74	1.10	7.34	7.34	1.20	6.93	6.93	1.31	6.93	6.93	1.31
43.8 16 24	7.82	6.57	0.41	7.82	6.57	0.49	7.82	6.57	0.58	7.82	6.57	0.66	7.82	6.57	0.69	7.82	6.57	0.72	7.82	6.57	0.75	7.82	6.57	0.87	8.68	7.45	1.00	8.25	7.26	1.11	7.83	7.04	1.21	7.40	6.82	1.32	7.40	6.82	1.32
50 17 24	8.10	6.08	0.43	8.10	6.08	0.51	8.10	6.08	0.60	8.10	6.08	0.68	8.10	6.08	0.70	8.10	6.08	0.73	8.10	6.08	0.75	8.10	6.08	0.88	8.96	6.99	1.00	8.53	6.80	1.11	8.09	6.59	1.21	7.66	6.37	1.32	7.66	6.37	1.32
21.5 14 27	6.62	6.62	0.38	6.62	6.62	0.44	6.62	6.62	0.50	6.62	6.62	0.55	6.62	6.62	0.58	6.62	6.62	0.60	6.62	6.62	0.63	6.62	6.62	0.72	8.15	8.15	0.99	7.74	7.74	1.10	7.34	7.34	1.20	6.93	6.93	1.31	6.93	6.93	1.31
26.3 15 27	7.22	7.22	0.39	7.22	7.22	0.46	7.22	7.22	0.54	7.22	7.22	0.61	7.22	7.22	0.63	7.22	7.22	0.66	7.22	7.22	0.69	7.22	7.22	0.79	8.41	8.41	1.00	7.99	7.99	1.11	7.58	7.58	1.21	7.16	7.16	1.32	7.16	7.16	1.32
31.3 16 27	7.82	6.41	7.82	6.41	7.82	6.41	7.82	6.41	7.82	6.41	7.82	6.41	7.82	6.41	7.82	6.41	7.82	6.41	7.82	6.41	7.82	6.41	8.68	8.68	1.00	8.25	8.25	1.11	7.83	7.83	1.21	7.40	7.40	1.32	7.40	7.40	1.32		

3D098206A

PAIR	FAA100	FHA100	FBA100	FUA100	FVA100	FCAHG100	FCAG100
Cooling	2.00	1.78	1.89	1.67	2.02	1.66	2.01

TWIN	FHA50 x 2	FBA50 x 2	FDXM50 x 2	FFA50 x 2	FCAG50 x 2
Cooling	2.34	2.02	2.23	2.02	2.04

TRIPLE	FHA35 x 3	FBA35 x 3	FDXM35 x 3	FFA35 x 3	FCAG35 x 3
Cooling	2.39	2.11	2.26	2.07	2.06

Note : blue cells contain preliminary data

Boosted capacity indoors with 10kW outdoor system

RZAG100MV1/MY1

Indoor	Outdoor temperature [°C DB]																																						
	-15			-10			-5			0			5			10			15			20			25			30			35			40					
	TC	SHC	CPI	TC	SHC	CPI	TC	SHC	CPI	TC	SHC	CPI	TC	SHC	CPI	TC	SHC	CPI	TC	SHC	CPI	TC	SHC	CPI	TC	SHC	CPI	TC	SHC	CPI	TC	SHC	CPI	TC	SHC	CPI	TC	SHC	CPI
RH[%] °CWB °CDB																																							
54.5 11 16	6.00	5.63	0.33	6.00	5.63	0.34	6.00	5.63	0.35	6.00	5.63	0.37	6.00	5.63	0.38	6.00	5.63	0.38	6.00	5.63	0.39	6.00	5.63	0.39	8.36	7.11	1.00	7.92	6.83	1.10	7.48	6.53	1.20	7.09	6.28	1.29	7.09	6.28	1.29
41.8 11 18	6.00	6.00	0.33	6.00	6.00	0.34	6.00	6.00	0.35	6.00	6.00	0.37	6.00	6.00	0.38	6.00	6.00	0.38	6.00	6.00	0.39	6.00	6.00	0.39	8.36	7.98	1.00	7.92	7.72	1.10	7.48	7.43	1.20	7.09	7.15	1.29	7.09	7.15	1.29
57 13 18	7.48	6.37	0.42	7.48	6.37	0.44	7.48	6.37	0.45	7.48	6.37	0.46	7.48	6.37	0.46	7.48	6.37	0.46	7.48	6.37	0.45	7.48	6.37	0.46	9.71	7.67	1.00	9.30	7.42	1.11	8.90	7.16	1.21	8.45	6.88	1.30	8.45	6.88	1.30
31.4 11 20	6.00	6.00	0.33	6.00	6.00	0.34	6.00	6.00	0.35	6.00	6.00	0.37	6.00	6.00	0.38	6.00	6.00	0.38	6.00	6.00	0.39	6.00	6.00	0.39	8.36	8.36	1.00	7.92	7.92	1.10	7.48	7.48	1.20	7.09	7.09	1.29	7.09	7.09	1.29
44.9 13 20	7.48	7.25	0.42	7.48	7.25	0.44	7.48	7.25	0.45	7.48	7.25	0.46	7.48	7.25	0.46	7.48	7.25	0.46	7.48	7.25	0.45	7.48	7.25	0.46	9.71	8.53	1.00	9.30	8.28	1.11	8.90	8.01	1.21	8.45	7.74	1.30	8.45	7.74	1.30
52 14 20	8.22	7.18	0.47	8.22	7.18	0.48	8.22	7.18	0.49	8.22	7.18	0.51	8.22	7.18	0.51	8.22	7.18	0.51	8.22	7.18	0.49	8.22	7.18	0.49	10.50	8.45	1.01	10.23	8.31	1.11	9.96	8.17	1.21	9.68	7.94	1.31	9.68	7.94	1.31
22.9 11 22	6.00	6.00	0.33	6.00	6.00	0.34	6.00	6.00	0.35	6.00	6.00	0.37	6.00	6.00	0.38	6.00	6.00	0.38	6.00	6.00	0.39	6.00	6.00	0.39	8.36	8.36	1.00	7.92	7.92	1.10	7.48	7.48	1.20	7.09	7.09	1.29	7.09	7.09	1.29
34.8 13 22	7.48	7.48	0.42	7.48	7.48	0.44	7.48	7.48	0.45	7.48	7.48	0.46	7.48	7.48	0.46	7.48	7.48	0.46	7.48	7.48	0.45	7.48	7.48	0.46	9.71	9.71	1.00	9.30	9.30	1.11	8.90	8.90	1.21	8.45	8.45	1.30	8.45	8.45	1.30
47.6 15 22	8.96	7.82	0.52	8.96	7.82	0.53	8.96	7.82	0.54	8.96	7.82	0.55	8.96	7.82	0.55	8.96	7.82	0.53	8.96	7.82	0.52	8.96	7.82	0.52	11.28	9.19	1.01	10.89	8.96	1.11	10.51	8.72	1.22	10.12	8.48	1.32	10.12	8.48	1.32
54.3 16 22	9.70	7.54	0.56	9.70	7.54	0.58	9.70	7.54	0.59	9.70	7.54	0.60	9.70	7.54	0.59	9.70	7.54	0.59	9.70	7.54	0.55	9.70	7.54	0.56	11.84	8.40	1.0												

Boosted capacity indoors with 12.5kW outdoor system

RZAG125MV1/MY1

Main data table for RZAG125MV1/MY1 with columns for Indoor (RH, CWB, CDB) and Outdoor temperature (15, 10, 5, 0, 5, 10, 15, 20, 25, 30, 35, 40) and sub-columns for TC, SHC, CPI, kW.

Outdoor Unit

3D098208A

PAIR and TWIN cooling capacity tables for RZAG125MV1/MY1 with columns for model (FHA140, FBA140, FVA140, FCAHG140, FCAHG140, FAA71 x 2, FHA71 x 2, FBA71 x 2, FUA71 x 2, FCAHG71 x 2, FCAHG71 x 2, FAA71 x 2, FHA71 x 2, FBA71 x 2, FUA71 x 2) and Cooling capacity values.

TRIPLE and DOUBLE TWIN cooling capacity tables for RZAG125MV1/MY1 with columns for model (FHA50 x 3, FBA50 x 3, FDXM50 x 3, FFA50 x 3, FCAHG50 x 3, FHA35 x 4, FBA35 x 4, FDXM35 x 4, FFA35 x 4, FCAHG35 x 4) and Cooling capacity values.

Note : blue cells contain preliminary data

Combinations with 14kW outdoor system

RZAG140MV1/MY1

Main data table for RZAG140MV1/MY1 with columns for Indoor (RH, CWB, CDB) and Outdoor temperature (15, 10, 5, 0, 5, 10, 15, 20, 25, 30, 35, 40) and sub-columns for TC, SHC, CPI, kW.

3D098209A

PAIR and TWIN cooling capacity tables for RZAG140MV1/MY1 with columns for model and Cooling capacity values.

TRIPLE and DOUBLE TWIN cooling capacity tables for RZAG140MV1/MY1 with columns for model and Cooling capacity values.

Note : blue cells contain preliminary data

Notes

- 1. The ratings shown are net capacities and include a deduction for indoor fan motor heat.
2. The capacities are based on the following conditions: > Outdoor air: 85% RH > Corresponding refrigerant piping length: 5.0 m > Level difference: 0m
3. CPI is a percentage value compared to the rated value of 1.00
4. For infrastructure cooling applications, it is recommended to use remote controller setting 16(26)-2-03
5. The error rate for this value is less than 5% and depends on the indoor unit type
6. The rated power inputs (PI) for each model are listed in the table above

Sky Air Advance-series

Technology and comfort combined for commercial applications

- > High efficiency:
 - Energy labels up to A++ (cooling) /A+ (heating)
 - compressor offers substantial efficiency improvements
- > Very compact and easy to install outdoor units
- > Replace existing systems without having to replace the piping



- > Guarantees operation in both heating and cooling mode down to -15°C
- > With a gas cooled PCB, reliable cooling is guaranteed, as it is not influenced by ambient temperature
- > Maximum piping length up to 50m.



RZASG100-140MV1/MY1

Outdoor Unit

Pair, twin, triple and double twin application

capacity class	FCAG-A						FFA-A			FDXM-F3			FBA-A										
	35	50	60	71	100	125	140	35	50	60	35	50	60	35	50	60	71	100	125	140			
RZASG71MV1				P						2			2						P				
RZASG100MV1	RZASG100MY1	3	2			P				3	2		3	2						P			
RZASG125MV1	RZASG125MY1	4	3	2			P				4	3	2	4	3	2					P		
RZASG140MV1	RZASG140MY1	4	3		2			P	4	3		4	3		4	3					2		P

capacity class	FDA-A	FHA-A						FUA-A			FAA-A		FVA-A				FNA-A						
	125	35	50	60	71	100	125	140	71	100	125	71	100	71	100	125	140	35	50	60			
RZASG71MV1					P							P		P							2		
RZASG100MV1	RZASG100MY1		3	2			P					P		P							3	2	
RZASG125MV1	RZASG125MY1	P	4	3	2			P					P								4	3	2
RZASG140MV1	RZASG140MY1		4	3		2			P	2			2							P	4	3	



RZASG-MV1



RZASG-MY1

More details and final information can be found our my.daikin.eu

Outdoor unit		RZASG	71MV1	100MV1	125MV1	140MV1	100MY1	125MY1	140MY1
Dimensions	Unit HeightxWidthxDepth	mm	770x900x320	990x940x320					
Weight	Unit	kg	60	70		78	70		77
Sound power level	Cooling	dB(A)	65	70	71	73	70	71	73
	Heating	Nom. dB(A)	46	53		54	53		54
Operation range	Cooling Ambient	Min.~Max. °CDB	-15~46						
	Heating Ambient	Min.~Max. °CWB	-15~15.5						
Refrigerant	Type/GWP		R-32/675						
	Charge	kg/CO ₂ Eq	2.45/1.65	2.60/1.76		2.90/1.96	2.60/1.76		2.90/1.96
Piping connections	Liquid/Gas	mm	9.52/15.9						
	Piping length	OU - IU Max.	50						
		System Equivalent	70						
	Chargeless	30							
	Additional refrigerant charge	kg/m	See installation manual						
Power supply	Level difference	IU - OU Max.	30.0						
	Phase/Frequency/Voltage	Hz/V	1~/50/220-240			3~/50/380-415			
Current - 50Hz	Maximum fuse amps (MFA)	A	20	25	32	16	20	16	

Sky Air Active-series

Ideal solution for small shops

- > High efficiency:
 - Energy labels up to A+ (cooling) /A (heating)
 - compressor offers substantial efficiency improvements
- > Very compact and easy to install outdoor units
- > Replace existing systems without having to replace the piping



- > Guarantees operation in both heating mode down to -15°C and in cooling mode down to -5°C
- > With a gas cooled PCB, reliable cooling is guaranteed, as it is not influenced by ambient temperature
- > Maximum piping length up to 30m
- > Exclusively offered in pair applications



AZAS71MV1/MY1

Pair application

Capacity class	FCAG-A				FBA-A				FAA-A			
	71	100	125	140	71	100	125	140	71	100	125	140
AZAS-MV1	P	P	P	P	P	P	P	P	P	P		
AZAS-MY1		P	P	P		P	P	P		P		

More details and final information can be found our my.daikin.eu



AZAS-MV1



AZAS-MY1

Outdoor unit		AZAS		71M2V1B	100M7V1B	125M7V1B	140M7V1B	100M7Y1B	125M7Y1B	140M7Y1B
Dimensions	Unit	HeightxWidthxDepth		mm	770x900x320		990x940x320			
Weight	Unit			kg	60	70		78	77	
Sound power level	Cooling			dBA	65	70	71	73	70	71
	Heating	Nom.		dBA	46	53		54	53	54
Sound pressure level	Heating	Nom.		dBA	47	57				
	Operation range	Cooling	Ambient	Min.~Max.	°CDB	-5~46				
	Heating	Ambient	Min.~Max.	°CWB	-15~15.5					
Refrigerant	Type/GWP				R-32/675					
	Charge			kg/TCO ₂ Eq	2.45/1.65	2.60/1.76	2.90/1.96	2.60/1.76	2.90/1.96	
Piping connections	Liquid/Gas			mm	9.52/15.9					
	Piping length	OU - IU	Max.	m	30					
		System	Equivalent	m	50					
			Chargeless	m	30					
		Additional refrigerant charge			kg/m	See installation manual				
	Level difference	IU - OU	Max.	m	30.0					
Power supply	Phase/Frequency/Voltage		Hz/V	1~/50/220-240				3~/50/380-415		
Current - 50Hz	Maximum fuse amps (MFA)		A	20	25	32	16	20		

Pair, Twin, Triple, double twin

Industry leading technology for commercial applications and technical rooms

- › Top efficiency:
 - energy labels up to A++ in both cooling and heating
 - compressor that offers substantial efficiency improvements
 - control logic that optimises efficiency at the most frequently encountered operating conditions and that optimises the auxiliary modes (when the unit is not active)
 - heat exchangers that optimise the refrigerant flow at the most frequent operating conditions (temperature and load)
 - via improved nominal performances
- › The perfect balance in efficiency and comfort thanks to Variable Refrigerant Temperature: top seasonal efficiency throughout most of the year and quick reaction speed on the hottest days.



- › Suits high sensible, infrastructure cooling applications
- › Replace existing R-22 or R-407C systems without having to replace the piping



RZQG100-125-140L9V1/L(8)Y1

- › Extended operation range down to -20°C in heating and down to -15°C in cooling
- › With a gas cooled PCB reliable cooling is guaranteed as it is not influenced by ambient temperature
- › Maximum piping length up to 75m, minimum piping length is 5m.

Outdoor Unit

Comfort cooling combination table

	FCAHG-G				FCAG-A				FFA-A		FDA-A		FDXM-F3		FBA-A			FHA-A			FAA-A		FUA-A		FNA-A		FVA-A								
capacity class	71	100	125	140	35	50	60	71	100	125	140	35	50	60	71	100	125	140	35	50	60	71	100	125	140	35	50	60	71	100	125	140			
RZQG71L9V1 RZQG71L8Y1					2			P				2				2				P															
RZQG100L9V1 RZQG100L8Y1	P				3	2			P			3	2			3	2			P								P				P			
RZQG125L9V1 RZQG125L8Y1		P			4	3	2			P		4	3	2		P	4	3	2		P							P	4	3	2		P		
RZQG140L9V1 RZQG140L8Y1	2		P		4	3	2				P	4	3	2				P	4	3	2						P	4	3	2			P		

P = application ; 2/3/4 = twin/triple/double twin application

Infrastructure cooling combination table



	FAA-A				FHA-A				FBA-A				FDXM-F3			FUA-A			FVA-A			FFA-A			FCAHG-G				FCAG-A											
capacity class	71	100	35	50	60	71	100	125	140	35	50	60	71	100	125	140	35	50	60	71	100	125	140	35	50	60	71	100	125	140	35	50	60	71	100	125	140			
RZQG71L9V1 RZQG71L8Y1		P	3	2					P								3	2			P																			
RZQG100L9V1 RZQG100L8Y1	2		4	3					P	4	3	2					P	4	3	2									P	4	3	2					P	4	3	2
RZQG125L9V1 RZQG125L8Y1	2		4	3	2				P	4	3	2					P	4	3	2									P	4	3	2					P	4	3	2
RZQG140L9V1 RZQG140L8Y1	2		4	3	2				P	4	3	2					P	4	3	2									P	4	3	2					P	4	3	2

P = Pair, 2 = Twin, 3 = Triple, 4 = Double twin; For more information on infrastructure cooling options refer to infrastructure cooling catalogue.

Outdoor unit				RZQG	71L9V1	100L9V1	125L9V1	140L9V1	71L8Y1	100L8Y1	125L8Y1	140L8Y1
Dimensions	Unit	HeightxWidthxDepth		mm	990x940x320		1,430x940x320		990x940x320		1,430x940x320	
Weight	Unit			kg	69		95		80		101	
Sound power level	Cooling			dB(A)	64		66		64		66	
Sound pressure level	Cooling	Nom.		dB(A)	48		50		48		50	
	Heating	Nom.		dB(A)	50		52		50		52	
	Night quiet mode	Level 1		dB(A)	43		45		43		45	
Operation range	Cooling	Ambient	Min.~Max.	°CDB								
	Heating	Ambient	Min.~Max.	°CWB								
Refrigerant	Type				R-410A							
	Charge			kg	2.9		4.0		2.9		4.0	
				TCO ₂ eq	6.1		8.4		6.1		8.4	
Piping connections	GWP				2,087.5							
	Liquid	OD		mm	9.52							
	Gas	OD		mm	15.9							
	Piping length	OU - IU	Max.		m	50		75		50		75
System		Equivalent Chargeless		m	70		90		70		90	
	Additional refrigerant charge			kg/m	30							
	Level difference	IU - OU	Max.	m	See installation manual							
					30.0							
Power supply	Phase / Frequency / Voltage			Hz / V	1~ / 50 / 220-240				3N~ / 50 / 380-415			
Current - 50Hz	Maximum fuse amps (MFA)			A	25		40		16		25	

(1) MFA is used to select the circuit breaker and the ground fault circuit interrupter (earth leakage circuit breaker). For more detailed information on each combination, please refer to the electrical data drawing.

Pair, Twin, Triple, double twin

Technology and comfort combined for commercial applications

- › Top efficiency:
 - Energy labels up to A++ (cooling) /A+ (heating) for RZQG71/100L9V1 + FCQG71/100F
 - compressor that offers substantial efficiency improvements
 - control logic that optimises efficiency at the most frequently encountered operating condition
- › Replace existing R-22 or R-407C systems without having to replace the piping



- › Guarantees operation in both heating and cooling mode down to -15°C
- › With a gas cooled PCB reliable cooling is guaranteed as it is not influenced by ambient temperature
- › Maximum piping length up to 50m, minimum piping length is 5m.



RZQSG71-100-125L3/9V1

Pair, twin, triple and double twin application

capacity class	FCAHG-G				FCAG-A				FFA-A			FDXM-F3			FBA-A								
	71	100	125	140	35	50	60	71	100	125	140	35	50	60	35	50	60	71	100	125	140		
RZQSG71L3V1	P				2			P				2			2			2			P		
RZQSG100L9V1	RZQSG100L8Y1	P			3	2			P			3	2		3	2		3	2			P	
RZQSG125L9V1	RZQSG125L8Y1		P		4	3	2			P		4	3	2	4	3	2	4	3	2			P
RZQSG140L9V1	RZQSG140LY1	2			P	4	3		2			P	4	3		4	3		4	3	2		P

capacity class	FDA-A	FHA-A				FUA-A			FAA-A		FVA-A				FNA-A					
	125	35	50	60	71	100	125	140	71	100	125	71	100	71	100	125	140	35	50	60
RZQSG71L3V1		2			P				P			P		P				2		
RZQSG100L9V1	RZQSG100L8Y1		3	2			P			P			P		P			3	2	
RZQSG125L9V1	RZQSG125L8Y1	P	4	3	2			P			P					P		4	3	2
RZQSG140L9V1	RZQSG140LY1		4	3		2			P	2			2				P	4	3	

Outdoor unit		RZQSG		71L3V1	100L9V1	125L9V1	140L9V1	100L8Y1	125L8Y1	140LY1	
Dimensions	Unit	HeightxWidthxDepth	mm	770x900x320	990x940x320	1,430x940x320	990x940x320	1,430x940x320	1,430x940x320	1,430x940x320	
Weight	Unit		kg	67	72	74	95	82	82	101	
Sound power level	Cooling		dB(A)	65	70	70	69	70	70	69	
Sound pressure level	Cooling	Nom./Silent operation	dB(A)	49/47	53/-	54/-	53/-	53/-	54/-	53/-	
	Heating	Nom.	dB(A)	51	57	58	54	57	58	54	
	Night quiet mode	Level 1	dB(A)	-	-	-	49	-	-	-	
Operation range	Cooling	Ambient	Min.~Max. °CDB	-15.0~46	-15.0~46	-15.0~46	-15.0~46	-15.0~46	-15.0~46	-15.0~46	
	Heating	Ambient	Min.~Max. °CWB	-15.0~46	-15.0~46	-15.0~46	-15.0~46	-15.0~46	-15.0~46	-15.0~46	
Refrigerant	Type			R-410A							
	Charge		kg	2.75	2.9	4.0	2.9	4.0	4.0		
Piping connections			TCO ₂ eq	5.7	6.1	8.4	6.1	8.4	8.4		
			GWP	2,087.5							
	Liquid	OD	mm	9.52							
	Gas	OD	mm	15.9							
	Piping length	OU - IU	Max.	m	50						
		System	Equivalent	m	70						
		Chargeless		m	30						
	Additional refrigerant charge		kg/m	See installation manual							
	Level difference	IU - OU	Max.	m	15	30.0	30.0	30.0	30.0	30.0	
Power supply	Phase / Frequency / Voltage		Hz / V	1~ / 50 / 220-240				3N~ / 50 / 380-415			
Current - 50Hz	Maximum fuse amps (MFA)		A	20	32	16	20	16	20	20	

(1) MFA is used to select the circuit breaker and the ground fault circuit interrupter (earth leakage circuit breaker). For more detailed information on each combination, please refer to the electrical data drawing.

Outdoor units

Ideal solution for small shops

- › Daikin outdoor units are neat, sturdy and can easily be mounted on a roof or terrace or simply placed against an outside wall
- › With a gas cooled PCB reliable cooling is guaranteed as it is not influenced by ambient temperature
- › Outdoor units are fitted with either a swing or scroll compressor, renowned for low noise and high energy efficiency
- › Exclusively offered for pair applications (capacity from 71 up to 140)
- › Units optimized for seasonal efficiency give an indication on how efficient an air conditioner operates over an entire heating or cooling season.
- › With a gas cooled PCB reliable cooling is guaranteed as it is not influenced by ambient temperature
- › Daikin outdoor units are neat, sturdy and can easily be mounted on a roof or terrace or simply placed against an outside wall
- › Outdoor units are fitted with either a swing or scroll compressor, renowned for low noise and high energy efficiency
- › Exclusively offered for pair applications (capacity from 71 up to 140)
- › Units optimized for seasonal efficiency give an indication on how efficient an air conditioner operates over an entire heating or cooling season.



Outdoor Unit



Pair application

Capacity class	FCAG-A				ADEQ-C				ABQ-C				AHQ-C			
	71	100	125	140	71	100	125	140	71	100	125	140	71	100	125	140
AZQS-B(8)V1	P	P	P	P	combines with ARXS	P	P					P	P	P	P	P
AZQS-BY1		P	P	P						P	P	P		P	P	P

Outdoor unit		ARXS / AZQS			ARXS		AZQS								
Dimensions	Unit	Height	Width	Depth	mm	71L	71BV1	100B8V1	125B8V1	140B8V1	100BY1	125BY1	140BY1		
Weight	Unit				kg	53	67	72.8	74.3	94.9	82		101		
Sound power level	Cooling	Nom.			dBA	-	64	70	71	70		71	70		
					dBA	-	48	53	54	53		54	53		
Sound pressure level	Heating	Nom.			dBA	-	50	57	58	54	57	58	54		
			Night quiet mode	Level 1	dBA	-	43	49							
Operation range	Cooling	Ambient	Min.~Max.	°CDB	+10~46		-5~46								
					Heating	Ambient	Min.~Max.	°CWB	-15~15.5						
Refrigerant	Type	R-410A													
	Charge			kg	-	2.75	2.9	4.0	2.9	4.0					
			TCO ₂ eq	-	5.7	6.1	8.4	6.1	8.4						
Piping connections	GWP		2,087.5												
	Liquid	OD			mm	9.52									
		Gas	OD			mm	15.9								
	Piping length	OU - IU	Max.			m	30	50				50			
				System	Equivalent	m	-	70				40 for combinations with FCQG			
			Chargeless			m	10	30							
Additional refrigerant charge				kg/m	See installation manual										
Level difference		IU - OU	Max.	m	20.0	30.0									
Power supply	Phase / Frequency / Voltage				Hz / V	1~ / 50 / 220-240					3N~ / 50 / 380-415				
Current - 50Hz	Maximum fuse amps (MFA)				A	-	20	32	40	16	20	25			

(1) MFA is used to select the circuit breaker and the ground fault circuit interrupter (earth leakage circuit breaker). For more detailed information on each combination, please refer to the electrical data drawing.

Pair, Twin, Triple, double twin

Packaged system for commercial applications

- > Available as 20 and 25kW
- > Replace existing R-22 or R-407C systems without having to replace the piping



- > Guarantees operation in heating mode down to -15°C
- > Standard night quiet mode
- > Maximum piping length up to 100m
- > Maximum installation height difference up to 30m
- > Wide range of connectable indoor units



Pair, twin, triple and double twin application

capacity class	FCAG-A					FFA-A		FDXM-F3		FBA-A					FHA-A			FDQ-B		FUA-A			FAA-A			FDA-A		FNA-A	
	50	60	71	100	125	50	60	50	60	50	60	71	100	125	50	60	71	100	125	200	250	71	100	125	71	100	125	50	60
RZQ200C	4	3	3	2		4	3	4	3	4	3	3	2		4	3	3	2			P	3	2		3	2		4	3
RZQ250C		4			2		4		4		4			4		2			2		P			2			2		4

Outdoor unit		RZQ	200C	250C
Dimensions	Unit	HeightxWidthxDepth	1,680x930x765	
Weight	Unit	kg	183	184
Sound power level	Cooling	dBA	78	
	Heating	dBA	78	
Sound pressure level	Nom.	dBA	57	
Operation range	Cooling	Ambient	Min.-Max.	°CDB
	Heating	Ambient	Min.-Max.	°CWB
Refrigerant	Type	R-410A		
	Charge	kg	8.3	9.3
		TCO ₂ eq	17.3	19.4
Piping connections	Liquid	OD	9.52	12.7
	Gas	OD	22.20	
	Piping length	OU - IU	Max.	100
	Level difference	IU - OU	Max.	-
Power supply	Phase / Frequency / Voltage		3N~ / 50 / 380-415	
Current - 50Hz	Maximum fuse amps (MFA)		A 20	

(1) MFA is used to select the circuit breaker and the ground fault circuit interrupter (earth leakage circuit breaker). For more detailed information on each combination, please refer to the electrical data drawing.

Multi model applications

- All indoor units can be individually controlled and do not need to be installed in the same room.
- Combine different types of indoor units: wall mounted, floor standing, ceiling suspended, round flow cassette, concealed ceiling.
- Phased installation possible.

MXS /MXM

Installation flexibility

- › A very wide range is available, from 2-port to 5-port units, making all applications possible.
- › Up to 5 indoor units can be connected to 1 multi outdoor unit.
- › Outdoor multi split units are fitted with the Daikin swing compressor, renowned for its low noise and high energy efficiency.
- › The outdoor units are neat and sturdy and can be mounted easily on a roof or terrace or simply placed against an outside wall.



RXYS(C)Q

Installation flexibility

- › Up to 9 indoor units can be connected to 1 VRV outdoor unit
- › Maximum total piping length of 145m offers much more flexibility in the choice of installation position

VRV IV S-series

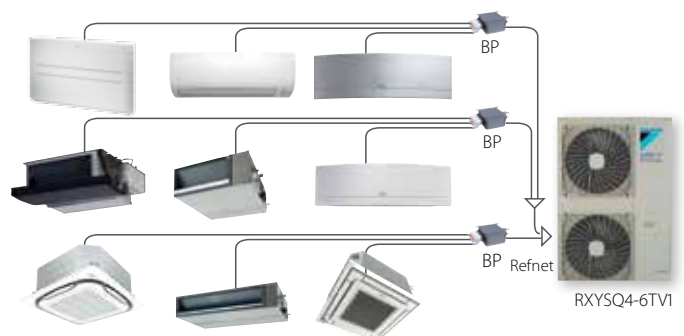
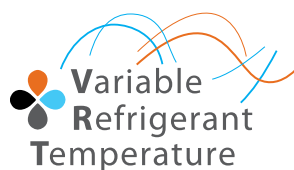

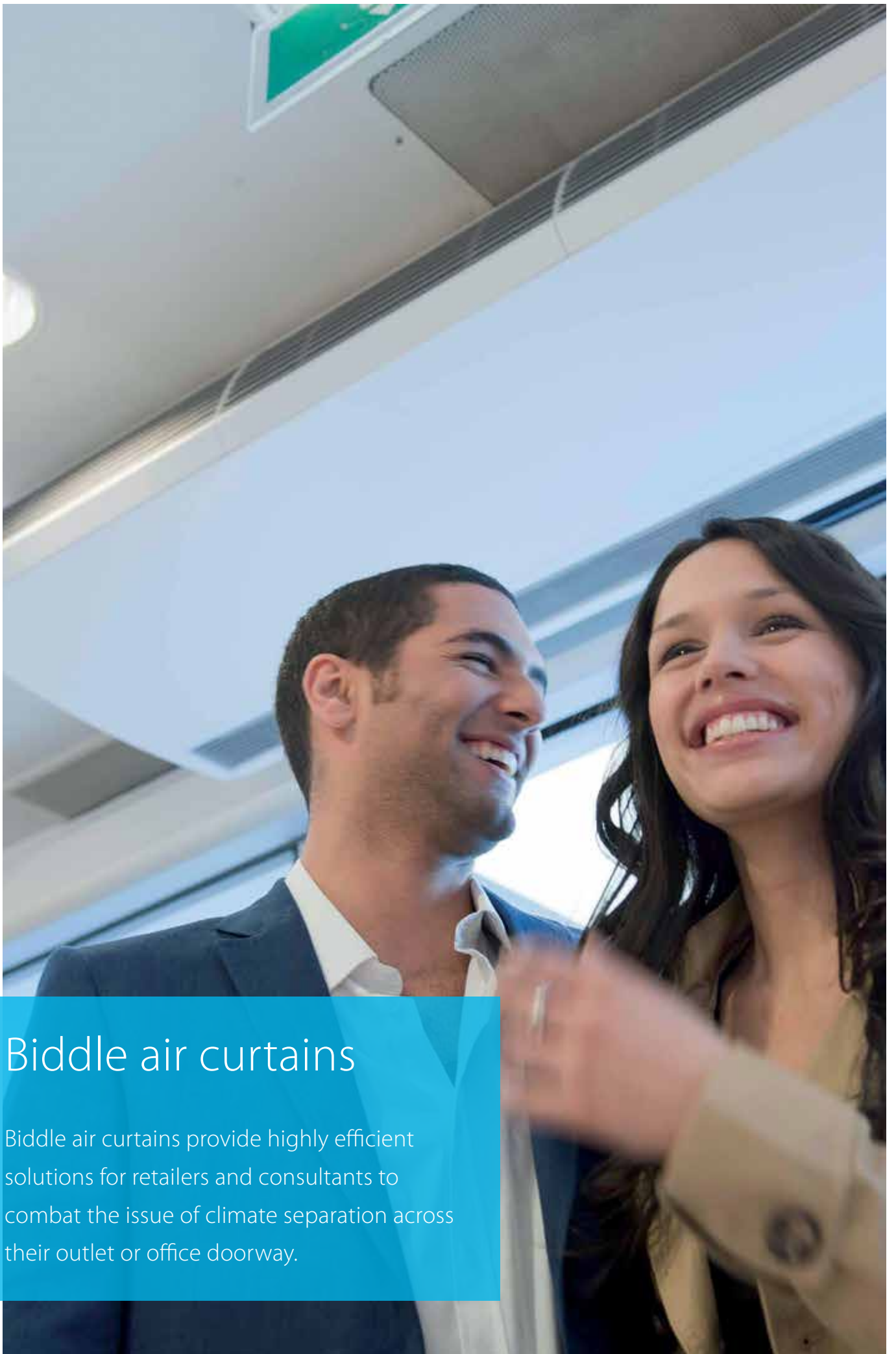



Biddle air curtains

Biddle air curtains provide highly efficient solutions for retailers and consultants to combat the issue of climate separation across their outlet or office doorway.

Outdoor units portfolio for connection to Biddle air curtains

System	Type	Product name	Condensing units	71	100	125	140	200	250
Air cooled	Heat pump	ERQ-AV1 ¹ Condensing Units	- High efficiency - High comfort levels - Easy design and installation			●	●	●	
		ERQ-AW1 ¹ Condensing Units	- Maximize installation flexibility by offering 4 types of control systems				●		●

1) Only use the condensing units in combinations with an air handling unit.

Biddle air curtain portfolio

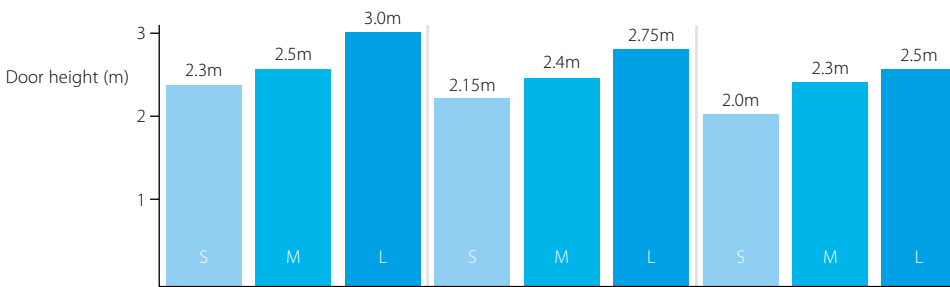



Installation condition

Favourable
ex: covered shopping mall or revolving door entrance

Normal
ex: little direct wind, no opposite open doors, building with ground floor only

Unfavourable
ex: location at a corner or square, multiple floors and/or open stairwell

Type	Product name	Features	
Biddle standard air curtain free hanging	CYQ S/M/L-DK-F	- CYQ - Biddle air curtain for connection to ERQ - Connectable to ERQ heat pump	
Biddle standard air curtain cassette	CYQ S/M/L-DK-C	- Cassette model (C): mounted into a false ceiling leaving only the decoration panel visible - Free-hanging model (F): easy wall mounted installation - Recessed model (R): neatly concealed in the ceiling	
Biddle standard air curtain recessed	CYQ S/M/L-DK-R	- A payback period of less than 1.5 years compared to installing an electric air curtain - Easy and quick to install at reduced costs since no additional water systems, boilers and gas connections are required	

Biddle air curtain nomenclature

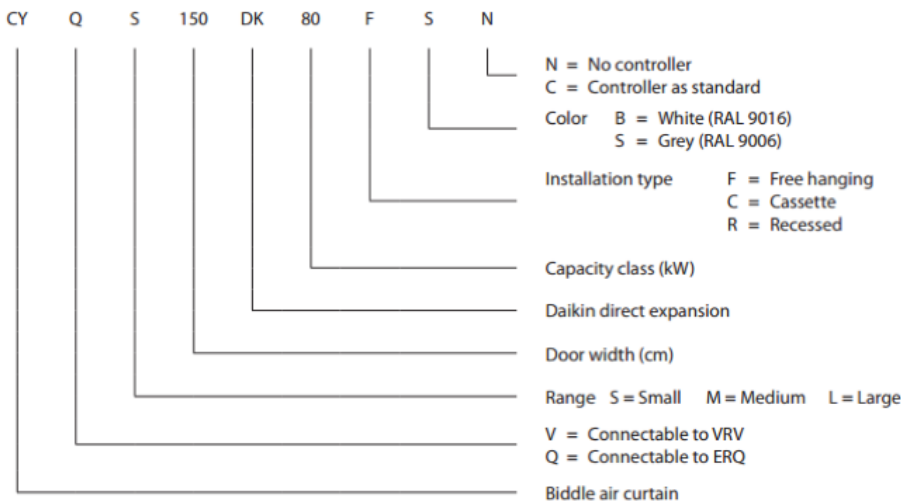

Biddle air curtain for ERQ

- › Connectable to ERQ heat pump
- › ERQ is among the first DX systems suitable for connection to air curtains
- › Free-hanging model (F): easy wall mounted installation
- › Cassette model (C): mounted into a false ceiling leaving only the decoration panel visible
- › Recessed model (R): neatly concealed in the ceiling
- › A payback period of less than 1.5 years compared to installing an electric air curtain
- › Easy and quick to install at reduced costs since no additional water systems, boilers and gas connections are required
- › Maximum energy efficiency stemming from almost zero down flow turbulence, optimised air flow and the application of advanced discharge rectifier technology
- › Around 85% air separation efficiency, greatly reducing both heat loss and required indoor unit heating capacity



CYQM150DK80FSN



CYQM150DK80CSN



CYQM150DK80RSN

Packtime of less than 1.5 years

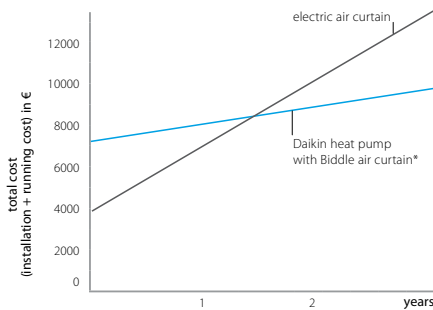

			Small			Medium			
			CYQS150DK80 *BN/*SN	CYQS200DK100 *BN/*SN	CYQS250DK140 *BN/*SN	CYQM100DK80 *BN/*SN	CYQM150DK80 *BN/*SN	CYQM200DK100 *BN/*SN	CYQM250DK140 *BN/*SN
Heating capacity	Speed 3	kW	9.0	11.6	16.2	9.2	11.0	13.4	19.9
Power input	Fan only	Nom. kW	0.35	0.46	0.58	0.37	0.56	0.75	0.94
	Heating	Nom. kW	0.35	0.46	0.58	0.37	0.56	0.75	0.94
Delta T	Speed 3	K	15			16	17	14	15
Casing	Colour		BN: RAL9010 / SN: RAL9006						
Dimensions	Unit	Height F/C/R	270/270/270						
		Width F/C/R	1,500/1,500/1,548	2,000/2,000/2,048	2,500/2,500/2,548	1,000/1,000/1,048	1,500/1,500/1,548	2,000/2,000/2,048	2,500/2,500/2,548
		Depth F/C/R	590/821/561						
Required ceiling void >		mm	420						
Door height	Max.	m	2.3 (1) / 2.15 (2) / 2.0 (3)	2.3 (1) / 2.15 (2) / 2.0 (3)	2.3 (1) / 2.15 (2) / 2.0 (3)	2.5 (1) / 2.4 (2) / 2.3 (3)	2.5 (1) / 2.4 (2) / 2.3 (3)	2.5 (1) / 2.4 (2) / 2.3 (3)	2.5 (1) / 2.4 (2) / 2.3 (3)
Door width	Max.	m	1.5	2.0	2.5	1.0	1.5	2.0	2.5
Weight	Unit	kg	66	83	107	57	73	94	108
Fan-Air flow rate	Heating	Speed 3	1,746	2,328	2,910	1,605	2,408	3,210	4,013
Sound pressure level	Heating	Speed 3	49	50	51	50	51	53	54
Refrigerant	Type / GWP		R-410A / 2,087.5						
Piping connections	Liquid/OD/Gas/OD	mm	9.52/16.0		9.52/19.0	9.52/16.0		9.52/19.0	
Required accessories (should be ordered separately)			Daikin wired remote control (BRC1E52A/B or BRC1D52)						
Power supply	Voltage	V	230						

			Large			
			CYQL100DK125 *BN/*SN	CYQL150DK200 *BN/*SN	CYQL200DK250 *BN/*SN	CYQL250DK250 *BN/*SN
Heating capacity	Speed 3	kW	15.6	23.3	29.4	31.1
Power input	Fan only	Nom. kW	0.75	1.13	1.50	1.88
	Heating	Nom. kW	0.75	1.13	1.50	1.88
Delta T	Speed 3	K	15			14
Casing	Colour		BN: RAL9010 / SN: RAL9006			
Dimensions	Unit	Height F/C/R	370/370/370			
		Width F/C/R	1,000/1,000/1,048	1,500/1,500/1,548	2,000/2,000/2,048	2,500/2,500/2,548
		Depth F/C/R	774/1,105/745			
Required ceiling void >		mm	520			
Door height	Max.	m	3.0 (1) / 2.75 (2) / 2.5 (3)	3.0 (1) / 2.75 (2) / 2.5 (3)	3.0 (1) / 2.75 (2) / 2.5 (3)	3.0 (1) / 2.75 (2) / 2.5 (3)
Door width	Max.	m	1.0	1.5	2.0	2.5
Weight	Unit	kg	76	100	126	157
Fan-Air flow rate	Heating	Speed 3	3,100	4,650	6,200	7,750
Sound pressure level	Heating	Speed 3	53	54	56	57
Refrigerant	Type / GWP		R-410A / 2,087.5			
Piping connections	Liquid/OD/Gas/OD	mm	9.52/16.0	9.52/19.0	9.52/22.0	
Required accessories (should be ordered separately)			Daikin wired remote control (BRC1E52A/B or BRC1D52)			
Power supply	Voltage	V	230			

(1) Favorable conditions: covered shopping mall or revolving door entrance (2) Normal conditions: little direct wind, no opposite open doors, building with ground floor only (3) Unfavorable conditions: location at a corner or square, multiple floors and/or open stairway



Ventilation

Heat Reclaim ventilation 115

Modulates the temperature and humidity of incoming fresh air

VAM-FC 116
VH - electrical heater 118

Air Handling unit applications 119

Fresh air solution for buildings with large ventilation requirements

ERQ 124
Overview & control possibilities 126





VAM - HEAT RECLAIM VENTILATION



DAIKIN AIR HANDLING UNIT AND ERQ/VRV HEAT PUMP

Outdoor units portfolio for connection to air handling units

System	Type	Product name	Condensing units		71	100	125	140	200	250
Air cooled	Heat pump	ERQ-AV1 ¹ Condensing Units	- High efficiency - High comfort levels - Easy design and installation - Maximize installation flexibility by offering 4 types of control systems			•	•	•		
		ERQ-AW1 ¹ Condensing Units					•		•	•

1) Only use the condensing units in combinations with an air handling unit.

Ventilation portfolio

Five components of indoor air quality

- › **Ventilation:** ensures the provision of fresh air
- › **Heat recovery:** recovers heat and moisture from the outgoing air to maximise comfort and efficiency
- › **Air processing:** heats or cools incoming fresh air maximising comfort and minimizing the load on the air conditioning installation
- › **Humidification:** optimises the balance between indoor and outdoor humidity
- › **Filtration:** removes dust, pollution and odours from the air

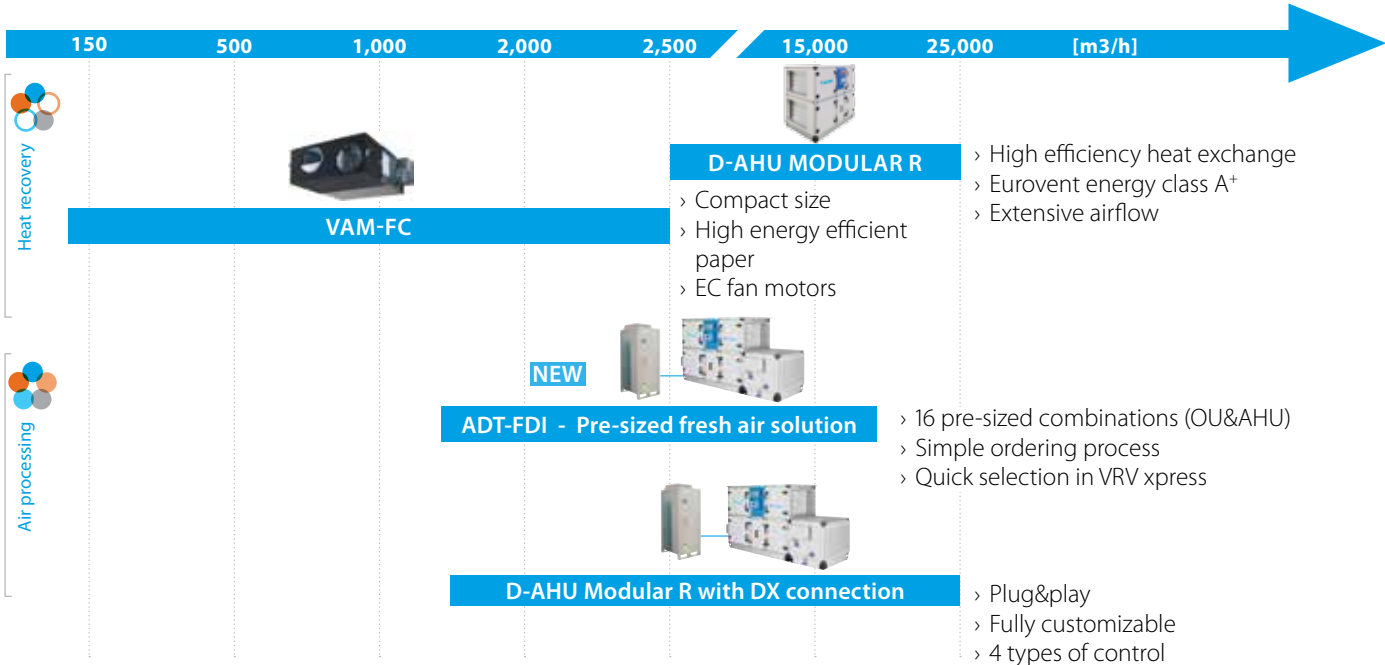
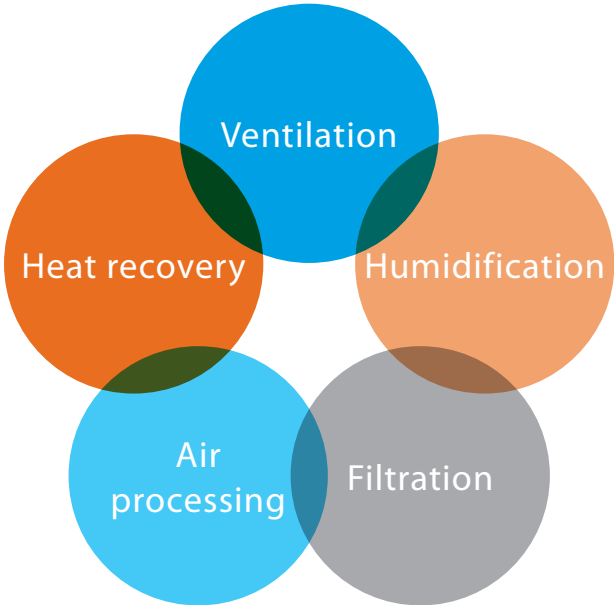

Heat reclaim ventilation

Ventilation with heat recovery as standard

- › Energy saving ventilation using indoor heating, cooling and moisture recovery
- › Ideal solution for shops, restaurants or offices requiring maximum floor space for furniture, decorations and fittings
- › Free cooling possible when outdoor temperature is below indoor temperature (eg. during nighttime)
- › Reduced energy consumption thanks to specially developed DC fan motor
- › Prevent energy losses from over-ventilation while improving indoor air quality with optional CO₂ sensor
- › Can be used as stand alone or integrated in the Sky Air or VRV system
- › Wide range of units: air flow rate from 150 up to 2,000 m³/h
- › Optional medium and fine dust filters M6, F7, F8 to meet customer request or legislation
- › Shorter installation time thanks to easy adjustment of nominal air flow rate, so less need for dampers compared with traditional installation.
- › Specially developed heat exchange element with High Efficiency Paper (HEP)

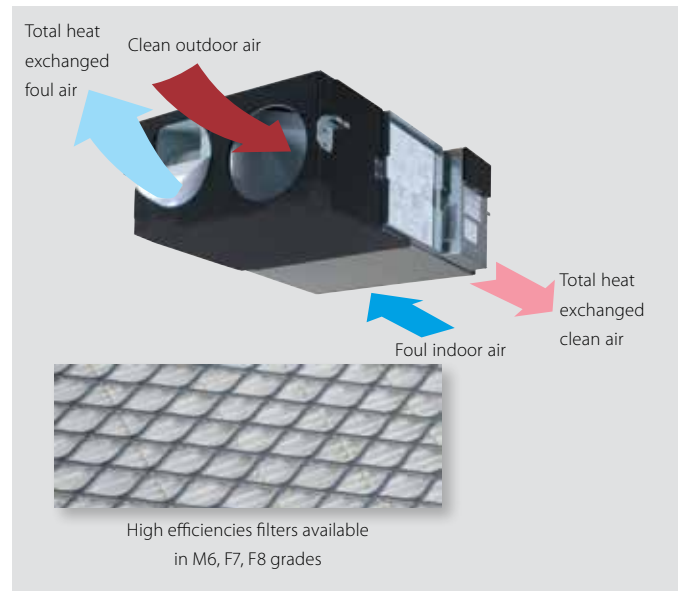

- › No drain piping needed
- › Can operate in over- and under pressure
- › Total solution for fresh air with Daikin supply of both VAM / VKM and electrical heaters

Prevent energy losses from over ventilation with CO₂ sensor

Enough fresh air is needed to create an enjoyable environment, but ventilating constantly is leading to energy waste. Therefore an optional CO₂ sensor can be installed which throttles or even switches off the ventilation system when there is enough fresh air in the room, thus saving energy.

Example of CO₂ sensor operation in a meeting room:

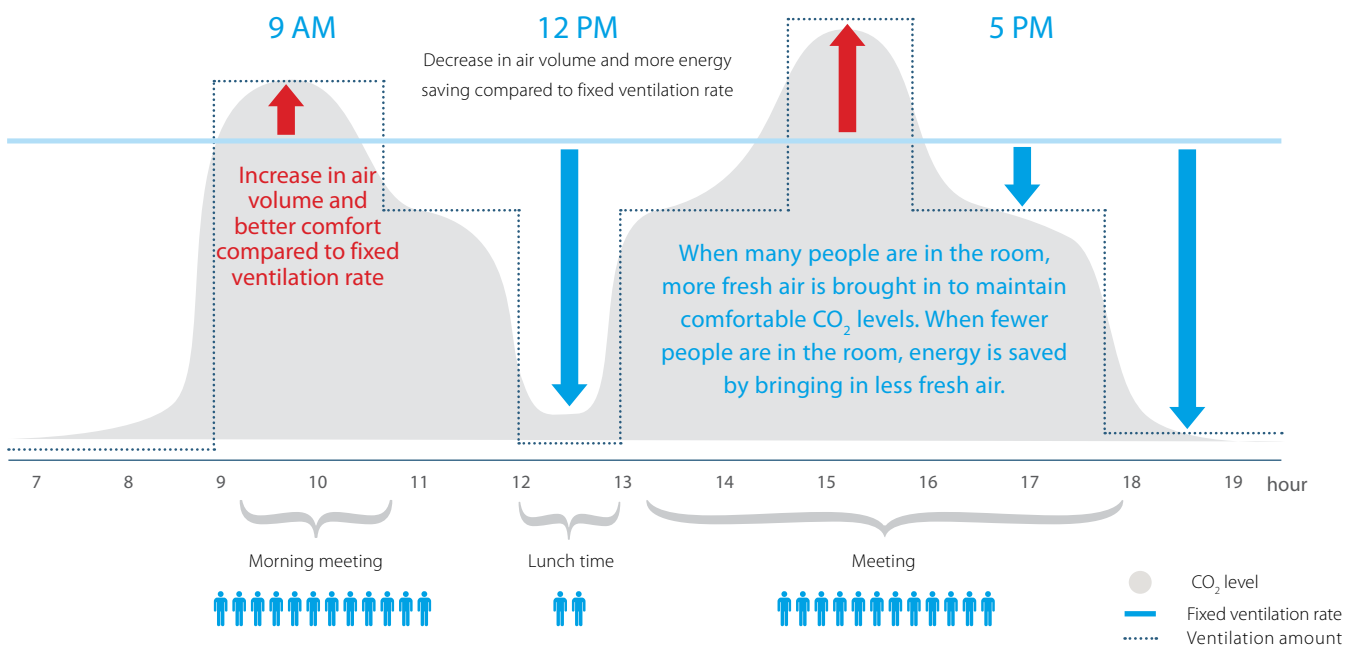

Using CO₂ sensors has the most energy-saving potential in buildings where occupancy fluctuates during a 24-hour period, is unpredictable and peaks at a high level. For example office buildings, government facilities, retail stores and shopping malls, movie theaters, auditoriums, schools, entertainment clubs and nightclubs. The ventilation unit's reaction to fluctuations in CO₂ can be easily adjusted through a field setting.

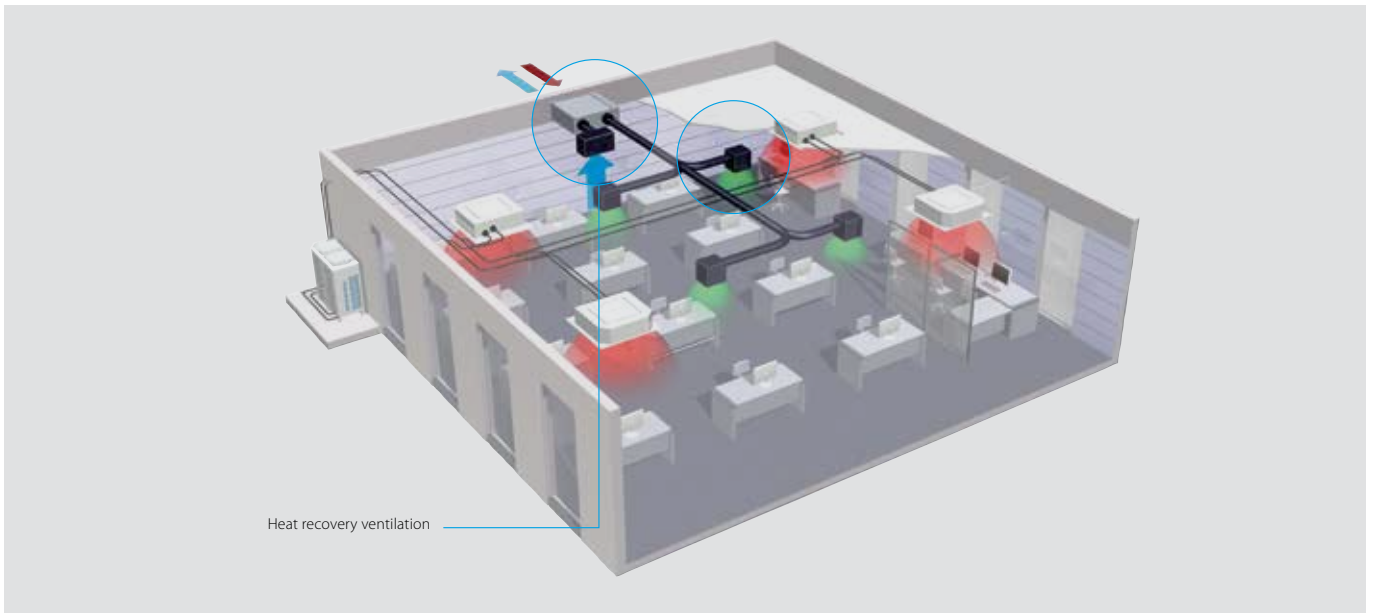

Heat recovery ventilation

High Efficiency Paper

Operation of the high efficiency paper.

Cross flow of air to exchange heat and moisture.

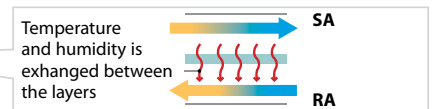
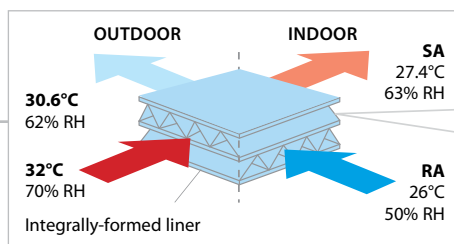

RH: Relative Humidity SA: Supply Air (to room) RA: Return Air (from room)

Ventilation			VAM	150FC	250FC	350FC	500FC	650FC	800FC	1000FC	1500FC	2000FC		
Power input - 50Hz	Heat exchange mode	Nom.	Ultra high/High/Low	kW										
	Bypass mode	Nom.	Ultra high/High/Low	kW										
Temperature exchange efficiency - 50Hz	Ultra high/High/Low		%			%								
	Enthalpy exchange efficiency - 50Hz	Cooling	Ultra high/High/Low	%										
Enthalpy exchange efficiency - 50Hz	Heating	Ultra high/High/Low	%											
	Heat exchange mode, bypass mode, fresh-up mode													
Air to air cross flow total heat (sensible + latent heat) exchange														
Specially processed non-flammable paper														
Dimensions	Unit	HeightxWidthxD	mm			mm			mm			mm		
Weight	Unit		kg			kg			kg			kg		
Casing	Material		Galvanised steel plate											
Fan-Air flow rate - 50Hz	Heat exchange mode	Ultra high/High/Low	m ³ /h			m ³ /h			m ³ /h			m ³ /h		
	Bypass mode	Ultra high/High/Low	m ³ /h			m ³ /h			m ³ /h			m ³ /h		
Fan-External static pressure - 50Hz	Ultra high/High/Low		Pa			Pa			Pa			Pa		
Air filter	Type		Multidirectional fibrous fleeces											
Sound pressure level - 50Hz	Heat exchange mode	Ultra high/High/Low	dBA			dBA			dBA			dBA		
	Bypass mode	Ultra high/High/Low	dBA			dBA			dBA			dBA		
Operation range	Min.		°CDB			°CDB			°CDB			°CDB		
	Max.		°CDB			°CDB			°CDB			°CDB		
	Relative humidity		%			%			%			%		
Connection duct diameter			mm			mm			mm			mm		
Power supply	Phase/Frequency/Voltage		Hz/V			Hz/V			Hz/V			Hz/V		
Current	Maximum fuse amps (MFA)		A			A			A			A		
Specific energy consumption (SEC)	Cold climate		kWh/(m ² ·a)			kWh/(m ² ·a)			kWh/(m ² ·a)			kWh/(m ² ·a)		
	Average climate		kWh/(m ² ·a)			kWh/(m ² ·a)			kWh/(m ² ·a)			kWh/(m ² ·a)		
	Warm climate		kWh/(m ² ·a)			kWh/(m ² ·a)			kWh/(m ² ·a)			kWh/(m ² ·a)		
SEC class			D / (6)			B / (6)								
Maximum flow rate at 100 Pa ESP	Flow rate		m ³ /h			m ³ /h			m ³ /h			m ³ /h		
	Electric power input		W			W			W			W		
Sound power level (Lwa)			dB			dB			dB			dB		
Annual electricity consumption			kWh/a			kWh/a			kWh/a			kWh/a		
Annual heating saved	Cold climate		kWh/a			kWh/a			kWh/a			kWh/a		
	Average climate		kWh/a			kWh/a			kWh/a			kWh/a		
	Warm climate		kWh/a			kWh/a			kWh/a			kWh/a		

(1) Measured on fan curve 15. Refer to fan curves. (2) Measured according to JIS B 8628 (3) Measured at reference flow rate according to EN13141-7 (4) Measured according to EN308 : 1997 (5) Clean the filter when the filter icon appears on the controller screen. Regular filter cleaning is important for delivered air quality and for the unit's energy efficiency. (6) In accordance with commission regulation (EU) No 1254/2014 | In accordance with commission regulation (EU) No 1253/2014 | At reference flow rate in accordance with commission regulation (EU) No 1254/2014

VH

- > Total solution for fresh air with Daikin supply of both VAM and electrical heaters
- > Increased comfort in low outdoor temperature thanks to the heated outdoor air
- > Integrated electrical heater concept (no additional accessories required)
- > Standard dual flow and temperature sensor
- > Flexible setting with adjustable setpoint
- > Increased safety with 2 cut-outs: manual & automatic
- > BMS integration thanks to:
 - Volt free relay for error indication
 - 0-10VDC input for setpoint control



ELECTRICAL HEATER FOR VAM	VH	(VH)
Supply voltage		220/250V ac 50/60 Hz. +/-10%
Output current (maximum)		19A at 40°C (ambient)
Temperature sensor		5k ohms at 25°C (table 502 1T)
Temperature control range		0 to 40°C / (0-10V 0-100%)
Control fuse		20 x 5mm 250mA
LED indicators		Power ON - Yellow Heater ON - Red (solid or flashing, indicating pulsed control) Airflow fault - Red
Mounting holes		98mm x 181mm centres 5 mm ø holes
Maximum ambient adjacent to terminal box		35°C (during operation)
Auto high temp. cutout		100°C Pre-set
Man. reset high temp. cutout		125°C Pre-set
Run relay		1A 120V AC or 1A 24V DC
BMS setpoint input		0-10VDC

		VH	1B	2B	3B	4B	4/AB	5B
Capacity	kW		1	1	1	1.5	2.5	2.5
Duct diameter	mm		100	150	200	250	250	300
Connectable VAM			VAM150FC -	VAM250FC VAM350FC	VAM500FC VAM650FC	VAM800FC VAM1000FC	VAM800FC VAM1000FC	VAM1500FC VAM2000FC

For the selection of the appropriate capacity, please refer to the VAM selection software.

Daikin air handling units solutions

You will find your match

Why choose Daikin air handling units with a DX connection?



Simplifying business

The unique total solution approach by Daikin helps businesses to propose better cross-pillar solutions, to increase their success ratio by providing unmatched product combinations to the end-user and to simplify the life of installers by supplying high-quality products coming from the same manufacturer. Contrary to other manufacturers, Daikin does not use OEM products in its AHU with DX offer. Many competitors are either offering OEM DX outdoor units or OEM AHU which create additional problems when warranties or faults arise.

Having a single interface for your business makes Daikin the right choice.

Supporting tools

Selecting an AHU in combination with a DX unit has never been this easy amongst manufacturers. The well known VRV xpress selection software has been modified to integrate pre-sized AHU combinations with DX outdoor units or just to select outdoor units connected to expansion valve kits.

If a more complex selection is required, then the new Astra web can be utilized to make unique tailor-made solutions for any project requirements.

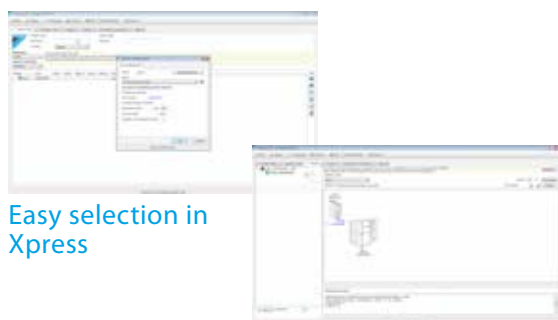

Easy selection in Xpress

One stop shop

Daikin is the only global manufacturer in the market **capable of offering a true plug & play solution** where Daikin AHUs manufactured by Daikin Applied Europe and certified by Eurovent, offer off-the-shelf compatibility with Daikin's unique VRV outdoor unit range for the best performance in the market. This unique integration of cross-pillar products under the same umbrella, gives the customer both peace-of-mind and added value when promoting a total solution approach.

Complete range of possibilities

Thanks to the **most complete offer in the market**, Daikin has the solution for all types of commercial applications requiring fresh air. Daikin provides ventilation solutions based on AHU from 2,500 m³/h up to 140,000 m³/h either with natural heat recovery or more advanced ventilation solutions where a VRV outdoor unit can be connected to the Daikin AHU for ultimate climate control. The harmonized control between the VRV outdoor unit and the AHU offer outstanding 24h/7 control of the system when connected to an iTM.

Advantages

- > Unique manufacturer offering a complete range
- > Plug&play solution
- > Direct iTM compatibility
- > VRV xpress supporting AHU business **NEW**
- > Pre-sized AHU+DX outdoor units for fresh air **NEW**

New pre-sized fresh air solution

Order AHU and outdoor in one step



Easy selection

- › 16 pre-selected combinations – to cover all fresh air needs in Europe
- › The right outdoor unit and the necessary connection kits to the coil of the AHU are factory mounted and configured.
- › Total solution – Daikin provides the complete solution

Fast quotation

- › Select as any other unit in Xpress selection software and show the solution in the report

Download Xpress now with the new pre-sized combination from my.daikin.eu

Easy ordering

- › AHU and outdoor unit are automatically selected in VRV xpress

Easy installation

- › Same pipe diameter from AHU to outdoor unit
- › Direct integration in **Intelligent Manager**

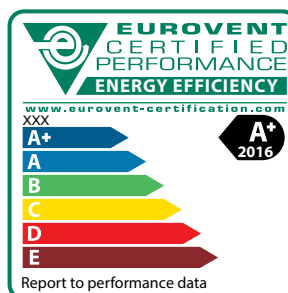

More details in the dedicated brochure

Pre-sized fresh air solution

High end ventilation with heat recovery

- › Pre-sized making selection, quotation, ordering easy
- › Connects directly to pre-selected Daikin DX outdoor units
- › IE premium efficiency motor
- › High efficiency heat wheel (heat recovery)
- › Compact design
- › Indoor air quality compliant with VDI hygiene guideline
- › Operating limits from -20°C up to +46 °C ambient temperature
- › Direct integration in intelligent Touch Manager for monitoring and control



			ADT03FDI-80	ADT03FDI-100	ADT03FDI-125	ADT04FDI-125	ADT04FDI-140	ADT04FDI-200	ADT05FDI-200	ADT05FDI-250	
Airflow	Nominal Air Flow valid for Cooling (1) and Heating(2)	m3/h	2,200	2,700	3,200	3,600	4,100	4,700	5,500	6,200	
Expansion valve kit	Type Number		EKEXV80	EKEXV100	EKEXV125	EKEXV125	EKEXV140	EKEXV200	EKEXV200	EKEXV250	
Control box	Type Number		EKEQFCBA 1								
Outdoor unit	Type Number		ERQ100AV1	ERQ125AV1	ERQ140AV1	ERQ200AW1	ERQ250AW1				
Energy Rating	Eurovent Energy Class ERP Compliance		A+	A	A+	A	A+	A	ErP 2018		
Heat Recovery Technology	Winter Nom.	%	Sorption Heat Wheel								
Heat Recovery Technology	Winter Nom.	%	81.5	79.2	76.9	81.1	79.6	77.8	79	77.4	
ESP	Nom.	Pa	200								
SFPv	Nom.	W/(m3/s)	1,388	1,508	1,660	1,402	1,512	1,637	1,456	1,575	
Supply Fan power input	Nom.	W	0.53	0.7	0.92	0.89	1.08	1.35	1.4	1.72	
Filter class	Supply Extract		F7+ F7 F7+ F7								
Dimensions	Unit	Height Width Depth	mm	1,540	1740				2,780		
Weight		Kg	549	659				840			
Total Power Input	Nom.	kW	1,55	2	2,3	2,25	2,63	3,15	3,25	3,86	
Power supply	Electrical voltage	V/ph/Hz	230V/1Ph/50Hz			400V/3Ph/50Hz					
Door opening (following supply air direction)	Right										
			ADT06FDI-250	ADT07FDI-250	ADT07FDI-140	ADT07FDI-200	ADT08FDI-200	ADT09FDI-200	ADT09FDI-250	ADT10FDI-250	
Airflow	Nominal Air Flow valid for Cooling (1) and Heating(2)	m3/h	6,900	7,400	8,000	8,700	10,000	11,500	13,200	14,900	
Expansion valve kit	Type Number		EKEXV250	EKEXV140	EKEXV200					EKEXV250	EKEXV250
Control box	Type Number		EKEQFCBA 1								
Outdoor unit	Type Number		ERQ250AW1	ERQ140AV1	ERQ200AW1	ERQ250AW1					
Energy Rating	Eurovent Energy Class ERP Compliance		A	A+	A	A	A+	A	A+	A+	
Heat Recovery Technology	Winter Nom.	%	Sorption Heat Wheel								
Heat Recovery Technology	Winter Nom.	%	77.9	80.2	79.3	78.1	78.4	79.7	77.9	80.2	
ESP	Nom.	Pa	200								
SFPv	Nom.	W/(m3/s)	1,580	1,438	1,491	1,581	1,429	1,438	1,569	1,397	
Supply Fan power input	Nom.	W	1.86	1.82	2.04	2.35	2.48	2.82	3.54	3.62	
Filter class	Supply Extract		F7+ F7 F7+ F7								
Dimensions	Unit	Height Width Depth	mm	1920	3,100	2,180	3,150	2,460	2,980	2,570	
Weight		Kg	1,400	1,600	1,940	1,489	1,594	2,300	1,973	1,973	
Total Power Input	Nom.	kW	887	1,063	1,489	5,08	5,37	6,06	7,44	7,6	
Power supply	Electrical voltage	V/ph/Hz	400V/3Ph/50Hz								
Door opening (following supply air direction)	Right										

(1) Cooling: indoor temp. 27°CDB, 19.0°CWB; outdoor temp. 35°CDB; equivalent piping length: 5m; level difference: 0m
 (2) Heating: indoor temp. 20°CDB; outdoor temp. -15°CDB; equivalent refrigerant piping: 5m; level difference: 0m

Why use ERQ condensing units for connection to air handling units?

High Efficiency

Daikin heat pumps are renowned for their high energy efficiency. Integrating the AHU with a heat recovery system is even more effective since an office system can frequently be in cooling mode while the outdoor air is too cold to be brought

inside in an unconditioned state. In this case heat from the offices is merely transferred to heat up the cold incoming fresh air.

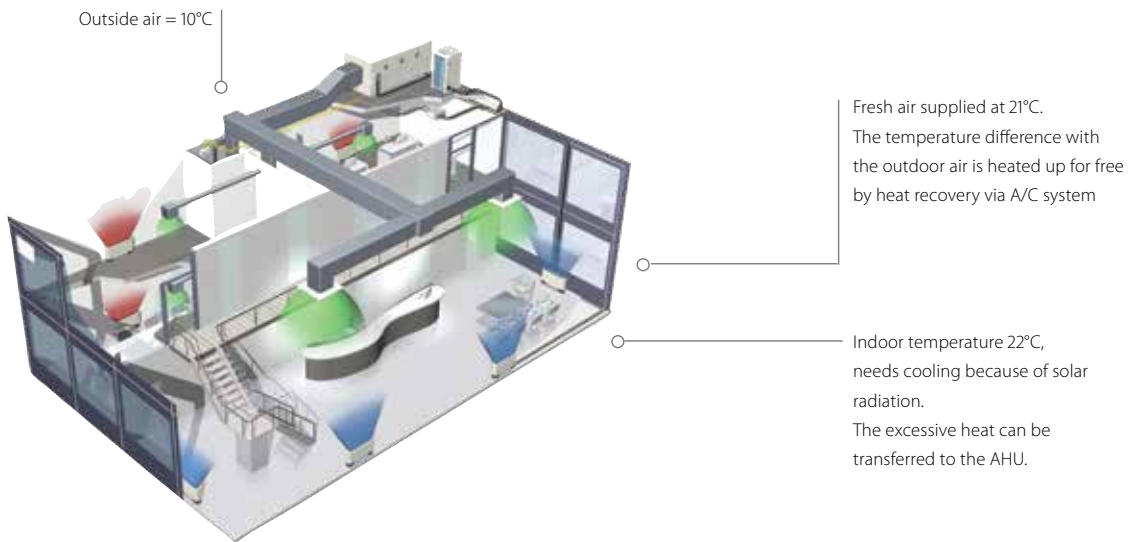

Fast response to changing loads resulting in high comfort levels

Daikin ERQ units respond rapidly to fluctuations in supply air temperature, resulting in a steady indoor temperature and resultant high comfort levels for the end user. The ultimate is the VRV range which improves comfort even more by offering continuous heating, also during defrost.

Easy Design and Installation

The system is easy to design and install since no additional water systems such as boilers, tanks and gas connections etc. are required. This also reduces both the total system investment and running cost.

Daikin Fresh air package

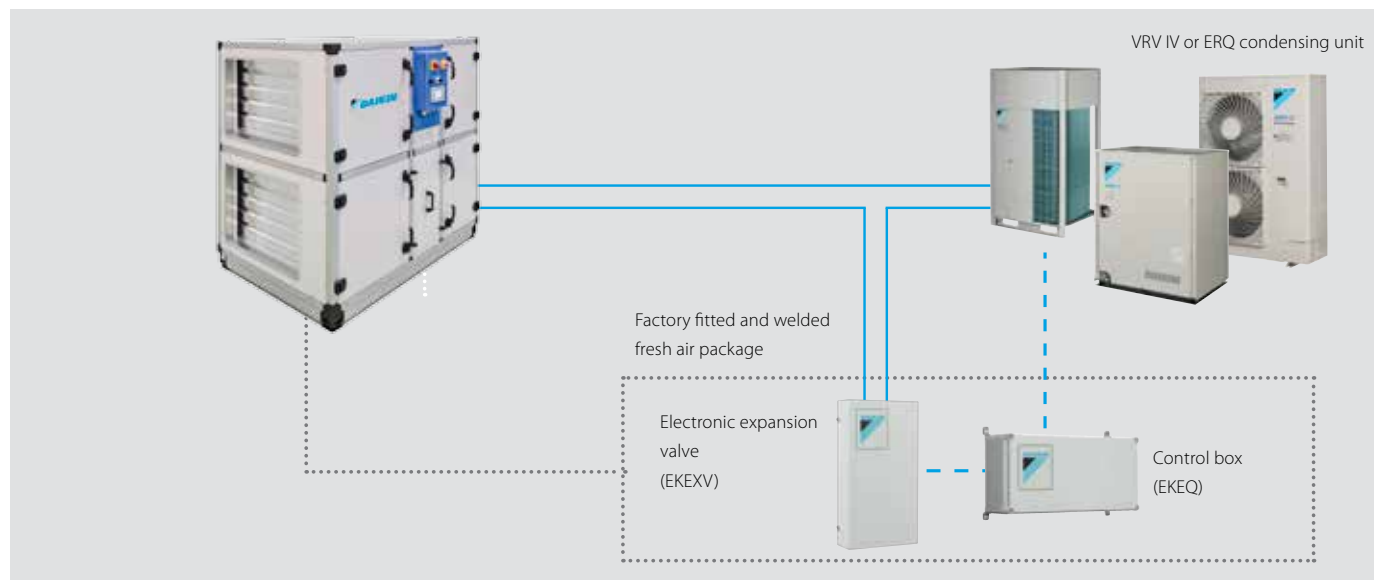

In order to maximise installation flexibility, 4 types of control systems are offered

W control: Off the shelf control of air temperature (supply air temperature, return air temperature, room temperature) via any DDC controller, easy to setup

X control: Precise control of air temperature (supply air temperature, return air temperature, room temperature) requiring a preprogrammed DDC controller (for special applications)

Z control: Control of air temperature (return air temperature, room temperature) via Daikin control (no DDC controller needed)

Y control: Control of refrigerant (T_e/T_c) temperature via Daikin control (no DDC controller needed)

1. W control ($T_s/T_r/T_{ROOM}$ control):

Air temperature control via DDC controller

Room temperature is controlled as a function of the air handling unit return air or supply air (customer selection). The DDC controller is translating the temperature difference between set point and return air temperature (or supply air temperature or room temperature) into a proportional 0-10V signal which is transferred to the Daikin control box (EKEQFCBA). This voltage modulates the capacity requirements of the outdoor unit.

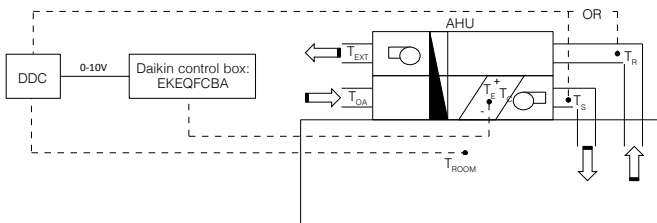

2. X control ($T_s/T_r/T_{ROOM}$ control):

Precise air temperature control via DDC controller

Room temperature is controlled as a function of the air handling unit return air or supply air (customer selection). The DDC controller is translating the temperature difference between set point and return air temperature (or supply air temperature or room temperature) into a reference voltage (0-10V) which is transferred to the Daikin control box (EKEQFCBA). This reference voltage will be used as the main input value for the compressor frequency control.

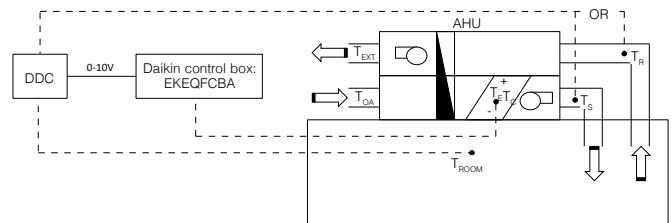

3. Y control (T_e/T_c control):

By fixed evaporating /condensing temperature

A fixed target evaporating or condensing temperature can be set by the customer. In this case, room temperature is only indirectly controlled. A Daikin wired remote control (BRC1D52 or BRC1E53A/B/C - optional) have to be connected for initial set-up but not required for operation.

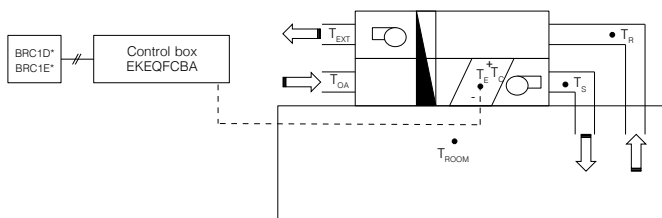

4. Z control (T_r/T_{ROOM} control):

Control your AHU just like a VRV indoor unit with 100% fresh air

Allows the possibility to control the AHU just like a VRV indoor unit. Meaning temperature control will be focused on return air temperature from the room into the AHU. Requires BRC1D52 or BRC1E53A/B/C for operation. This the only control that allows the combination of other indoor units to the AHU at the same time.

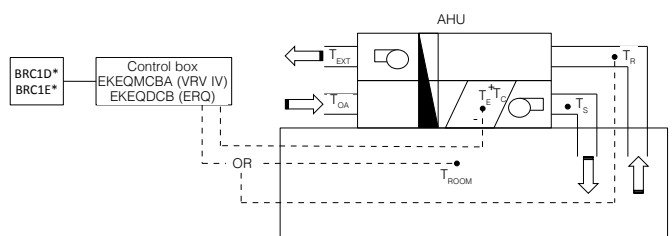

T_s = Supply air temperature T_r = Return air temperature T_{OA} = Outdoor air temperature T_{ROOM} = Room air temperature
 T_{EXT} = Extraction air temperature T_e = Evaporating temperature T_c = Condensing temperature

	Option kit	Features
Possibility W	EKEQFCBA	Off-the-shelf DDC controller that requires no pre-configuration
Possibility X		Pre-configured DDC controller required
Possibility Y		Using fixed evaporating temperature, no set point can be set using remote control
Possibility Z	EKEQDCB EKFQMCBA*	Using Daikin infrared remote control BRC1D52 or BRC1E52A/B Temperature control using return air temperature or room temperature (via remote sensor)

* EKEQMCB (for 'multi' application)

ERQ - for smaller capacities (from 100 to 250 class)

A basic fresh air solution for pair application

- › Inverter controlled units
- › Heat pump
- › R-410A
- › Wide range of expansion valve kits available
- › Perfect for the Daikin Modular air handling unit

The "Daikin Fresh Air Package" provides a complete Plug & Play Solution including AHU, ERQ or VRV Condensing Unit and all unit control (EKEQ, EKEX, DDC controller) factory mounted and configured. The easiest solution with only one point of contact.



ERQ-AW1

Ventilation				ERQ	100AV1	125AV1	140AV1
Capacity range				HP	4	5	6
Cooling capacity Nom.				kW	11.2	14.0	15.5
Heating capacity Nom.				kW	12.5	16.0	18.0
Power input	Cooling	Nom.	kW	2.81	3.51	4.53	
	Heating	Nom.	kW	2.74	3.86	4.57	
EER					3.99		3.42
COP					4.56	4.15	3.94
Dimensions	Unit	mm		1,345x900x320			
Weight				Unit	kg		
Fan-Air flow rate	Cooling	Nom.	m ³ /min	120			
	Heating	Nom.	m ³ /min	102	106	105	
Sound power level	Cooling	Nom.	dB(A)	66	67	69	
Sound pressure level	Cooling	Nom.	dB(A)	50	51	53	
	Heating	Nom.	dB(A)	52	53	55	
Operation range	Cooling	Min./Max.	°CDB	-5/46			
	Heating	Min./Max.	°CWB	-20/15.5			
	On coil temperature	Heating Min.	°CDB	10			
		Cooling Max.	°CDB	35			
Refrigerant	Type / GWP			R-410A / 2.087,5			
	Charge			kg/ TCO ₂ Eq			
Piping connections	Liquid	OD	mm	9.52			
	Gas	OD	mm	15.9		19.1	
	Drain	OD	mm	26x3			
Power supply	Phase/Frequency/Voltage			Hz/V			
Current	Maximum fuse amps (MFA)			A			
				32.0			

Ventilation				ERQ	125AW1	200AW1	250AW1
Capacity range				HP	5	8	10
Cooling capacity Nom.				kW	14.0	22.4	28.0
Heating capacity Nom.				kW	16.0	25.0	31.5
Power input	Cooling	Nom.	kW	3.52	5.22	7.42	
	Heating	Nom.	kW	4.00	5.56	7.70	
EER					3.98	4.29	3.77
COP					4.00	4.50	4.09
Dimensions	Unit	mm		1,680x635x765	1,680x930x765		
Weight				Unit	kg		
Fan-Air flow rate	Cooling	Nom.	m ³ /min	159	187	240	
	Heating	Nom.	m ³ /min	95	171	185	
Sound power level	Nom.	dB(A)		95	171	185	
Sound pressure level	Nom.	dB(A)		72	78	58	
Operation range	Cooling	Min./Max.	°CDB	54			
	Heating	Min./Max.	°CWB	57			
	On coil temperature	Heating Min.	°CDB	-20/15			
		Cooling Max.	°CDB	10			
Refrigerant	Type / GWP			R-410A / 2.087,5			
	Charge			kg/ TCO ₂ Eq			
Piping connections	Liquid	OD	mm	6.2/12.9	7.7/16.1	8.4/17.5	
	Gas	OD	mm	15.9	19.1	22.2	
Power supply	Phase/Frequency/Voltage			Hz/V			
Current	Maximum fuse amps (MFA)			A			
				16	3N~/50/400	25	

Integration of ERQ in third party air handling units

a wide range of expansion valve kits and control boxes

Combination table

		Control box			Expansion valve kit										Mixed connection with VRV indoor units	
		EKEQDCB	EKEQFCBA	EKEQMCBA	EKE XV50	EKE XV63	EKE XV80	EKE XV100	EKE XV125	EKE XV140	EKE XV200	EKE XV250	EKE XV400	EKE XV500		
		Z control	W,X,Y control	Z control	-	-	-	-	-	-	-	-	-	-	-	-
1-phase	ERQ100	P	P	-	-	P	P	P	P	-	-	-	-	-	-	-
	ERQ125	P	P	-	-	P	P	P	P	P	-	-	-	-	-	-
	ERQ140	P	P	-	-	-	P	P	P	P	-	-	-	-	-	-
3-phase	ERQ125	P	P	-	-	P	P	P	P	P	-	-	-	-	-	-
	ERQ200	P	P	-	-	-	-	P	P	P	P	P	-	-	-	-
	ERQ250	P	P	-	-	-	-	-	P	P	P	P	-	-	-	-
VRV III		-	-	n1	n1	n1	n1	n1	n1	n1	n1	n1	n1	n1	n1	Mandatory
VRV IV H/P / VRV IV W-series VRV IV S-series		-	P (1 -> 3)	n2	n2	n2	n2	n2	n2	n2	n2	n2	n2	n2	n2	Possible (not mandatory)
VRV IV H/R VRV IV i-series		-	-	n1	n1	n1	n1	n1	n1	n1	n1	n1	n1	n1	n1	Mandatory

- P (pair application): combination depends on the capacity of the air handling unit
- n1 (multi application) - Combination of AHUs and VRV DX indoors (mandatory). To determine the exact quantity please refer to the engineering data book.
- n2 (multi application) - Combination of AHUs and VRV DX indoors (not mandatory). To determine the exact quantity please refer to the engineering data book.
- Control box EKEQFA can be connected to some types of VRV IV outdoor units (with a maximum of 3 boxes per unit). Do not combine EKEQFA control boxes with VRV DX indoor units, RA indoor units or hydroboxes

Capacity table

Cooling

EKE XV Class	Allowed heat exchanger capacity (kW)		
	Minimum	Standard	Maximum
50	5.0	5.6	6.2
63	6.3	7.1	7.8
80	7.9	9.0	9.9
100	10.0	11.2	12.3
125	12.4	14.0	15.4
140	15.5	16.0	17.6
200	17.7	22.4	24.6
250	24.7	28.0	30.8
400	35.4	45.0	49.5
500	49.6	56.0	61.6

Saturated evaporating temperature: 6°C, SH: 5K
Air temperature: 27°C DB / 19°C WB

Heating

EKE XV Class	Allowed heat exchanger capacity (kW)		
	Minimum	Standard	Maximum
50	5.6	6.3	7.0
63	7.1	8.0	8.8
80	8.9	10.0	11.1
100	11.2	12.5	13.8
125	13.9	16.0	17.3
140	17.4	18.0	19.8
200	19.9	25.0	27.7
250	27.8	31.5	34.7
400	39.8	50.0	55.0
500	55.1	63.0	69.3

Saturated condensing temperature: 46°C, SC: 3K
Air temperature: 20°C DB

EKE XV - Expansion valve kit for air handling applications

Ventilation		EKE XV	50	63	80	100	125	140	200	250	400	500
Dimensions	Unit	mm	401x215x78									
Weight	Unit	kg	2.9									
Sound pressure level	Nom.	dB(A)	45									
Operation range	On coil temperature	Heating Min. °CDB	10 (1)									
		Cooling Max. °CDB	35 (2)									
Refrigerant	Type / GWP		R-410A / 2.087,5									
Piping connections	Liquid OD	mm	6.35				9.52				12.7	15.9

(1) The temperature of the air entering the coil in heating mode can be reduced to -5°CDB. Contact your local dealer for more information. (2) 45% Relative humidity.

EKEQ - Control box for air handling applications

Ventilation		EKEQ	FCBA	DCB	MCBA
Application			See note	Pair	Multi
Outdoor unit			ERQ / VRV	ERQ	VRV
Dimensions	Unit	mm	132x400x200		
Weight	Unit	kg	3.9	3.6	
Power supply	Phase/Frequency/Voltage	Hz/V	1~/50/230		

The combination of EKEQFCBA and ERQ is in pair application. The EKEQFCBA can be connected to some type of VRV IV outdoor units with a maximum of 3 control boxes. The combination with DX indoor units, hydroboxes, RA outdoor units, ... is not allowed. Refer to the combination table drawing of the outdoor unit for details.

Market leading controls

- ✓ Intuitive & user-friendly interface
- ✓ Cross pillar integration
- ✓ Cloud control
- ✓ Smart energy management
- ✓ Integration of Daikin and third party products



Online Controller

- › Simple control from your smartphone
- › Control your device at anytime from anywhere
- › For single shop control
- › 3rd party products and services integration via IFTTT
- › IFTTT is a solution that connects compatible 3rd party products and services (smart meters, lights, thermostats, ...), so they work best for you.

›
→ [more information on page 132](#)



DCC601A51

Advanced centralised controller with Cloud connection

- › Simply control your entire building centrally
- › Total solution concept (integration of Split, Sky Air, VRV, ventilation, air curtains and hot water)
- › Stylish optional screen fits any interior
- › Cloud connection offers additional services such as online control, energy monitoring, comparison of energy consumption of multiple sites
- › Connect up to 32 indoor units

→ [more information on page „Advanced centralised controller with Cloud connection“ on page 140](#)



Control Systems

Control Systems 128

Requirements tables per application	128	
Online controller	130	NEW
Individual control systems	132	NEW
Wired / infrared remote controls	136	
Centralised control systems	138	
Centralised remote control / Unified ON/OFF control / Schedule timer	138	
Adapter DTA113B51	139	
intelligent Controller	139	
Advanced centralised controller with Cloud connection	140	
Mini building management system	142	
intelligent Manager	142	
Standard protocol interfaces	146	
Modbus interface	146	
RTD-20 Retail Economiser	146	
DIII-net Modbus interface	150	
KNX Interface	151	
Wireless room temperature sensor	152	
Wired room temperature sensor	152	
Other integration devices	153	

Options & Accessories 154

Find out more about our control systems online:
www.daikineurope.com/commercial/needs/controls

Requirement tables per application

Daikin offers various control solution adapted to the requirements of even the most demanding commercial application.

- › Basic control solutions for those customers with few requirements and limited budget
- › Integrating control solutions for those customers that would like to integrate Daikin units into their existing BMS system
- › Advanced control solutions for those customers that expect Daikin to deliver a mini BMS solution, including advance energy management

Shop

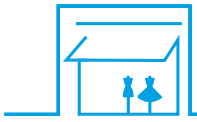

	Unit control		Integrating control			Advanced control	
	BRC1H51 BRC1E53A/B/C	RTD-20	RTD-Net	KLIC-DI	EKMBDXA	DCC601A51	DCM601A51
	1 remote controller for 1 indoor unit (group)	1 gateway for 1 indoor unit (group)	1 gateway for 1 indoor unit (group)	1 gateway for 1 indoor unit	1 gateway for max. 64 indoor unit(s) (groups) & 10 outdoors	1 unit for 32 indoor unit(s)	1 iTM for 64 indoor unit(s) (groups) (1)
Automatic control of A/C	●	●	●	●	●	●	●
Limited control possibilities for shop staff	●	●	●	●	●	●	●
Create zones within the shop		●				●	●
Interlock with eg. Alarm, PIR sensor		●				●	●
Integrate Daikin units into existing BMS via Modbus			●		●		
Integrate Daikin units into existing BMS via KNX				●			
Integrate Daikin units into existing BMS via HTTP						●	
Monitor energy consumption						● (2)	●
Advanced energy management						● (2)	●
Allows free cooling						●	●
Integrate Daikin products cross pillars into Daikin BMS							●
Integrate third party products into Daikin BMS						●	●
Online control						● (2)	●
Manage multiple sites						● (2)	

(1) : 7 iTM plus adapters (DCM601A52) can be added to have 512 indoor groups and 80 outdoor (systems) (2) Via cloud control

Hotel



	Unit control	Integrating control		Advanced control	
	BRC1H51 BRC2/3E52C	RTD-Net	KLIC-DI	DCS601C51	DCM601A51
	1 remote controller for 1 indoor unit (group)	1 gateway for 1 indoor unit (group)	1 gateway for 1 indoor unit	1 iTC for 64 indoor unit(s) (groups)	1 iTM for 64 indoor unit(s) (groups) (1)
Hotel guest can control & monitor basic functionalities from his room	●	●	●	●	●
Limited control possibilities for hotel guests	●	●	●	●	●
Interlock with window contact	● (2)				●
Interlock with key-card	● (2)				●
Integrate Daikin units into existing BMS via Modbus		●			
Integrate Daikin units into existing BMS via KNX			●		
Integrate Daikin units into existing BMS via HTTP				●	
Monitor energy consumption					●
Advanced energy management					●
Integrate Daikin products cross pillars into Daikin BMS					●
Integrate third party products into Daikin BMS					●
Online control					●

(1) : 7 iTM plus adapters (DCM601A52) can be added to have 512 indoor groups and 80 outdoor (systems) (2) Via BRP7A51 adapter

Office



	Unit control	Integrating control			Advanced control		
	BRC1H51 BRC1E53A/B/C	EKMBDXA	DMS504B51	DMS502A51 / DAM412B51	DCS302C51 / DST301B51	DCS601C51	DCM601A51
	1 remote controller for 1 indoor unit (group)	1 gateway for max. 64 indoor unit(s) (groups) & 10 outdoors	1 gateway for 64 indoor unit(s) (groups)	1 gateway for 128 indoor unit(s) (groups), 20 outdoors (2)	1 R/C for max. 64 groups, 128 indoor units, 10 outdoors	1 iTC for 64 indoor unit(s) (groups)	1 iTM for 64 indoor unit(s) (groups) (1)
Automatic control of A/C	●	●	●	●	● (3)	●	●
Centralised control for management		●	●	●	●	●	●
Local control for office workers	●	●	●	●	●	●	●
Limited control possibilities for office workers	●					●	●
Integrate Daikin units into existing BMS via Modbus		●					
Integrate Daikin units into existing BMS via HTTP						●	
Integrate Daikin units into existing BMS via LonTalk			●				
Integrate Daikin units into existing BMS via BACnet				●			
Energy consumption read out	●						
Monitor energy consumption							●
Advanced energy management							●
Integrate Daikin products cross pillars into Daikin BMS							●
Integrate third party products into Daikin BMS							●
Online control							●

(1) : 7 iTM plus adapters (DCM601A52) can be added to have 512 indoor groups and 80 outdoor (systems)
 (2) : extension needed to go to 256 indoor unit(s) (groups), 40 outdoors
 (3) : ON/OFF only

Infrastructure cooling



	Unit	Integrating	Advanced
	BRC1H51 BRC1E53A/B/C	RTD-10	DCM601A51
	1 remote controller for 1 indoor unit (group) (2)	1 gateway for 1 indoor unit (group) Up to 8 gateways can be linked together	1 iTM for 64 indoor unit(s) (groups) (1)
Automatic control of A/C	●	●	●
Back-up operation	●	●	●
Duty rotation	●	●	●
Limited control possibilities in the infrastructure cooling room	●	●	●
If room temperature above max., then show alarm & start standby unit.	●	●	●
If an error occurs, an alarm will be shown.	●	●	●

(1) : 7 iTM plus adapters (DCM601A52) can be added to have 512 indoor groups and 80 outdoor (systems) (2) Infrastructure cooling functions only compatible with indoor units connected to Seasonal Smart outdoor units.

Online controller

BRP069A41/42/43/45/61/62 /81

Always in control, no matter where you are



The Daikin Online Controller application can control and monitor the status of your heating system or up to 50 split air conditioning units and allows you to:

Monitor:

- › The status of your air conditioner or heating system
- › Consult **energy consumption graphs**

Control:

- › The **operation mode**, set temperature, fan speed and powerful mode, air direction and filtering (streamer) function
- › Remotely control your system and domestic hot water
- › **Zone control:** control **multiple** units at once (Split and Daikin Altherma integrated bi-zone only)

Schedule:

- › Schedule the set temperature and operation mode with up to **6 actions per day for 7 days**
- › Enable **holiday mode**
- › View in an intuitive mode
- › 3rd party products & services integration via IFTTT
- › Demand control/power power limitation (Split only)

App with intuitive lay-out

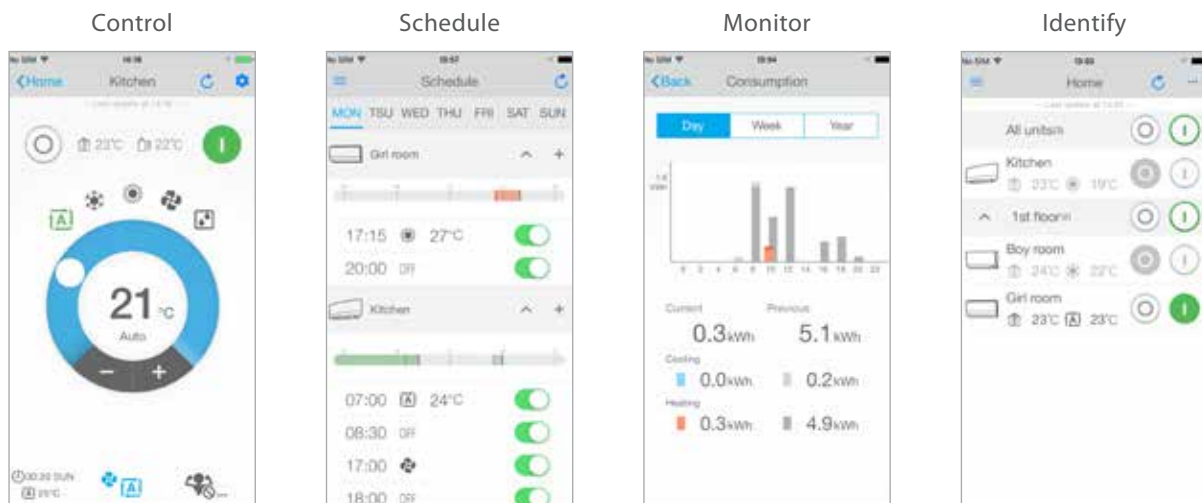

Control operation mode, temperature, air purification, fan speed & direction

Schedule the set temperature, operation mode and fan speed

Monitor your energy consumption, set holiday schedule

Identify the rooms in your house

Connectable units

BRP069A41
 › FTXG-LW/S
 › FTXJ-MW/S *

BRP069A42
 › FTXZ-N
 › FTXS35-42-50K
 › FTXS60-71G
 › FTX50-60-71GV
 › FTXLS-K3
 › FVXG-K
 › FVXS-F
 › FLXS-B(9)
 › ATXS35-50K

BRP069A43
 › CTXS15-35K
 › FTXS20-25K
 › FTX20-25-35J3
 › FTXL-JV
 › ATXS20-25K
 › ATX-J3
 › ATXL-JV

BRP069A45
 › FTX20-25-35KV
 › FTX50-60KV
 › ATX-KV
 › C/FTXM-M
 › FTXP-KV
 › ATXM-M
 › ATXP-KV

BRP069A61/62
Daikin Altherma ground source heat pump
 › EGSQH-A9W
Daikin Altherma hybrid heat pump
 › EHYHBH(X)-AV3(2)
Daikin Altherma low temperature split
 › EHBH(X)-CB
 › EHVH(X)-CB
Daikin Altherma low temperature monobloc
 › EBLQ-CV3
 › EDLQ-CV3

BRP069A81
Ceiling mounted
 › FCAHG-G
 › FCAG-A
 › FFA-A
Concealed ceiling
 › FDXM-F3
 › FBA-A
 › FDA-A
 › ADEQ-C
Wall mounted
 › FAA-A
Ceiling suspended
 › FHA-A
 › FUA-A
Floor standing
 › FVA-A
 › FNA-A

* controller included with the unit



IFTTT: make your work flow

IFTTT is a solution that connects compatible 3rd party products and services (smart meters, lights, thermostats, ...), so they work best for you.

Within IFTTT, 2 operation set-ups can be made:

- › DO: it simply executes an action (e.g.: on/off)
- › IFTTT stands for If This Then That and allows you to automate actions (Then That) depending on certain triggers (If This)

Example

IF you exit an area, **THEN** turn off the heating.
 The trigger is location, which is determined by your smartphone. If you leave an area, such as your house for example, your heating will turn off automatically.

IF there is an error signal on the unit, **THEN** a text message is sent (to the installer/user/...)

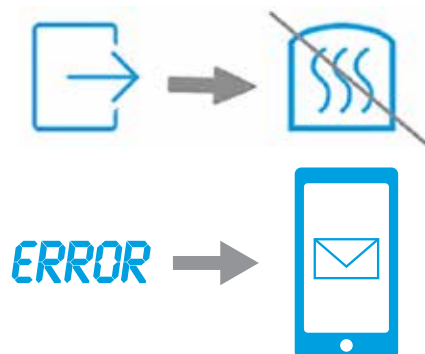

Wired remote controller with premium design

BRC1H51 W/S/B

User-friendly wired remote controller with premium design



Glossy white
BRC1H51W

Experience a new way of air conditioning control & commissioning



Silver metallic
BRC1H51S



Black matte
BRC1H51B

A complete redesigned controller focussed to enhanced user experience

- Sleek and elegant design
- Intuitive touch button control
- User-friendly symbol driven interface
- 3 colors to match any interior design
- Compact, flat back for easy wall installation

Advanced settings can be easily done via your smartphone



- BLE (Bluetooth Low Energy) communication
- Intuitive setting of schedules and advanced functions for end users / property managers
- Easy commissioning for installers
- Time saving copy possibility of settings between different controllers (e.g. in hotel applications)

Schedule

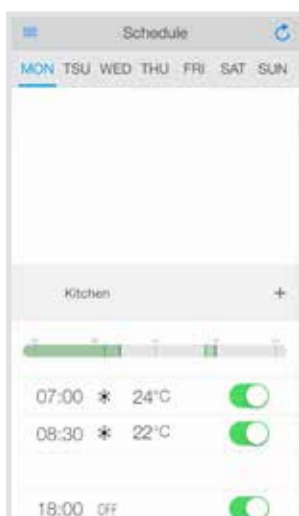

Advanced user settings



Installer settings

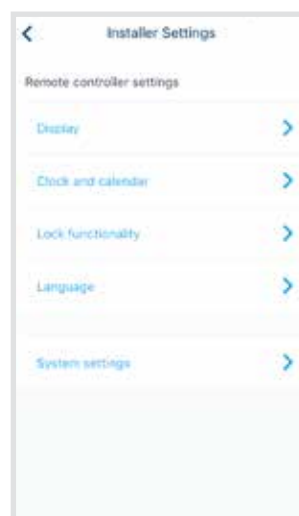

Field settings



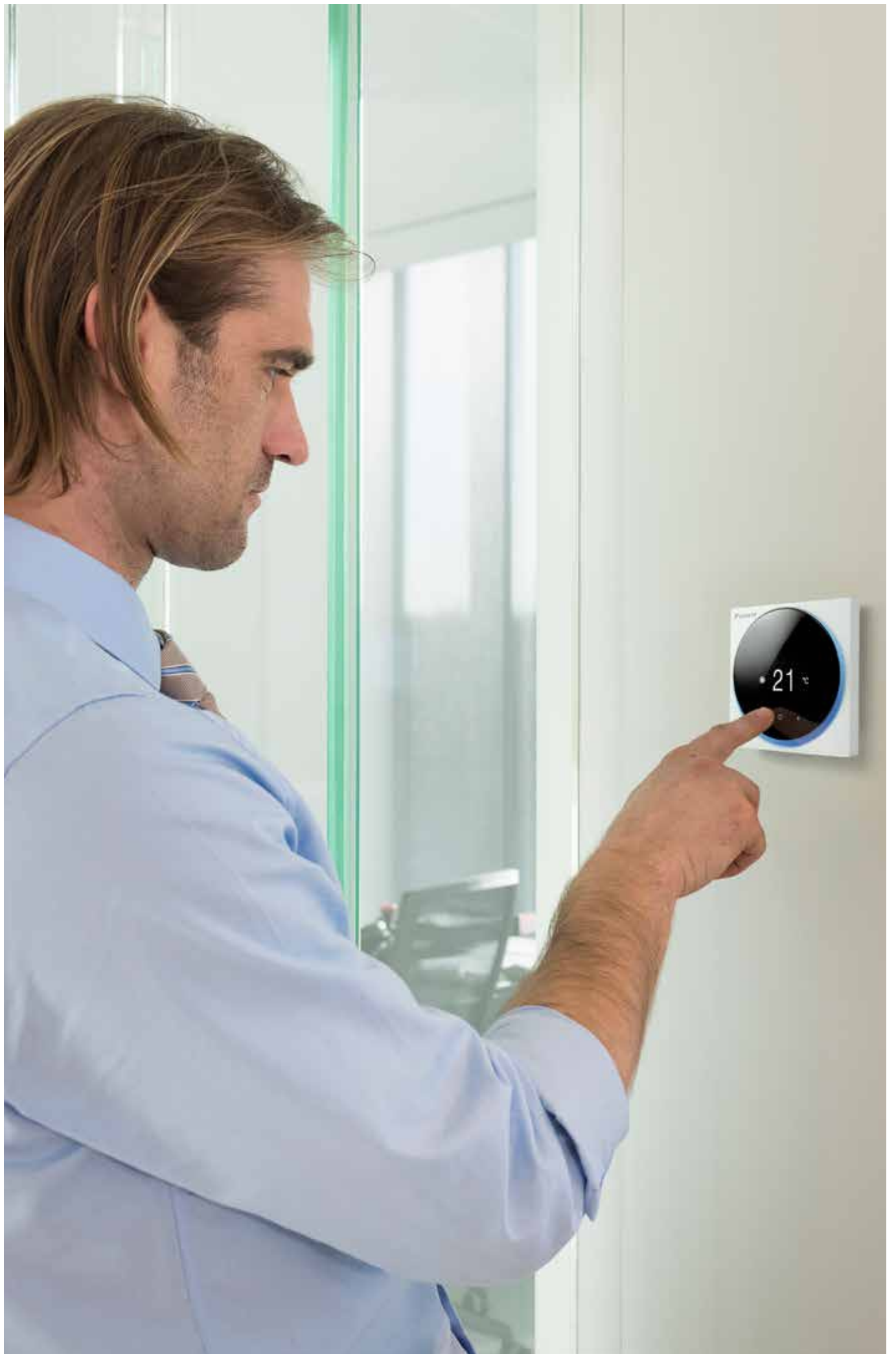

BRC1H51W / BRC1H51S / BRC1H51K

Premium touch button remote control for Sky Air and VRV



BRC1H51W



BRC1H51S



BRC1H51K

A series of energy saving functions that can be individually selected

- › Demand control: decreases the power consumption to 70 or 40 % when other large appliances need to be switched on (1)
- › Temperature range limit
- › Setback function
- › Presence & floor sensor connection (available on round flow and fully flat cassette)
- › kWh indication (2)
- › Set temperature auto reset
- › Off timer

Temperature range limit avoids excessive heating or cooling

Save energy by constraining the lower temperature limit in cooling and upper temperature limit in heating mode.

note : Also available in auto cooling/heating change over mode.

kWh indication keeps track of your consumption (2)

The kWh indication shows an indicative electricity consumption of the last day/month/year.

Other functions

- › Up to 3 independent schedules can be set, so the user can easily change the schedule himself throughout the year (e.g. Summer, winter, mid-season)
- › Possibility to individually restrict menu functions
Easy to use: all main functions directly accessible
- › Choice of display between symbol or text
- › Easy setup: clear graphical user interface for advanced menu settings
- › Remote control save mode : screen turns off when no person is changing mode or adjusting settings
- › Selection of quiet mode function for the outdoor unit (1)
- › Real time clock with auto update to daylight saving time
- › Built-in backup power: when a power failure occurs all settings remain stored up to 48 hours



Cost-effective solution for infrastructure cooling applications

- › Only in combination with RZAG* / RZQG*
- › Duty rotation

After a certain period of time, the operating unit will go into standby and the standby unit will take over, increasing lifetime of the system
Rotation interval can be set from 6h, 12h, 24h, 72h, 96h, weekly

- › Back-up operation: if one unit fails, the other unit will automatically start

(1) Only available on RZAG*, RZASG*, RZQG*, RZQSG*

(2) For Sky Air FBA, FCAG and FCAHG pair combinations only

Hotel application functions

- › Energy saving thanks key card, window contact integration and set point limitation (BRP7A51)
- › Flexible setback function ensures room temperature remains within comfortable limits to ensure guest comfort

Key card and window contact integration

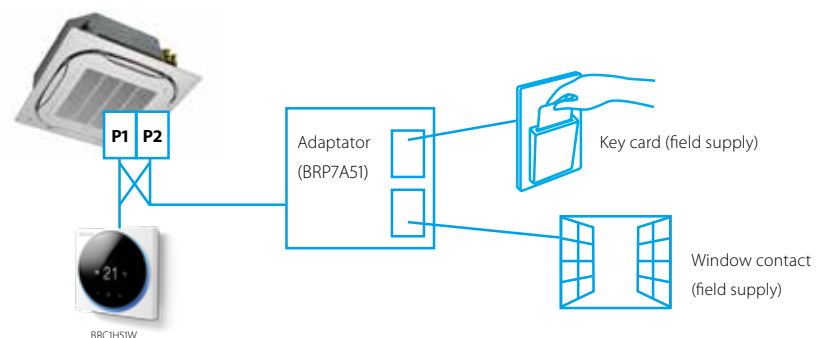

Advanced settings/read out can be easily done via your smartphone

BRC1E53A/B/C

User friendly remote control for Sky Air and VRV



Graphical display of indicative electricity consumption (Function available in combination with FBA-A, FCAG and FCAHG)

A series of energy saving functions that can be individually selected

- › Demand control (1)
- › Temperature range limit
- › Setback function
- › Presence & floor sensor connection (available on round flow and fully flat cassette)
- › kWh indication (2)
- › Set temperature auto reset
- › Off timer



Cost-effective solution for infrastructure cooling applications

› Only in combination with RZAG* / RZQG*

(1) Only available on RZAG*, RZASG*, RZQG*, RZQSG*
 (2) For Sky Air FBA, FCAG and FCAHG pair combinations only

Other functions

- › Up to 3 independent schedules
- › Possibility to individually restrict menu functions
- › Choice of display between symbol or text
- › Real time clock with auto update to daylight saving time
- › Built-in backup power
- › Supports multiple languages:
 BRC1E53A: English, German, French, Dutch, Spanish, Italian, Portugese
 BRC1E53B: English, Czech, Croatia, Hungarian, Romanian, Slovenian, Bulgarian
 BRC1E53C: English, Greek, Russian, Turkish, Polish, Slovak, Albanian

BRC2E52A / BRC3E52A

Simplified wired remote control developed for hotel applications



BRC2E52C

With operation mode selector

- › Symbol driven interface for intuitive control
- › Functions restricted to basic customer needs
- › Energy saving thanks key card, window contact integration and set point limitation (BRP7A51)
- › Flexible setback function ensures room temperature remains within comfortable limits to ensure guest comfort
- › Flat backpanel for easy installation
- › Easy commissioning: intuitive interface for advanced menu settings
- › 2 versions available:
 - BRC3E52C: temperature, fan speed, ON/OFF
 - BRC2E52C: temperature, mode, fan speed, ON/OFF

BRC1D52

Wired remote control



BRC1D52

- › Schedule timer: Five day actions can be set
- › Home leave (frost protection): during absence, the indoor temperature can be maintained at a certain level. This function can also switch the unit ON/OFF
- › User friendly HRV function, thanks to the introduction of a button for ventilation mode and fan speed
- › Immediate display of fault location and condition
- › Reduction of maintenance time and costs
- › Operating mode
- › Heat Recovery Ventilation (HRV) in operation
- › Cool / heat changeover control
- › Centralised control indication
- › Group control indication
- › Set temperature
- › Air flow direction
- › Programmed time
- › Inspection test / operation
- › Fan speed
- › Clean air filter
- › Defrost / hot start
- › Malfunction

ARC4*/BRC4*/BRC7*

Infrared remote control



ARC466A1

BRC4*/BRC7*

Operation buttons: ON / OFF, timer mode start / stop, timer mode on / off, programme time, temperature setting, air flow direction (1), operating mode, fan speed control, filter sign reset (2), inspection (2) / test indication (2)

Display: Operating mode, battery change, set temperature, air flow direction (1), programmed time, fan speed, inspection / test operation (2)

1. Not applicable for FXDQ, FXSQ, FXNQ, FBDQ, FDXM, FBA
 2. For FX** units only
 3. For all features of the remote control, refer to the operation manual



ARCWLA / ARCWB

Siesta individual control systems

Overview controllers for Siesta Sky Air

Siesta Sky Air indoor units	Controllers
AHQ-C ceiling suspended	<ul style="list-style-type: none"> Standard infrared remote control in box of indoor unit ARCWLA Wired remote control ARCWB Optional group controller R04084124324
ABQ-C concealed ceiling	<ul style="list-style-type: none"> Standard wired remote control (ARCWB) in box of indoor unit Optional group controller R04084124324

Overview of features



ARCWB

Feature		ARCWB
		AHQ-C and ACQ-D / Standard for ABQ-C
1	ON/OFF switch	-
2	Temperature setting	Default range 16-30°C
		Optional range 20-30°C
		Switch between °C and °F
3	Room temperature sensor on remote control	-
4	Cool / Fan dry / Heat / Auto	-
5	Sleep mode	-
6	Fan Speed selection	-
7	Delay timer	••
8	7-days programmable timer	-
9	Real time clock display	-
10	Air swing selection	ON/OFF swing mode
		Change swing option (draft/soil prevention or standard)
11	LCD display without backlight	-
12	Key lock	-
13	Error code indication	-
14	IR receiver to enable compatibility with infrared remote control (disabled when lock function is activated)	-
15	Last state memory from indoor PCB	-
16	Silent mode	•
17	Turbo mode	•
18	Compressor test model (compressor force ON)	-
19	Daikin inverter error code	-
20	UART communication port (for Daikin protocol)	-
21	Backup battery	-

Specifications

- › Dimensions (length x width x height) ARCWB: 0.15 m x 0.21 m x 0.04 m.
- › ARCWB comes standard with a 10 metre cable, which can be extended to maximum cable length of 15 metres. ARCWB can only control one indoor unit at a time; group control is only possible when using option R04084124324.

- Standard
- By dipswitch selection
- 1, 2 & 4 hours delay

Centralised control systems

Centralised control of the Sky Air and VRV system can be achieved via 3 user friendly compact remote controllers. These controls may be used independently or in combination with 1 group = several (up to 16) indoor units in combination and 1 zone = several groups in combination.

A centralised remote control is ideal for use in tenanted commercial buildings subject to random occupation, enabling indoor units to be classified in groups per tenant (zoning).

The schedule timer programmes the schedule and operation conditions for each tenant and the control can easily be reset according to varying requirements.

DCS302C51

Centralised remote control



Providing individual control of 64 groups (zones) of indoor units.

- › a maximum of 64 groups (128 indoor units, max. 10 outdoor units) can be controlled
- › a maximum of 128 groups (128 indoor units, max. 10 outdoor units) can be controlled via 2 centralised remote controls in separate locations
- › zone control
- › group control
- › malfunction code display
- › maximum wiring length of 1,000m (total: 2,000m)
- › air flow direction and air flow rate of HRV can be controlled
- › expanded timer function

DST301B51

Schedule timer



Enabling 64 groups to be programmed.

- › a maximum of 128 indoor units can be controlled
- › 8 types of weekly schedule
- › a maximum of 48 hours back up power supply
- › a maximum wiring length of 1,000m (total: 2,000m)

DCS301B51

Unified ON/OFF control



Providing simultaneous and individual control of 16 groups of indoor units.

- › a maximum of 16 groups (128 indoor units) can be controlled
- › 2 remote controls in separate locations can be used
- › operating status indication (normal operation, alarm)
- › centralised control indication
- › maximum wiring length of 1,000m (total: 2,000m)

DTA113B51

Basic solution for control of Sky Air and VRV

- › Rotation function
- › Backup operation function.

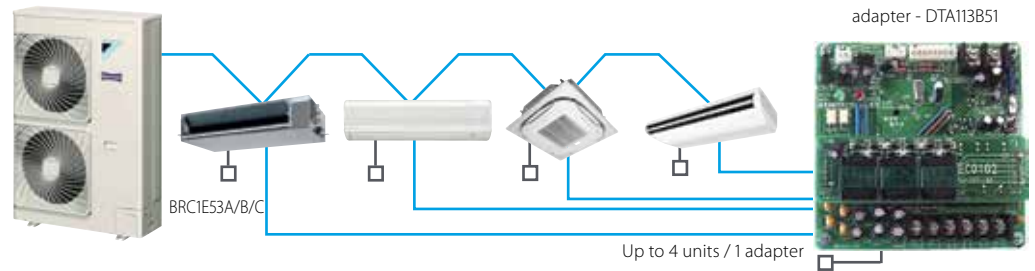

touch
intelligent Controller

DCS601C51

Detailed & easy monitoring and operation of VRV systems (max. 64 indoor units groups).

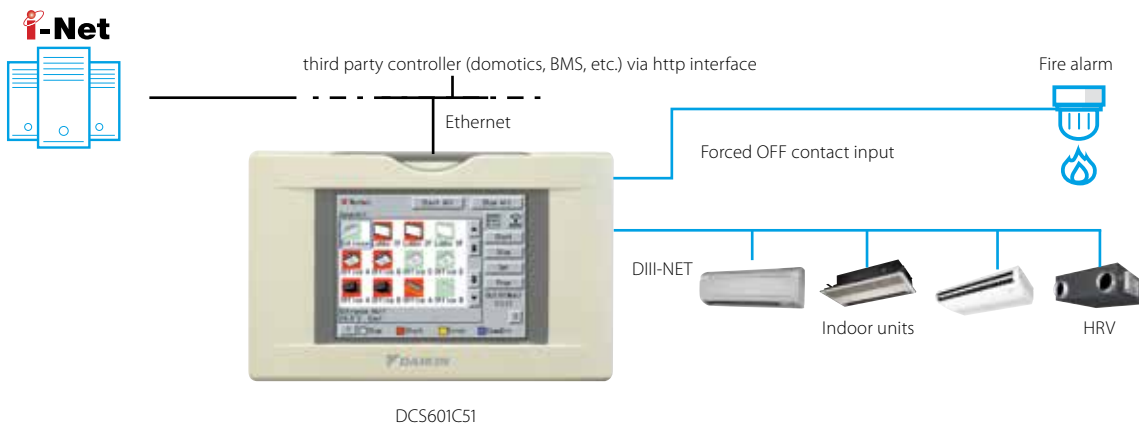

Languages

- › English
- › French
- › German
- › Italian
- › Spanish
- › Dutch
- › Portuguese

System layout

- › Up to 64 indoor units can be controlled
- › Touch panel (full colour LCD via icon display)

Control

- › Individual control (set point, start/stop, fan speed) (max. 64 groups/indoor units)
- › Set back schedule
- › Enhanced scheduling function (8 schedules, 17 patterns)
- › Flexible grouping in zones
- › Yearly schedule
- › Fire emergency stop control
- › Interlocking control
- › Increased HRV monitoring and control function
- › Automatic cooling / heating change-over
- › Heating optimization
- › Temperature limit
- › Password security: 3 levels (general, administration & service)
- › Quick selection and full control
- › Simple navigation

Monitoring

- › Visualisation via Graphical User Interface (GUI)
- › Icon colour display change function
- › Indoor units operation mode
- › Indication filter replacement
- › Multi PC

Cost performance

- › Free cooling function
- › Labour saving
- › Easy installation
- › Compact design: limited installation space
- › Overall energy saving

Open interface

- › Communication to any third party controller (domotics, BMS, etc.) is possible via open interface (http option DCS007A51)

Connectable to

- › VRV
- › HRV
- › Sky Air
- › Split (via interface adapter)

Advanced centralised controller with Cloud connection

- Intuitive and user-friendly interface
- Flexible concept for stand alone and multi site applications
- Total solution thanks to integration of 3rd party equipment
- Monitor & control your small commercial building, no matter where you are

2 solutions:

Local solution

- › Offline centralised control
- › Stylish optional screen fits any interior

Cloud solution

- › Flexible online control from any device (Laptop, tablet...)
- › Monitor & control one or multiple sites
- › Benchmark the energy consumption of different installations (1)
- › Energy consumption follow-up to comply with local regulations

System layout

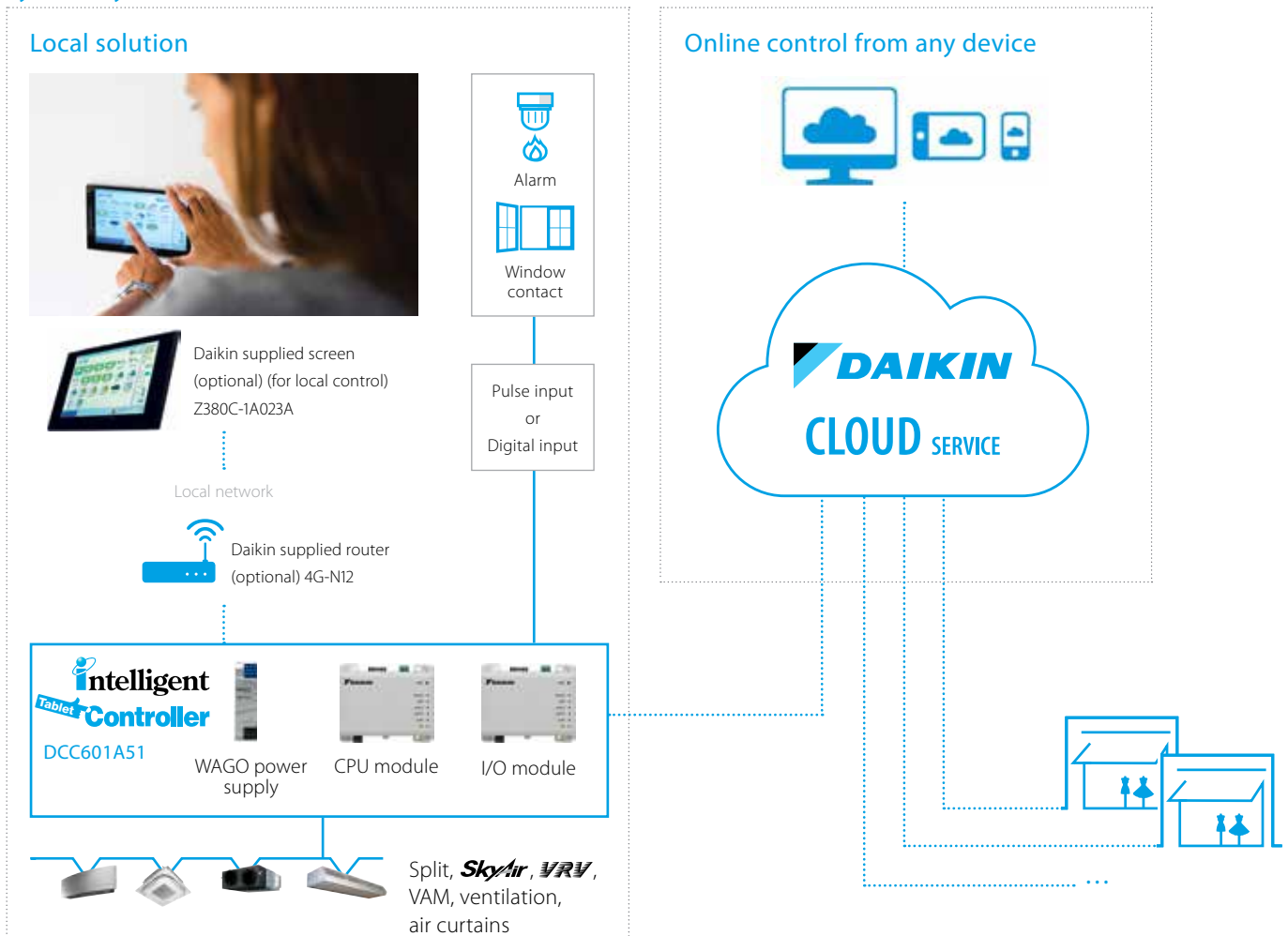

(1) For VRV

Total solution

- › Total solution thanks to a large integration of Daikin products and 3rd party equipment
- › Connect a wide range of units (Split, Sky Air, VRV, Ventilation, Biddle air curtains)
- › Simply control your entire building centrally
- › Increased customer shopping experience by better management of your shop comfort level

Daikin Cloud Services

- › Control your building no matter where you are
- › Monitor and control multiple sites
- › Installer or technical manager can remotely login to the cloud for first troubleshooting
- › Benchmark the energy consumption of different installations (1)
- › Manage & track your energy use

User friendly touch control

- › Stylish Daikin supplied optional screen for local control fits any interior
- › Intuitive and user-friendly interface
- › Full solution with simple control
- › Easy commissioning

Flexible

- › Inputs via digital and pulse input for 3rd party equipment such as kWh meters, emergency input, window contact, ...
- › Modular concept allows your cloud to grow with your business
- › Control up to 32 indoor unit (groups)

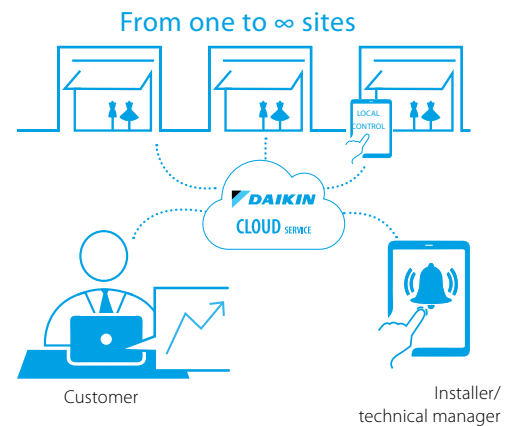

Intuitive control from the cloud



Easy follow up of energy consumption

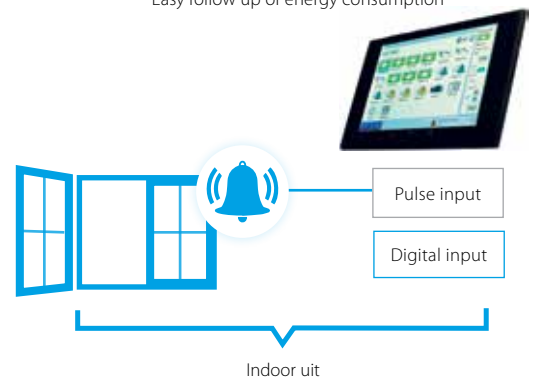

Functions overview

		Local solution	Cloud solution
Languages		Depends on local device	EN, DE, FR, NL, ES, IT, EL, PT, RU, TR, DA, SV, NO, FI, CS, HR, HU, PL, RO, SL, BG, SK
System layout	N° of connectable indoor units	32	32
	Multiple sites control		●
Monitoring & control	Basic control functions (ON/OFF, mode, filter sign, setpoint, fan speed, ventilation mode, room temperature, ...)	●	●
	Remote control prohibition	●	●
	All devices ON/OFF	●	●
	Zone control		●
	Group control	●	●
	Weekly schedule	●	●
	Yearly schedule		●
	Interlock control	●	●
	Set point limitation		●
	Visualisation of energy use per operation mode		●
Connectable to	DX split, Sky Air, VRV	●	●
	VAM, VKM ventilation	●	●
	Air curtains	●	●

For available Daikin Cloud Service options refer to the option list

Mini BMS

with full integration
across all product pillars

DCM601A51



- Price competitive mini BMS
- Cross-pillar integration of Daikin products
- Integration of third party equipment



NEW

Download the WAGO
selection tool from
my.daikin.eu

- › Easy selection of WAGO materials
- › Material list creation
- › Time saving
 - Includes wiring schemes
 - Contains commissioning/preset data for iTM



Check on
YouTube

[https://www.youtube.com/
DaikinEurope](https://www.youtube.com/DaikinEurope)

System overview

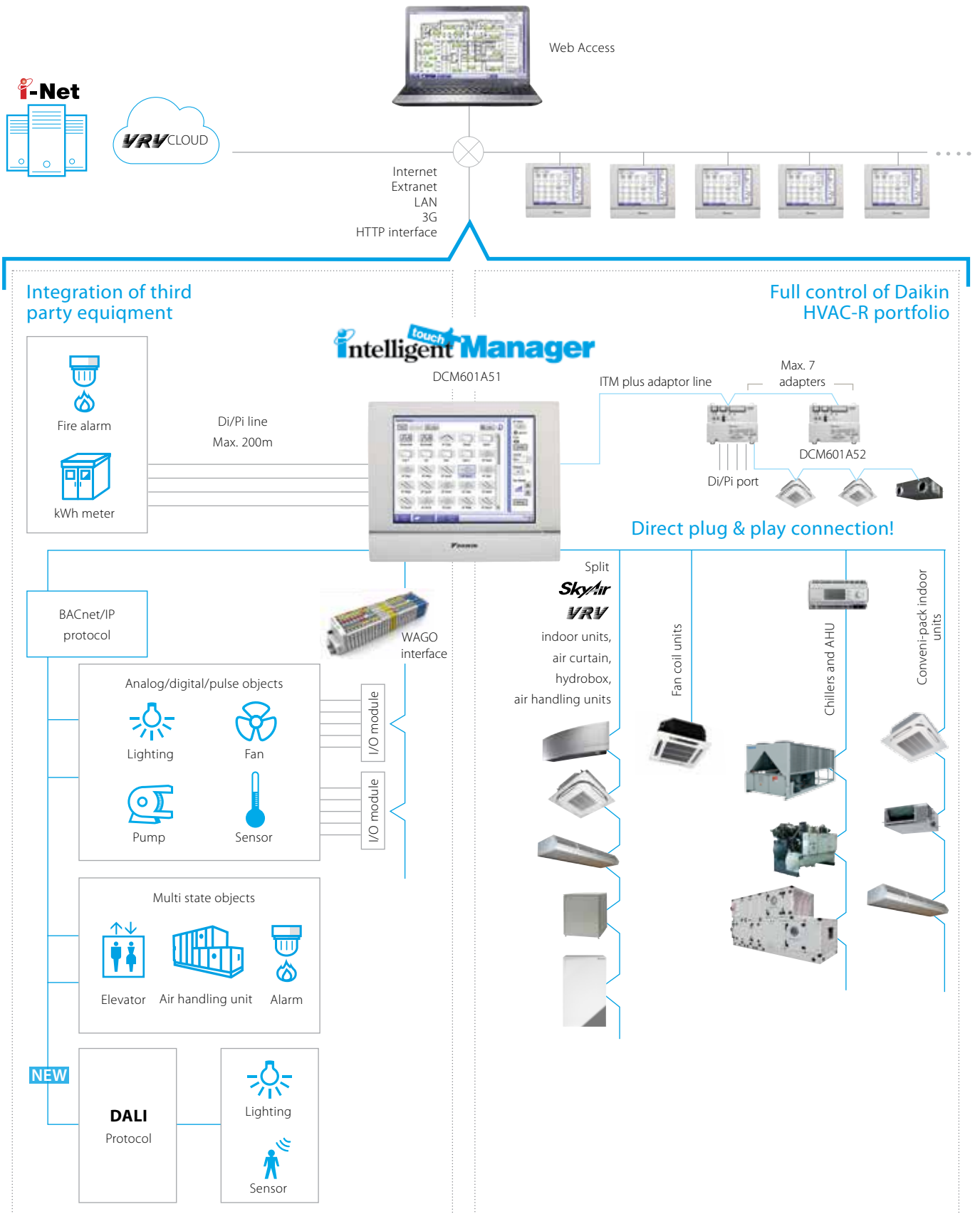



User friendliness

- › Intuitive user interface
- › Visual lay out view and direct access to indoor unit main functions
- › All functions direct accessible via touch screen or via web interface



Smart energy management

- › Monitoring if energy use is according to plan
- › Helps to detect origins of energy waste
- › Powerful schedules guarantee correct operation throughout the year
- › Save energy by interlocking A/C operation with other equipment such as heating

Flexibility

- › Cross-pillar integration (heating, air conditioning, applied systems, refrigeration, air handling units)
- › BACnet protocol for 3rd party products integration
- › I/O for integration of equipment such as lights, pumps... on WAGO modules
- › Modular concept for small to large applications
- › Control up to 512 indoor unit groups via one ITM and combine multiple ITM via web interface

Easy servicing and commissioning

- › Remote refrigerant containment check reducing on site visit
- › Simplified troubleshooting
- › Save time on commissioning thanks to the pre-commissioning tool
- › Auto registration of indoor units

Plug & play

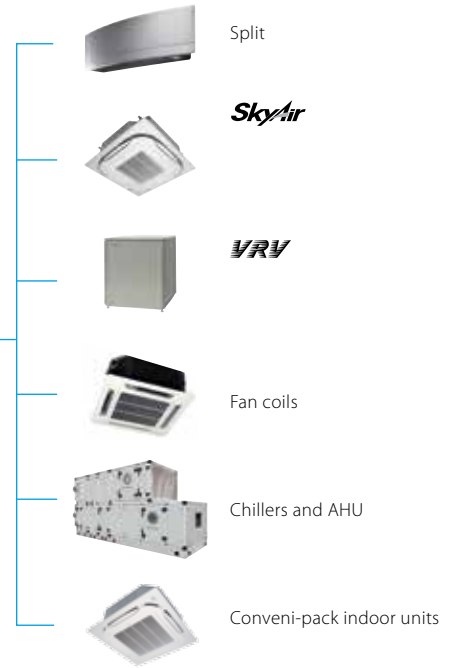

Flexibility in size
64 up to 512 groups

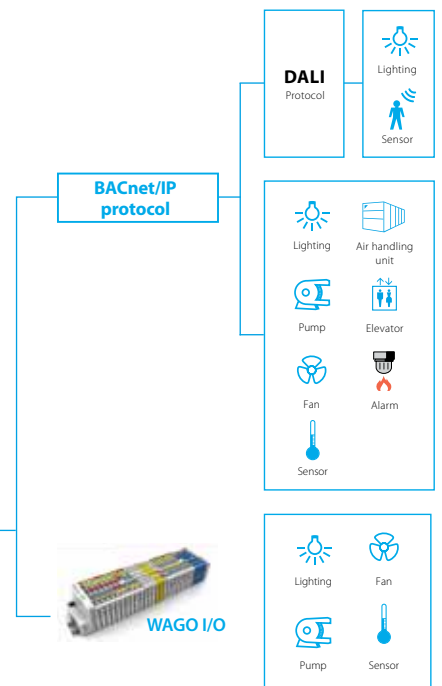

Functions overview

Languages

- › English
- › French
- › German
- › Italian
- › Spanish
- › Dutch
- › Portuguese

Management

- › Web access
- › Power Proportional Distribution (option)
- › Operational history (malfunctions, ...)
- › Smart energy management
 - monitor if energy use is according to plan
 - detect origins of energy waste
- › Setback function
- › Sliding temperature

WAGO Interface

- › Modular integration of 3rd party equipment
 - WAGO coupler (interface between WAGO and iTM)
 - Di module
 - Do module
 - Ai module
 - Ao module
 - Thermistor module
 - Pi module

Open http interface

- › Communication to any third party controller (domotics, BMS, etc.) is possible via http open interface (http option DCM007A51)

System layout

- › Up to 512 unit groups can be controlled (ITM + 7 iTM Plus adapters)

Control

- › Individual control (512 groups)
- › Schedule setting (Weekly schedule, yearly calendar, seasonal schedule)
- › Interlock control
- › Setpoint limitation
- › Temperature limit

NEW

DALI integration

- › Control and monitor the lights
- › Easier facility management: receive error signal when light or light controller has a malfunction
- › Flexible approach and less wiring needed, compared to classic light scheme
- › Easier to make groups and control scenes
- › Connection between intelligent Touch Manager and DALI through WAGO BACnet IP interface

Connectable to

- DX Split, Sky Air, VRV
- Chillers (via MT3-EKMBACIP controller)
- Daikin AHU
- Fan coils
- Daikin Altherma Flex type
- LT and HT hydroboxes
- Biddle Air curtains
- WAGO I/O
- BACnet/IP protocol



Modbus Interface

RTD

RTD-NET

- › Modbus interface for monitoring and control of Sky Air, VRV, VAM and VKM

RTD-10

- › Advanced integration into BMS of Sky Air, VRV, VAM and VKM through either:
 - Modbus
 - Voltage (0-10V)
 - Resistance
- › Duty/standby function for server rooms

RTD-20

- › Retail economisor
- › Advanced control of Sky Air, VRV, VAM/VKM and air curtains
- › Clone or independent zone control
- › Increased comfort with integration of CO₂ sensor for fresh air volume control
- › Save on running costs via
 - pre/post and trade mode
 - set point limitation
 - overall shut down
 - PIR sensor for adaptive deadband

RTD-HO

- › Modbus interface for monitoring and control of Sky Air, VRV, VAM and VKM
- › Intelligent hotel room controller

RTD-20 retail economiser

Control zones in shop applications

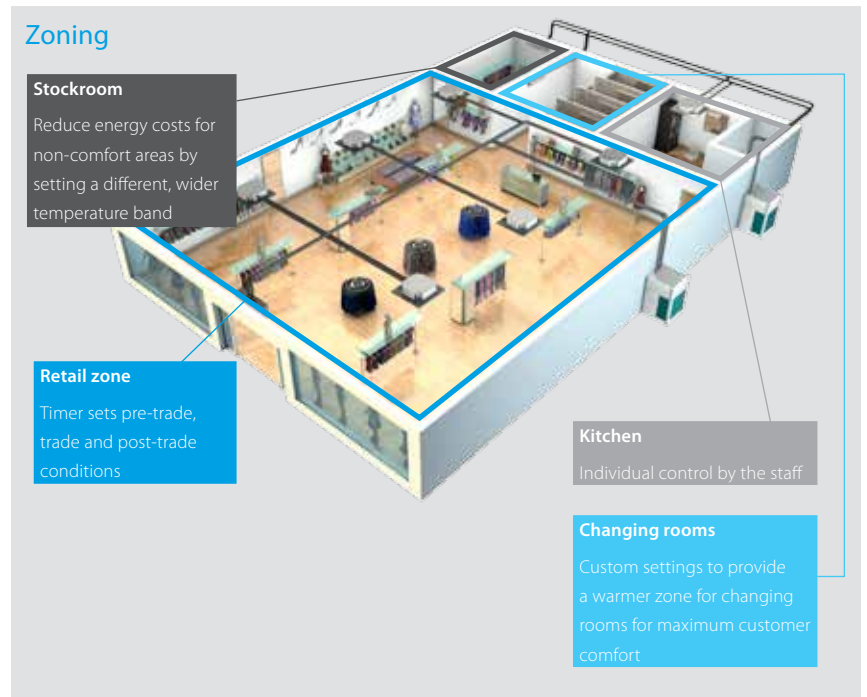

Control options benefits

Optimize the operation of the air conditioning without compromising occupant comfort

Without RTD-20

- › Pre-trade:
 - AC either on (timer) or off
 - whole store heated or cooled
- › Trading:
 - achieving set-point
 - staff could access controllers
 - heat cool clash can occur
 - door curtain not interlocked
 - always trying to achieve set-point
- › Post-Trade:
 - either on or off

With RTD-20

- › Pre-trade:
 - De-stratification on start-up
 - Heat/Cool protection enabled
 - AC only comes on if internal temp above 26°C or below 19°C
 - achieving midpoint of 19-23°C
 - controllers locked
 - heat cool clash prevented
 - door curtain interlocked
 - learns store patterns & heats/cools "enough" to reach set-point
- › Post-Trade:
 - Heat/cool protection enabled
 - Trade extension function

Integrate all essential store operations in one control

Optimize the operation of the air conditioning without compromising occupant comfort.

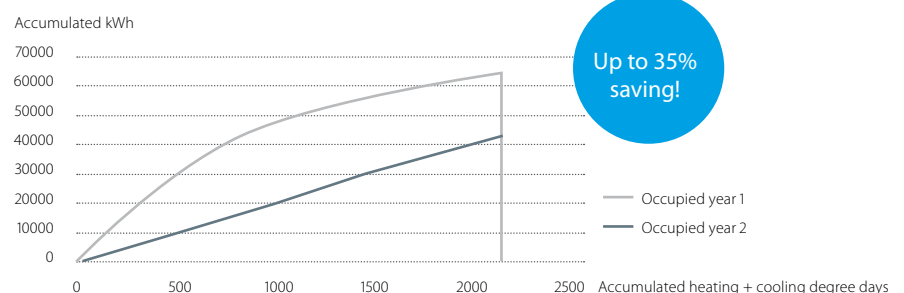

Up to 35% saving!

Overview functions



Main functions	RTD-NET	RTD-10	RTD-20	RTD-HO
Dimensions H x W x D mm	100 x 100 x 22			
Key card + window contact				✓
Set back function				✓
Prohibit or restrict remote control functions (setpoint limitation, ...)	✓	✓	✓**	✓
Modbus (RS485)	✓	✓	✓	✓
Group control	✓	✓	✓	✓
0 - 10 V control		✓	✓	
Resistance control		✓	✓	
IT application		✓		
Heating interlock		✓	✓	
Output signal (on/defrost, error)		✓	✓****	✓
Retail application			✓	
Partitioned room control			✓	
Air curtain	✓***	✓***	✓	

(!): By combining RTD-RA devices

Control functions	RTD-NET	RTD-10	RTD-20	RTD-HO
On/Off	M	M,V,R	M	M*
Set point	M	M,V,R	M	M*
Mode	M	M,V,R	M	M*
fan	M	M,V,R	M	M*
Louver	M	M,V,R	M	M*
HRV Damper control	M	M,V,R	M	
Prohibit/Restrict functions	M	M,V,R	M	M*
Forced thermo off				

Monitoring functions	RTD-NET	RTD-10	RTD-20	RTD-HO
On/Off	M	M	M	M
Set point	M	M	M	M
Mode	M	M	M	M
fan	M	M	M	M
Louver	M	M	M	M
RC temperature	M	M	M	M
RC mode	M	M	M	M
nbr units	M	M	M	M
Fault	M	M	M	M
Fault code	M	M	M	M
Return air temperature (Average /Min/Max)	M	M	M	M
Filter alarm	M	M	M	M
Thermo on	M	M	M	M
Defrost	M	M	M	M
Coil In/Out temperature	M	M	M	M

M : Modbus / R : Resistance / V : Voltage / C: control
 * : only when room is occupied / ** : setpoint limitation / (*) if available
 *** : no fan speed control on the CYV air curtain / **** : run & fault

Modbus Interface

RTD

RTD-NET

- › Modbus interface for monitoring and control of Sky Air, VRV, VAM and VKM

RTD-10

- › Advanced integration into BMS of Sky Air, VRV, VAM and VKM through either:
 - Modbus
 - Voltage (0-10V)
 - Resistance
- › Duty/standby function for server rooms

RTD-20

- › Retail economisor
- › Advanced control of Sky Air, VRV, VAM/VKM and air curtains
- › Clone or independent zone control
- › Increased comfort with integration of CO₂ sensor for fresh air volume control
- › Save on running costs via
 - pre/post and trade mode
 - set point limitation
 - overall shut down
 - PIR sensor for adaptive deadband

RTD-HO

- › Modbus interface for monitoring and control of Sky Air, VRV, VAM and VKM
- › Intelligent hotel room controller

RTD-20 retail economiser

Control zones in shop applications

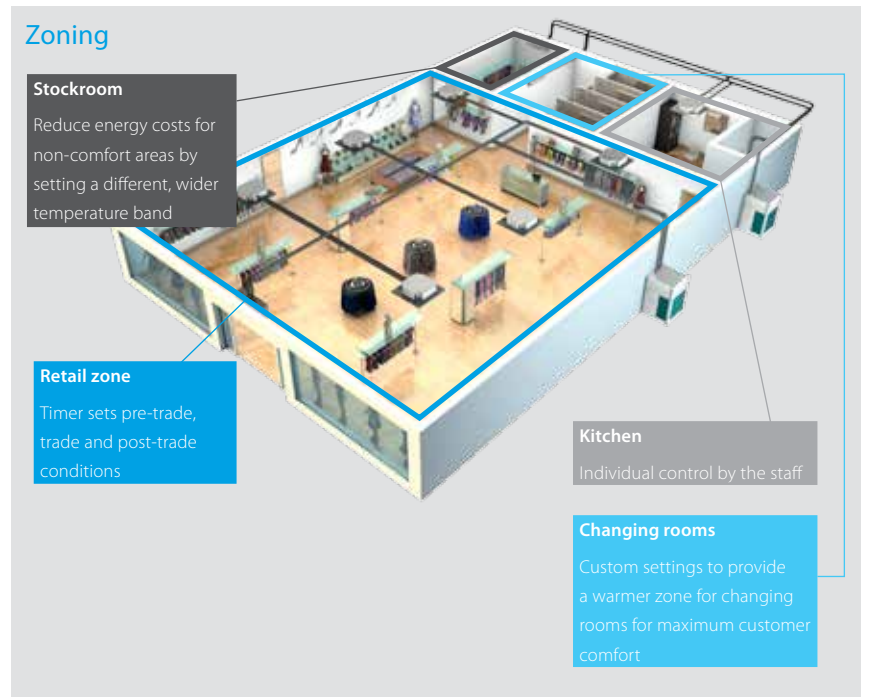

Control options benefits

Optimize the operation of the air conditioning without compromising occupant comfort

Without RTD-20

- › Pre-trade:
 - AC either on (timer) or off
 - whole store heated or cooled
- › Trading:
 - achieving set-point
 - staff could access controllers
 - heat cool clash can occur
 - door curtain not interlocked
 - always trying to achieve set-point
- › Post-Trade:
 - either on or off

With RTD-20

- › Pre-trade:
 - De-stratification on start-up
 - Heat/Cool protection enabled
 - AC only comes on if internal temp above 26°C or below 19°C
 - achieving midpoint of 19-23°C
 - controllers locked
 - heat cool clash prevented
 - door curtain interlocked
 - learns store patterns & heats/cools "enough" to reach set-point
- › Post-Trade:
 - Heat/cool protection enabled
 - Trade extension function

Integrate all essential store operations in one control

Optimize the operation of the air conditioning without compromising occupant comfort.

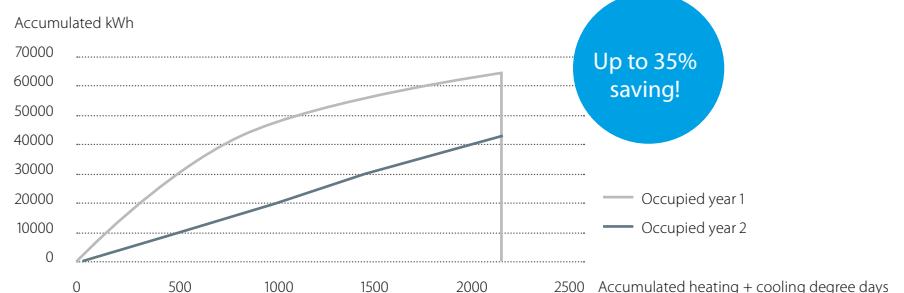

Up to 35% saving!

Overview functions



Main functions	RTD-NET	RTD-10	RTD-20	RTD-HO
Dimensions H x W x D mm	100 x 100 x 22			
Key card + window contact				✓
Set back function				✓
Prohibit or restrict remote control functions (setpoint limitation, ...)	✓	✓	✓**	✓
Modbus (RS485)	✓	✓	✓	✓
Group control	✓	✓	✓	✓
0 - 10 V control		✓	✓	
Resistance control		✓	✓	
IT application		✓		
Heating interlock		✓	✓	
Output signal (on/defrost, error)		✓	✓****	✓
Retail application			✓	
Partitioned room control			✓	
Air curtain	✓**	✓**	✓	

(!): By combining RTD-RA devices

Control functions	RTD-NET	RTD-10	RTD-20	RTD-HO
On/Off	M	M,V,R	M	M*
Set point	M	M,V,R	M	M*
Mode	M	M,V,R	M	M*
fan	M	M,V,R	M	M*
Louver	M	M,V,R	M	M*
HRV Damper control	M	M,V,R	M	
Prohibit/Restrict functions	M	M,V,R	M	M*
Forced thermo off				

Monitoring functions	RTD-NET	RTD-10	RTD-20	RTD-HO
On/Off	M	M	M	M
Set point	M	M	M	M
Mode	M	M	M	M
fan	M	M	M	M
Louver	M	M	M	M
RC temperature	M	M	M	M
RC mode	M	M	M	M
nbr units	M	M	M	M
Fault	M	M	M	M
Fault code	M	M	M	M
Return air temperature (Average /Min/Max)	M	M	M	M
Filter alarm	M	M	M	M
Thermo on	M	M	M	M
Defrost	M	M	M	M
Coil In/Out temperature	M	M	M	M

M : Modbus / R : Resistance / V : Voltage / C: control
 * : only when room is occupied / ** : setpoint limitation / (*) if available
 *** : no fan speed control on the CYV air curtain / **** : run & fault

DIII-net Modbus interface

EKMBDXA

Integrated control system for seamless connection between Split, Sky Air, VRV and small inverter chillers and BMS systems

- > Communication via Modbus RS485 protocol
- > Detailed monitoring and control of the VRV total solution
- > Easy and fast installation via DIII-net protocol
- > As the Daikin DIII-net protocol is being used, only one modbus interface is needed for a group of Daikin systems (up to 10 outdoor unit systems).

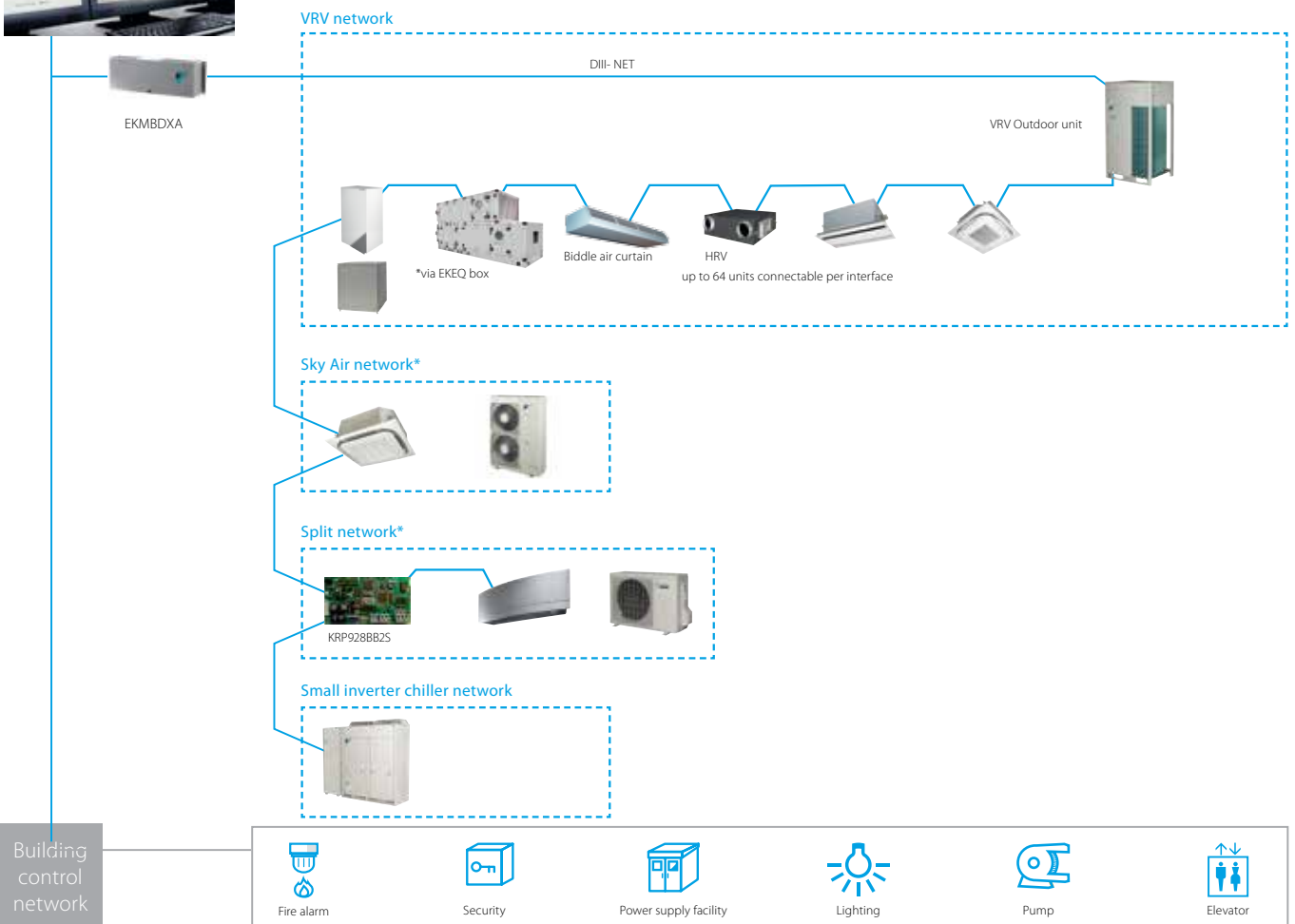

* Additional centralized controller might be required. For more information contact your local dealer.

		EKMBDXA7V1	
Maximum number of connectable indoor units			64
Maximum number of connectable outdoor units			10
Communication	DIII-NET - Remark		DIII-NET (F1F2)
	Protocol - Remark		2 wire; communication speed: 9600 bps or 19200 bps
	Protocol - Type		RS485 (modbus)
	Protocol - Max. Wiring length	m	
Dimensions	HeightxWidthxDepth	mm	124x379x87
Weight		kg	2.1
Ambient temperature - operation	Max.	°C	60
	Min.	°C	0
Installation			Indoor installation
Power supply	Frequency	Hz	50
	Voltage	V	220-240

KNX interface

KLIC-DI

Integration of Sky Air and VRV in HA/BMS systems

Connect Sky Air / VRV indoor units to KNX interface for BMS integration

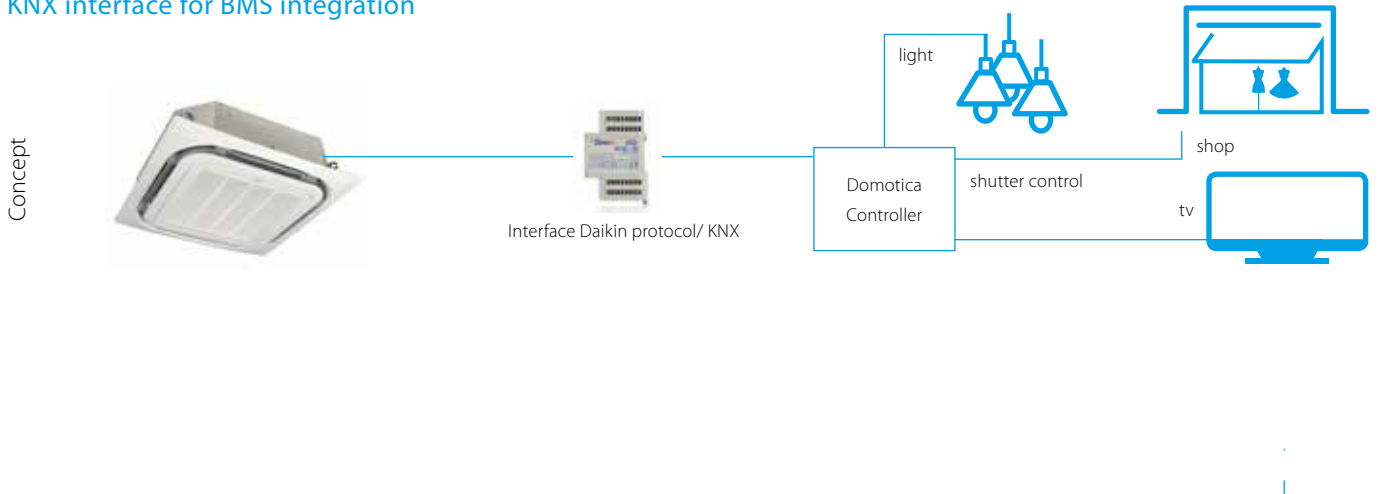

KNX interface line-up

The integration of Daikin indoor units through the KNX interface allows monitoring and control of several devices, such as lights and shutters, from one central controller. One particularly important feature is the ability to programme a 'scenario' - such as "Home leave" - in which the end-user selects

a range of commands to be executed simultaneously once the scenario is selected. For instance in "Home leave", the air conditioner is off, the lights are turned off, the shutters are closed and the alarm is on.

KNX interface for

	 KLIC-DI Size 90x60x35mm	
	Sky Air	VRV
Basic control		
On/Off	●	●
Mode	Auto, heat, dry, fan, cool	Auto, heat, dry, fan, cool
Temperature	●	●
Fan speed levels	2 or 3	2 or 3
Swing	Stop or movement	Swing or fixed positions (5)
Advanced functionalities		
Error management	Communication errors, Daikin unit errors	
Scenes	●	●
Auto switch off	●	●
Temperature limitation	●	●
Initial configuration	●	●
Master and slave configuration	●	●

Wireless room temperature sensor

K.RSS



Flexible and easy installation

- › Accurate temperature measurement thanks to flexible placement of the sensor
- › No need for wiring
- › No need to drill holes
- › Ideal for refurbishment

Connection diagram Daikin indoor unit PCB (FXSQ example)

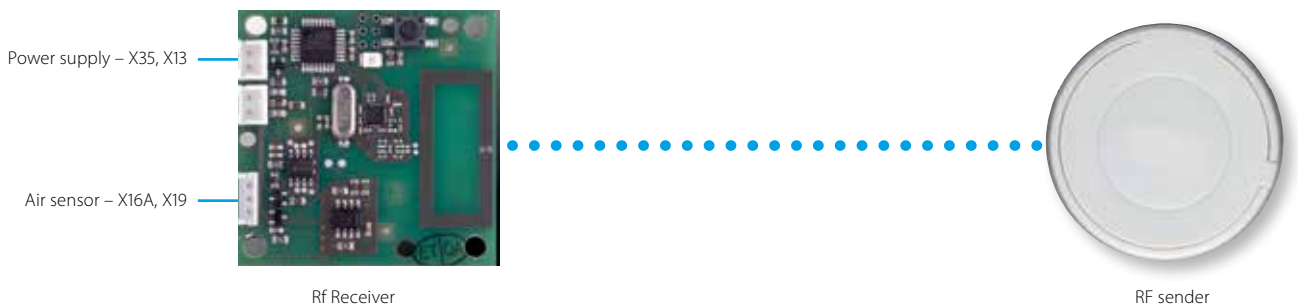

Specifications

				Wireless room temperature sensor kit (K.RSS)	
				Wireless room temperature receiver	Wireless room temperature sensor
Dimensions	mm	50 x 50		ø 75	
Weight	g	40		60	
Power supply		16VDC, max. 20 mA		N/A	
Battery life		N/A		+/- 3 years	
Battery type		N/A		3 Volt Lithium battery	
Maximum range	m	10			
Operation range	°C	0~50			
Communication	Type	RF			
	Frequency	MHz	868.3		

- › Room temperature is sent to the indoor unit every 90 seconds or if the temperature difference is 0.2°C or larger.

Wired room temperature sensor

KRCS01-1B
KRCS01-4B



- › Accurate temperature measurement, thanks to flexible placement of the sensor











Specifications

Dimensions (HxW)	mm	60 x 50
Weight	g	300
Length of branch wiring	m	12

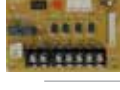
ADAPTER PCBs



Simple solutions for unique requirements Concept and benefits

- › Low cost option to satisfy simple control requirements
- › Deployed on single or multiple units

			Connectable to:		
			Split	Sky Air	VRV
	(E)KRP1B* adapter for wiring	<ul style="list-style-type: none"> Facilitates integration of auxiliary heating apparatus, humidifiers, fans, damper Powered by and installed at the indoor unit 		●	●
	KRP2A*/KRP4A* Wiring adapter for electrical appendices	<ul style="list-style-type: none"> Remotely start and stop up to 16 indoor units (1 group) (KRP2A* via P1 P2) Remotely start and stop up to 128 indoor units (64 groups) (KRP4A* via F1 F2) Alarm indication/ fire shut down Remote temperature setpoint adjustment Cannot be used in combination with a central controller 		●	●
	KRP58M3	<ul style="list-style-type: none"> Low noise and demand control option for RZQ200/250C 		●	
	SB.KRP58M51	<ul style="list-style-type: none"> Low noise and demand control option for RZQG and RZQSG single phase Includes mounting plate EKMKA1 		●	
	KRP58M51	<ul style="list-style-type: none"> Low noise and demand control option for RZQG1 and RZQSG 3 phase 		●	
	DTA104A* Outdoor Unit External Control Adapter	<ul style="list-style-type: none"> Individual or simultaneous control of VRV system operating mode Demand control of individual or multiple systems Low noise option for individual or multiple systems 			●
	DCS302A52 Unification adapter for computerized control	<ul style="list-style-type: none"> Enables unified display (operation/malfunction) and unified control (ON/OFF) from BMS system Must be used together with Intelligent Touch Controller or intelligent Touch Manager Cannot be combined with KRP2/4* Can be used for all VRV indoor models 			●
	KRP928* Interface adapter for DIII-net	<ul style="list-style-type: none"> Allows integration of split units to Daikin central controls 	●		
	KRP413* Wiring adapter normal open contact / normal open pulse contact	<ul style="list-style-type: none"> Switch off auto restart after power failure Indication of operation mode / error Remotely start /stop Remotely change operation mode Remotely change fan speed 	●		
	KRP980* Adapter for split units without an S21 port	<ul style="list-style-type: none"> Connect a wired remote control Connect to Daikin central controls Allow external contact 	●		

Some adapters require an installation box, refer to the option lists for more information

Accessories

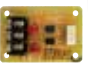
EKRORO		<ul style="list-style-type: none"> External ON/OFF or forced off Example: door or window contact
EKRORO 3		<ul style="list-style-type: none"> External ON/OFF or forced off F1/F2 contact Example: door or window contact
KRC19-26A		<ul style="list-style-type: none"> Mechanical cool/heat selector Allows switching over an entire system between cooling/heating/fan only Connects to the A/B/C terminals of the unit
BRP2A81		<ul style="list-style-type: none"> Cool/heat selector PCB Required to connect KRC19-26A to a VRV IV outdoor unit

AUTO-CLEANING PANEL



FILTERS



INTELLIGENT SENSORS

Options & accessories

Sky Air 156

Indoor units 156
Outdoor units 258

Ventilation 160

Air handling units 161

INDOOR UNITS		FCAHG-G FCAG-A	FFA-A	FDBQ-B	FDXM-F3	FBA-A	FDA-A	
Panels	Decoration panel (obligatory for cassette units, optional for others)	BYCQ140D (standard) BYCQ140DW (white)(1) BYCQ140DG9/ BYCQ140DGF9 (auto-cleaning)(2)(4)	BYFQ60CW (white) BYFQ60CS (silver) BYFQ60B3 (standard)					
	Panel spacer for reducing required installation height		KDBQ44B60 (only for standard panel)					
	Sealing kit for 3- or 2-directional air discharge	KDBHQ55B140 (11)	BDBHQ44C60					
	Sensor kit	BRYQ140A	BRYQ60AW (white)(9) BRYQ60AS (silver)(9)					
Individual control systems	BRP069A81 - Online Controller	•	•		•	•	•	
	Infrared remote control (incl. receiver)	BRC7FA532F (11)	BRC7EB530W for standard panel (5)(6) BRC7F530W for white panel (5)(6) BRC7F530S - for silver panel (5)(6)		BRC4C65	BRC4C65	BRC4C65	
	BRC1H51W (Glossy white) / BRC1H51S (Metallic silver) / BRC1H51K (Black matte) - User-friendly wired remote controller with premium design	•	•	•	•	•	•	
	BRC1E53A/B/C (3) (13) - Wired remote control with full-text interface and back-light	•	•	•	•	•	•	
	BRC1D52 (13) - Standard wired remote control with weekly timer	•	•	•	•	•	•	
	BRC2E52C (3) (13) - Simplified remote control (with operation mode selector button)	•	•	•	•	•	•	
	BRC3E52C (3) (13) - Simplified remote control (without operation mode selector button)	•	•	•	•	•	•	
	ARCWB - Wired remote controller							
	DIII-net connection - for connection to centralized control	standard	standard		standard	standard	standard	
	DCC601A51 - Intelligent tablet controller	•	•	•	•	•	•	
Centralised control systems	DCS601C51 (13) - Intelligent touch controller	•	•	•	•	•	•	
	DCS302C51 (13) - Central remote control	•	•	•	•	•	•	
	DCS301B51 (13) - Unified ON/OFF control	•	•	•	•	•	•	
	DST301B51 (13) - Schedule timer	•	•	•	•	•	•	
	NIM03 - R04084124324 - Option PCB for group control							
	Building Management System & Standard protocol interface	DCM601A51 - Intelligent Touch Manager	•	•	•	•	•	•
		RTD-NET - Modbus interface for monitoring and control	•	•	•	•	•	•
		RTD-10 - Modbus interface for infrastructure cooling	•	•	•	•	•	•
		RTD-20 - Modbus interface for retail	•	•	•	•	•	•
		RTD-HO - Modbus interface for hotel	•	•	•	•	•	•
EKMBDXA - Modbus interface		•	•	•	•	•	•	
KLIC-DI - KNX Interface		•	•	•	•	•	•	
DCM010A51 - Daikin PMS interface		•	•	•	•	•	•	
DMS502A51 - BACnet interface		•	•	•	•	•	•	
DMS504B51 - LonWorks Interface		•	•	•	•	•	•	
Filters	Replacement long-life filter, non-woven type	KAFP551K160	KAFQ441BA60					
	Auto cleaning filter	see deco panel			BAE20A62 (25 - 35) BAE20A102 (50 - 60)			
Adapter	Wiring adapter for external monitoring/control via dry contacts and setpoint control via 0-140 Ω	KRP4A53 (10)(11)	KRP4A53 (10)		KRP4A54 (10)	KRP4A52 (10)		
	Wiring adapter with 2 output signals (compressor/ Error, Fan output)	KRP1B57 (10)(11)	KRP1B57 (10)		KRP1B56 (10)			
	Wiring adapter for external central monitoring/control (controls 1 entire system)				KRP2A53 (10)	KRP2A51 (7)(10)	KRP2A51 (8)	
	Adapter for wiring (interlock for fresh air intake fan)					KRP1B54	KRP1C64 (7)	
	Wiring adapter with 4 output signals (compressor / Error, Fan, Aux, heater, Humidifier output)	EKRP1C11 (10)(11)	EKRP1B2	EKRP1B2		EKRP1B2 (7)	EKRP1B2 (7)	
	Adapter for keycard or window contact connection (in combination with BRC1H*, BRC1/2/3E* only)	BRP7A53	BRP7A53	BRP7A53	BRP7A54 (10)	BRP7A51 (12)	BRP7A54 (12)	
	Installation box/Mounting plate for adapter PCBs (when there is no space in the switchbox, an installation box is required)	KRP1H98 (11)	KRP1B101/KRP1BA101		KRP1BA101	KRP1B101/KRP1BA101	KRP4A96	
	External wired temperature sensor	KRCS01-4	KRCS01-4	KRCS01-1	KRCS01-4	KRCS01-4	KRCS01-4	
	K.RSS - External wireless temperature sensor	•	•	•		•	•	
	Remote ON/OFF, forced OFF kit	standard	standard	standard	standard	standard	EKRORO3	
Others	DTA112B51 - Interface adapter for Sky Air						•	
	Drain pump kit							
	Multi zoning kit (for detailed model code overview refer to multizoning argue card in this catalogue)				2 dampers (25 - 35) 3 dampers (25 - 35) 4 dampers (50) 5 dampers (60)	2 dampers (35 - 50) 3 dampers (35 - 50) 4 dampers (35 - 71) 5 dampers (60 - 140) 6 dampers (60 - 140) 7 dampers (100 - 140) 8 dampers (100 - 140)		
	L-type piping kit (upward direction)							
	Fresh air intake kit (direct installation type)	KDDQ55B140-1 + KDDQ55B140-2 (11)	KDDQ44XA60					
Air discharge adapter for round duct					KDAP25A56A (35-50) KDAP25A71A (60-71) KDAP25A140A (100-140)	KDAJ25K140A		

(1) Dirt formation is more easily visible on white insulation. It is recommended not to install this option in environments with a high concentration of dirt.
 (2) To be able to control option BYCQ140DG(F)9, controller BRC1H*, BRC1E* is needed. These options cannot be combined with RXYSQ*, multi or non-inverter split units

(3) Included languages are:
 A: English, German, French, Dutch, Spanish, Italian and Portuguese
 B: English, Bulgarian, Croatian, Czech, Hungarian, Romanian and Slovenian
 C: English, Greek, Polish, Russian, Albanian, Slovak and Turkish (in case of BRC2/3E52C Serbian is available instead of Albanian)
 For BRC2/3E52C use PC cable EKPCCAB3 in combination with the updater PC software to change to language pack B or C

		R-32						
		RZAG-MV1/MY1	RZASG-MV1/MY1	AZAS-MV1/MY1				
Refrigerant branch piping	for twin	KHRQ22M20TA	KHRQ22M20TA					
	for triple	KHRQ127H (100 - 140)	KHRQ127H (100 - 140)					
	for double twin	KHRQ22M20TA (3x) (125 - 140)	KHRQ22M20TA (3x) (125 - 140)					
Demand adapter kit		SB.KRP58M52	SB.KRP58M52	SB.KRP58M52				
Bottom plate heater		EKBH140L7						
		R-410A						
		RZQG-L9V1	RZQG-L(8)Y1	RZQSG-L3V1	RZQSG-L(8)Y1	AZQS-B8V1	AZQS-BY1	RZQ-C
Drain plug								KWC26B280
Refrigerant branch	For twin	KHRQ22M20TA	KHRQ22M20TA (KHRQ58T) (1)	KHRQ22M20TA	KHRQ22M20TA (KHRQ58T) (1)			KHRQ22M20TA
	For triple	KHRQ127H (100 - 140)	KHRQ127H (100 - 140) (KHRQ58H) (1)	KHRQ127H (100 - 140)	KHRQ127H (100 - 140) (KHRQ58H) (1)			KHRQ250H7
	For double twin	KHRQ22M20TA (x3) (125 - 140)	KHRQ22M20TA (x3) (125 - 140) (KHRQ58T) (1)	KHRQ22M20TA (x3) (125 - 140)	KHRQ22M20TA (x3) (125 - 140) (KHRQ58T) (1)			KHRQ22M20TA (x3)
Demand adapter kit		SB.KRP58M51	KRP58M51	KRP58M51 (71) SB.KRP58M51 (100 - 125 - 140)	KRP58M51	KRP58M51 (71) SB.KRP58M51 (100-140)	KRP58M51	KRP58M51
Bottom plate heater		EKBPH140L7	EKBPH140L7 (2)					

(1) For RZQG-L(8)Y1 in combination with FCAG35-71* or FCAHG-* use refrigerant branch piping between brackets

(2) For combination of RZQG71 and EKBPH140L7 the demand adapter kit is needed in order to connect the bottom plate heater



Ventilation

		VAM 150FC	VAM 250FC	VAM 350FC	VAM 500FC	VAM 650FC	VAM 800FC	VAM 1000FC	VAM 1500FC	VAM 2000FC
Dust filters	EN779 Medium M6	-	-	EKAFV50F6	EKAFV50F6	EKAFV80F6	EKAFV80F6	EKAFV100F6	EKAFV100F6 x2	EKAFV100F6 x2
	EN779 Fine F7	-	-	EKAFV50F7	EKAFV50F7	EKAFV80F7	EKAFV80F7	EKAFV100F7	EKAFV100F7 x2	EKAFV100F7 x2
	EN779 Fine F8	-	-	EKAFV50F8	EKAFV50F8	EKAFV80F8	EKAFV80F8	EKAFV100F8	EKAFV100F8 x2	EKAFV100F8 x2
Silencer	Model name	-	-	-	KDDM24B50	KDDM24B100	KDDM24B100	KDDM24B100	KDDM24B100 x2	KDDM24B100 x2
	Nominal pipe Diameter (mm)	-	-	-	200	200	250	250	250	250
CO ₂ sensor		-	-	BRYMA65	BRYMA65	BRYMA65	BRYMA100	BRYMA100	BRYMA200	BRYMA200
VH electrical heater for VAM		VH1B	VH2B	VH2B	VH3B	VH3B	VH4B / VH4/AB	VH4B / VH4/AB	VH5B	VH5B

Individual control systems	VAM-FC	EKEQFCBA ²	EKEQDCB ²	EKEQMCBA ²
Wired remote control	BRC1E52A/B / BRC1D52	BRC1E52A/B / BRC1D52	BRC1E52A/B / BRC1D52 1	BRC1E52A/B / BRC1D52 1
VAM wired remote control	BRC301B61	-	-	-

Centralised control systems	VAM-FC	EKEQFCBA ²	EKEQDCB ²	EKEQMCBA ²
Centralised remote control	DCS302C51	-	-	-
Unified ON/OFF control	DCS301B51	-	-	-
Schedule timer	DST301B51	-	-	-
DCC601A51	DCC601A51	-	-	-
Intelligent Touch Manager	DCM601A51	DCM601A51	DCM601A51	DCM601A51
Modbus DIII adapter	EKMBDXA7V1	EKMBDXA7V1	EKMBDXA7V1	EKMBDXA7V1
BACnet interface	DMS502A51	-	-	-
LonWorks interface	DMS504B51	-	-	-

Others	VAM150-250FC	VAM350-2000FC	EKEQFCBA ²	EKEQDCB ²	EKEQMCBA ²
Wiring adapter for electrical appendices (note 7)	KRP2A51	KRP2A51 (note 3)	-	-	-
Adapter PCB for humidifier	KRP50-2	KRP1C4 (note 4/6)	-	-	-
Adapter PCB for 3rd party heater	BRP4A50	BRP4A50A (note 4/5)	-	-	-
Remote sensor	-	-	-	KRCS01-1	-

Notes

- (1) Cool/heat selector required for operation
- (2) Unless otherwise specified DIII-net devices cannot be connected to the system
- (3) Installation box KRP1BA101 needed.
- (4) Fixing plate EKMPVAM additionally needed for VAM1500-2000FB.
- (5) 3rd party heater and 3rd party humidifier cannot be combined
- (6) Installation box KRP50-2A90 needed.
- (7) For external control and monitoring (ON/OFF control, operation signal, error indication)

VH electrical heater for VAM	
Supply voltage	220/250V ac 50/60 Hz. +/-10%
Output current (maximum)	19A at 40°C (ambient)
Temperature sensor	5k ohms at 25°C (table 502 IT)
Temperature control range	0 to 40°C / (0-10V 0-100%)
Run on timer	Adjustable from 1 to 2 minutes (factory set at 1.5 minutes)
Control fuse	20 X5 mm 250 m A
LED indicators	Power ON - Yellow Heater ON - Red (solid or flashing, indicating pulsed control) Airflow fault - Red
Mounting holes	98mm X 181mm centres 5 mm ø holes
Maximum ambient adjacent to terminal box	35°C (during operation)
Auto high temp. cutout	100°C Pre-set
Man. reset high temp. cutout	125°C Pre-set
Run relay	1A 120V AC or 1A 24V DC
BMS setpoint input	0-10VDC

Vh electrical heater for vam		vH1B	VH2B	VH3B	VH4B	VH4/AB	VH5B
Capacity	kW	1	1	1	1.5	2.5	2.5
Duct diameter	mm	100	150	200	250	250	350
Connectable VAM		VAM150FC	VAM250FC	VAM500FC	VAM800FC	VAM800FC	VAM1500FC
		-	VAM350FC	VAM650FC	VAM1000FC	VAM1000FC	VAM2000FC

D-AHU Professional

Construction type		SP 65	SP 45	FP 50	FP 25
Profile	Aluminium	standard	standard	standard	standard
	Anodized aluminium	option	option	option	option
	Aluminium with thermal break	option	option	option	option
	Anodized aluminium with thermal break	option	option	option	option
Corner	Glass fibre reinforced nylon	standard	standard	standard	standard
Panel insulation	Polyurethane foam density 45 kg/m ³ thermal conductivity 0.020 W/m*K fire reaction class 1	standard	standard	standard	standard
	Mineral wool density 90 kg/m ³ thermal conductivity 0.037 W/m*K (referred to 20°C) fire reaction class 0	option	option	option	option
External sheet material	Grey Plastisol covered galvanized steel	standard	standard	standard	standard
	Pre-coated galvanized steel	option	option	option	option
	Galvanized steel	option	option	option	option
	Aluminium	option	option	option	option
	AISI 304 stainless steel	option	option	option	option
Internal sheet material	Galvanized steel	standard	standard	standard	standard
	Pre-coated galvanized steel	option	option	option	option
	Grey Plastisol covered galvanized steel	option	option	option	option
	Aluminium	option	option	option	option
Base frame	AISI 304 stainless steel	option	option	option	option
	Aluminium	standard (from size 1 to size 17)	standard (from size 1 to size 17)	standard (from size 1 to size 17)	standard (from size 1 to size 17)
	Galvanized steel	standard (from size 18 to size 27)	standard (from size 18 to size 27)	standard (from size 18 to size 27)	standard (from size 18 to size 27)
Handle	Glass fibre reinforced nylon	standard	standard	standard	standard
	Compression type	standard	standard	standard	standard
Type	Hinge function type (possibility to remove door)	option	option	option	option

D-AHU Easy

Construction type		DS 50	DS 25
Profile	Aluminium	Standard	Standard
Corner	Glass fibre reinforced nylon	Standard	Standard
Panel insulation	Polyurethane foam thermal conductivity 0.024 W/m*K	Standard (density 45 kg/m ³)	standard (density 47 kg/m ³)
External sheet material	Pre-coated galvanized steel (RAL 9002)	Standard	Standard
Internal sheet material	Galvanized steel	Standard	Standard
Base frame	Aluminium	Standard	Standard
Handle	Glass fibre reinforced nylon	Standard	Standard
Type	Compression type	Standard	Standard

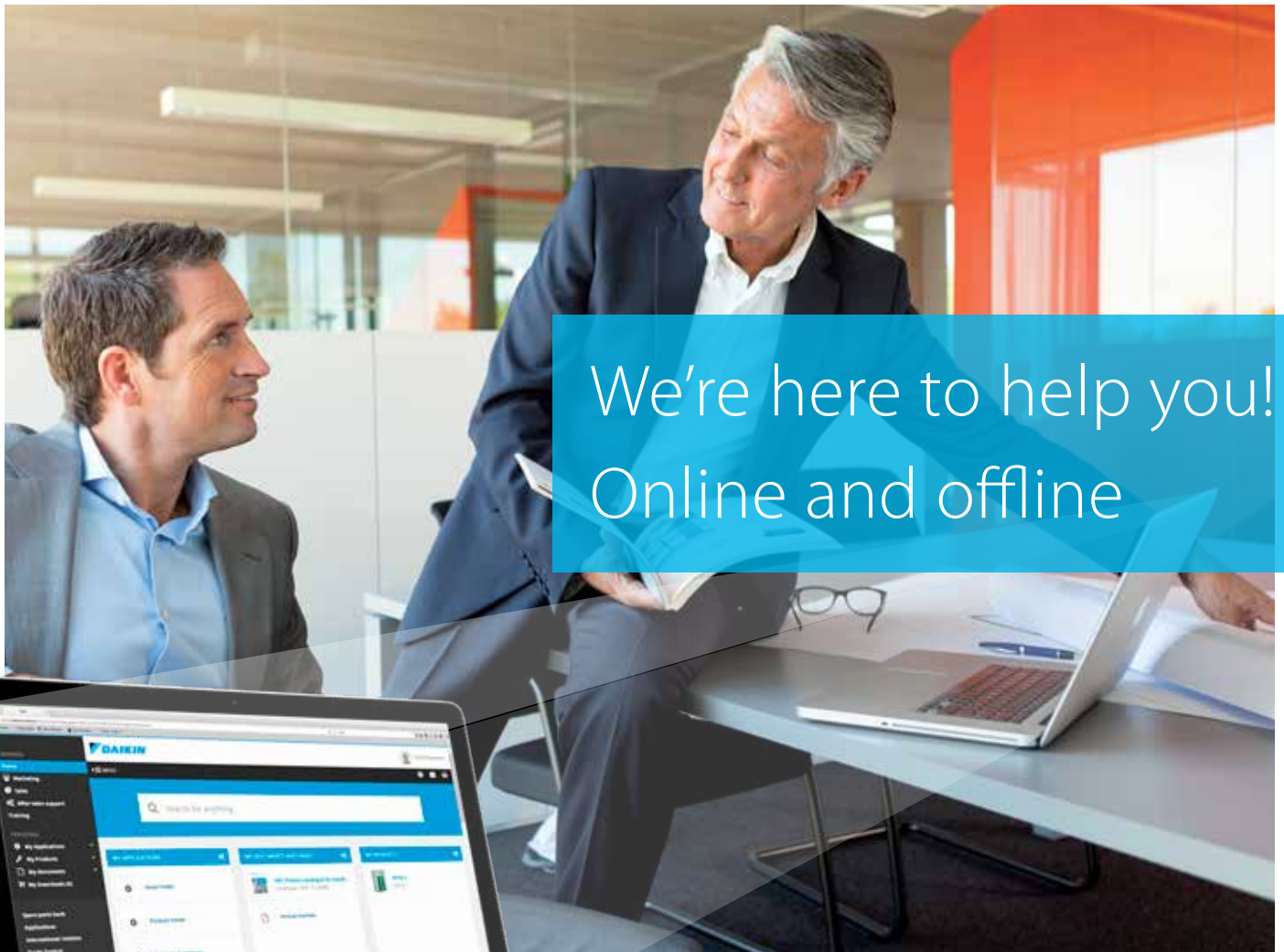

We're here to help you!
Online and offline



<http://literature.daikinpromoshop.eu>

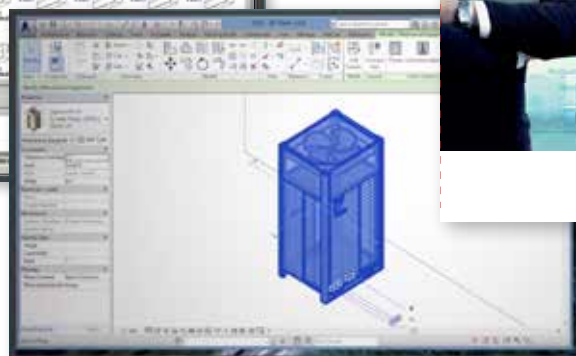
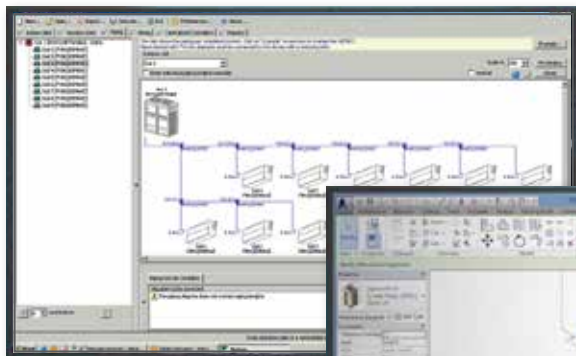

Tools and platforms

Literature overview	164
Supporting tools, software and apps	166

Commercial market - literature overview

for professional network

Solution guides:

Reference books:



Product profiles:



VRV IV range
Detailed VRV IV standards and technologies benefits. Main features and specs of VRV IV product range

206



VRV IV i-series
Main benefits, application examples and specs of VRV IV i-series product range

207



VRV IV S-series
Main benefits, application examples and specs of VRV IV S-series product range

208



Sky Air A-series
Main benefits and specs

116



Water-to-air heat pump
Detailed info on VRV IV W-series, application examples, technical system design background

209

Focus topics:



Replacement Technology
Clear installer benefits of VRV replacement technology

214



Infrastructure cooling
Clear installer benefits why to choose Daikin for infrastructure cooling

140

Product flyers:



Wired Remote Control
Detailed info on BRC1E52A/B remote control

306

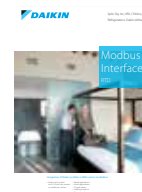

RTD modbus interface
Detailed info on RTD controls and applications

308

Product catalogues:



Sky Air Catalogue
Detailed technical information & benefits on Sky Air/Ventilation/Biddle Air Curtain/Control systems/AHU

100



VRV Catalogue
Detailed technical information & benefits of the VRV total solution

200



Ventilation Catalogue
Detailed info on Ventilation products

203

for your customers



Commercial Solutions
Daikin offers solutions for commercial applications

100



Green Building Solutions
Clear building owner/investor benefits why to choose Daikin for a green building, with emphasis on BREEAM

216

Reference catalogue
Daikin commercial and industrial references

213



Hotel Solutions
Clear building owner/investor benefits why to choose Daikin for a hotel

218



Intelligent Touch Manager
Detailed benefits of Intelligent Touch Manager

302



DCC601A51
Detailed benefits of DCC601A51 and Daikin Cloud Service

303

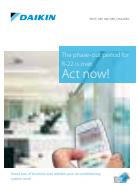

Replacement technology
Clear building owner/investor benefits of replacement technology

215



Sky Air product leaflets
Single page leaflet with the main benefits and technical specifications of each individual Sky Air unit. Ideal for quotations



VRV product leaflets
Single page leaflet with the main benefits and technical specifications of each individual VRV unit. Ideal for quotations



Technical documentation:

All latest Daikin catalogues are available in a convenient library on the internet:
www.daikineurope.com/support-and-manuals/catalogues



Supporting tools, software and apps

[www.daikineurope.com/
support-and-manuals/
software-downloads](http://www.daikineurope.com/support-and-manuals/software-downloads)

Software

Ventilation Xpress

Selection tool for ventilation devices (VAM, VKM). The selection is based on given supply/extract airflows (including fresh up and given ESP of supply/extract ducting):

- › Determines size of electrical heaters
- › Visualisation of psychrometric chart
- › Visualisation of selected configuration
- › Required field settings mentioned in the report

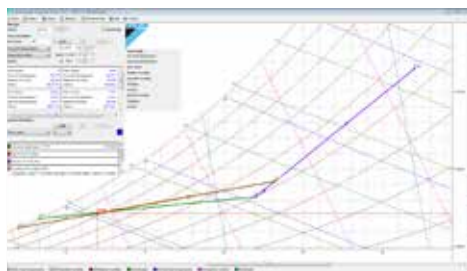

Webbased ASTRA selection **NEW** for air handling units

A powerful tool to select the right Air Handling Units for your needs.

- › 3D interface
- › quick selection procedures
- › new print-out possibilities and report shapes



WAGO selection tool **NEW**

The WAGO Selection Tool is specifically designed to select the optimal WAGO I/O system for your needs.

- › Easy selection of WAGO materials
- › Material list creation
- › Time saving
 - Includes wiring schemes
 - Contains commissioning/preset data for



Plugins and third-party software tools

Building Information Modelling (BIM) support

- › BIM improves efficiency of design and build phase
- › Daikin is among the first to supply a full library of BIM objects for its VRV products



[http://bimobject.com/en/
product/
?freetext=daikin](http://bimobject.com/en/product/?freetext=daikin)

Energy simulation and design aid tools

Psychrometrics diagram **NEW**

- › The Psychrometrics Diagram Viewer demonstrates the changing properties of moist air.
- › With this tool, users can choose two points with specific conditions, plot them on the diagram and select actions to change the conditions, i.e. heat, cool and mix air.

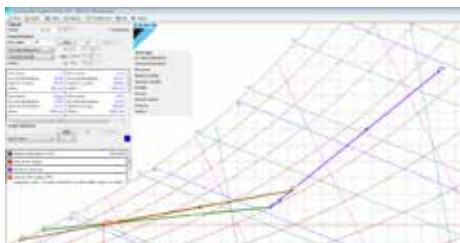

Service tools

Error code app

Quickly know the meaning of fault codes, for each product family and the potential cause



D-Checker

D-checker is a software application used to record and monitor operation data of Daikin applied, split, Multi-split, Sky-air units, Daikin Altherma LT, ground source heat pump, Hybrid, ZEAS, Conveni-pack & R410A Booster unit

Bluetooth adaptor **NEW**

Monitoring of Split, Sky Air and VRV data via any bluetooth device

- › No need to access the outdoor unit
 - Connects with D-Checker software (for laptops)
 - Connects with monitoring app (for tablets or smartphones)



Diagnosis of the Bluetooth system possible:

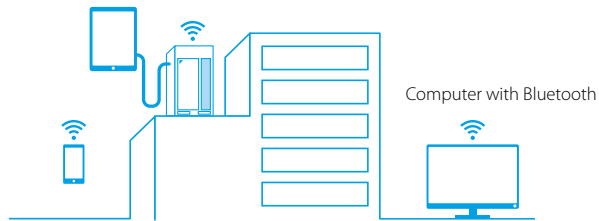

Online support

NEW Business portal

- › Experience our new extranet that thinks with you at my.daikin.eu
- › Find information in seconds via a powerful search
- › Customise the options so you see only info relevant for you
- › Access via mobile device or desktop

my.daikin.eu



Internet

Find our solution for different applications:

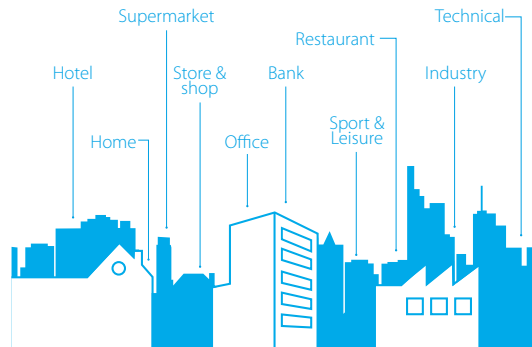

- › Get more commercial details on our flagship products via our dedicated minisites
- › See our references



www.daikineurope.com/references

Europe's new energy label

Labelling to encourage intelligent choices

To enable consumers to compare and make purchasing decisions based on uniform labelling criteria, Europe has introduced energy labels. The previous European energy label for air conditioners, introduced in 1992, did its job for the time. In 2013, Europe introduced a seasonal energy label. This label allows end users to make even more informed choices, since seasonal efficiency reflects air conditioner efficiency over an entire season.

The energy label includes multiple classifications from A+++ to D, reflected in colour shadings ranging from dark green (most energy efficient) to red (least efficient). Information on the label not only includes the seasonal efficiency ratings for heating (SCOP) and cooling (SEER), but also annual energy consumption and noise levels.

The label more in detail

Name of manufacturer and product

SEER: seasonal efficiency values for cooling

Classifications from A+++ (most energy efficient) to D (least energy efficient)

Design load for cooling

Seasonal efficiency ratings for cooling (SEER)

Annual energy consumption during a cooling season, including auxiliary modes

Sound power value for indoor unit

Sound power value for outdoor unit

Combination of indoor and outdoor unit

SCOP: seasonal efficiency values for heating

Classifications from A+++ (most energy efficient) to D (least energy efficient)

Design load for heating

Seasonal efficiency ratings for heating (SCOP)

Annual energy consumption during a heating season, including auxiliary modes

To take the broad range of conditions into account, 3 climate zones are used: cold, average and warm

BLUE = COLDER CLIMATE (OPTIONAL)
 GREEN = AVERAGE CLIMATE (COMPULSORY)
 ORANGE = WARMER CLIMATE (OPTIONAL)

Measuring conditions

Power supply

T1	=	3~, 220V, 50Hz
V1	=	1~, 220-240V, 50Hz
VE	=	1~, 220-240V/220V, 50Hz/60Hz*
V3	=	1~, 230V, 50Hz
VM	=	1~, 220~240V/220~230V, 50Hz/60Hz
W1	=	3N~, 400V, 50Hz
Y1	=	3~, 400V, 50Hz

* For VE power supply only 1~, 220-240V, 50Hz data is displayed in this catalogue.

Conversion table refrigerant piping

inch	mm
1/4"	6.4 mm
3/8"	9.5 mm
1/2"	12.7 mm
5/8"	15.9 mm
3/4"	19.1 mm
7/8"	22.2 mm
1 1/8"	28.5 mm
1 3/8"	34.9 mm
1 5/8"	41.3 mm
1 3/4"	44.5 mm
2"	50.8 mm
2 1/8"	54 mm
2 5/8"	66.7 mm

F-gas regulation

For fully/partially charged equipment: contains fluorinated greenhouse gases. Actual refrigerant charge depends on the final unit construction, details can be found on the unit labels.

For non pre-charged equipment (Chillers: split chiller (SEHVX/SERHQ), condensing units and condenserless chillers + refrigeration (LCBKQ-AV1, JEHCUCU/JEHCUCU and ICU): Its functioning relies on fluorinated greenhouse gases.

Measuring conditions

Air conditioning

1) Nominal cooling capacities are based on:	
Indoor temperature	27°CDB/19°CWB
Outdoor temperature	35°CDB
Refrigerant piping length	7.5m - 8/5m VRV
Level difference	0m
2) Nominal heating capacities are based on:	
Indoor temperature	20°CDB
Outdoor temperature	7°CDB/6°CWB
Refrigerant piping length	7.5m - 8/5m VRV
Level difference	0m

The sound pressure level is measured via a microphone at a certain distance from the unit. It is a relative value, depending on the distance and acoustic environment (for measuring conditions: please refer to the technical databooks). The sound power level is an absolute value indicating the "power" which a sound source generates. For more detailed information please consult our technical databooks.



Technical drawings

Indoor units	172
Outdoor units	202
Biddle air curtains	255



Technical drawings

Indoor units

FCAG-A / FCAHG-G	173
FFA-A	175
FDXM-F3	177
FBA-A	180
FDA-A	185
FDQ-B	188
ABQ-C	190
FAA-A	192
FHA-A	193
AHQ-C	196
FUA-A	197
FVA-A	198
FNA-A	199



FCAG-A / FCAHG-G WITH AUTO-CLEANING PANEL

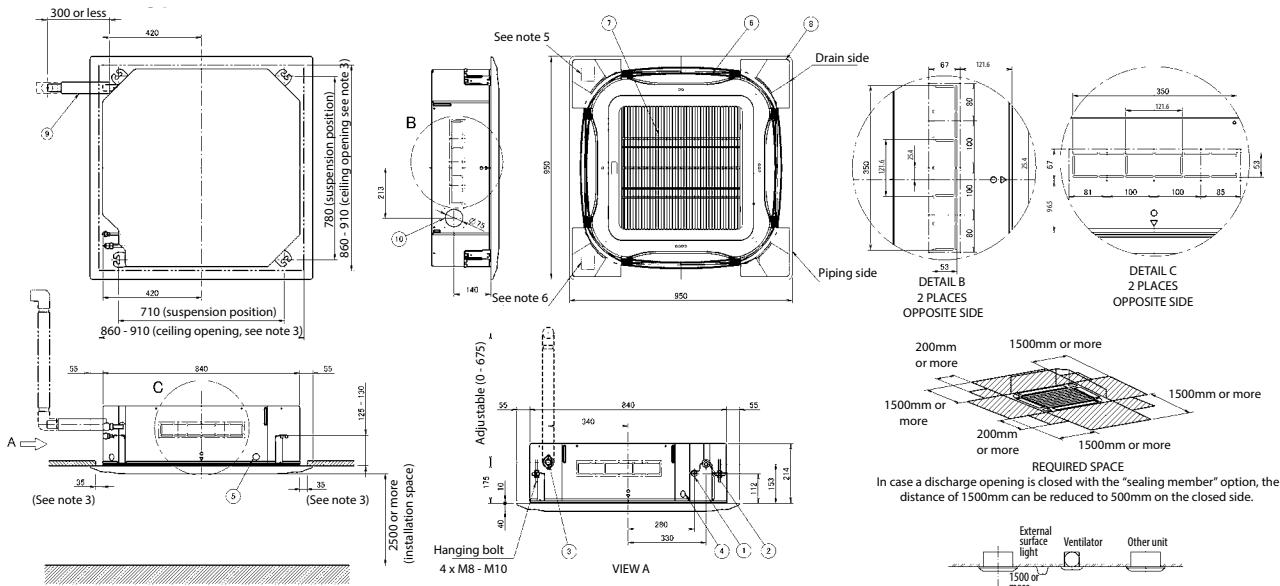

NOTE

1. Location of the nameplates
- Unit body: on the control box cover
- Decoration panel: on the panel frame at the piping side under the corner cover
2. When installing an optional accessory, refer to the installation drawings.
- For fresh air intake kit an inspection part is necessary
3. Make sure the spacing between the ceiling and the cassette is no more than 35mm. Max ceiling opening: 910mm
4. When the conditions exceed 30°C and RH 80% in the ceiling or fresh air is inducted into the ceiling, an additional insulation is required (polyethylene foam, thickness 10mm or more)
5. In case of using a sensor kit, this position will be a sensor, refer to the drawing of the sensor kit for more detail
6. In case of using an infrared control, this position will be a receiver, refer to the drawing of the infrared control for more detail

Item	Name
1	Liquid pipe connection
2	Gas pipe connection
3	Drain pipe connection
4	Power supply entry hole
5	Transmission wiring entry hole
6	Air discharge opening
7	Air suction grille
8	Corner decoration cover
9	Drain hose
10	Knock out hole

Model	
FCQG35-71FVEB, FXFQ20-63AVEB	2D090245A

FCAG-A / FCAHG-G WITH STANDARD PANEL

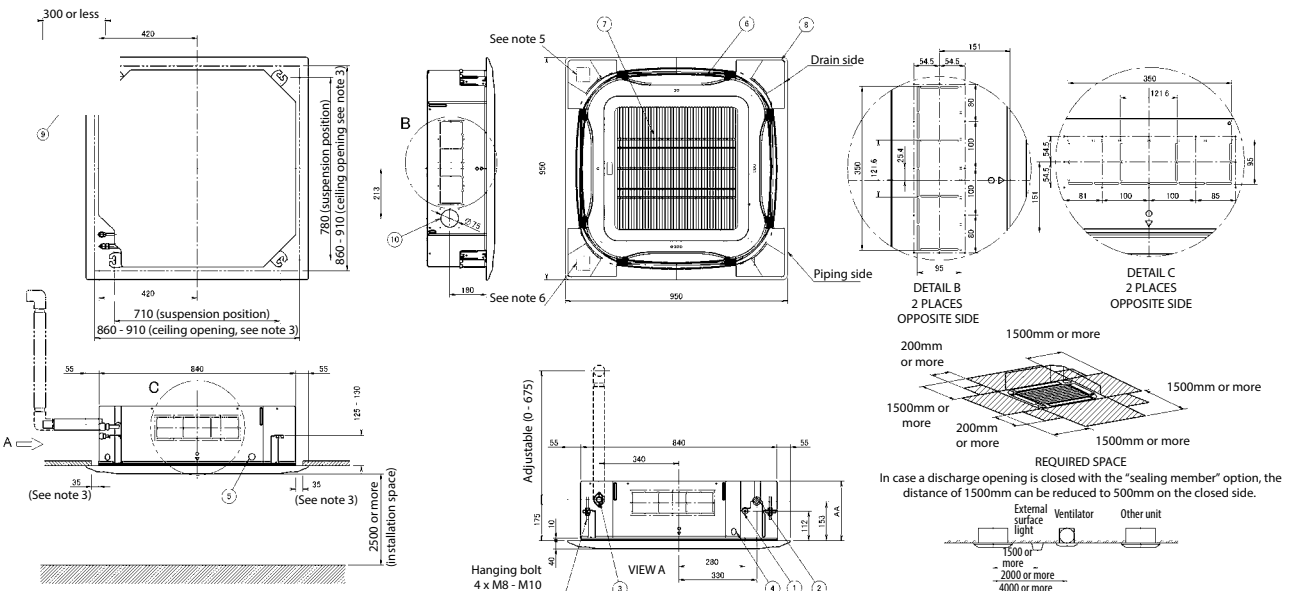

NOTE

1. Location of the nameplates
- Unit body: on the control box cover
- Decoration panel: on the panel frame at the piping side under the corner cover
2. When installing an optional accessory, refer to the installation drawings.
- For fresh air intake kit an inspection part is necessary
3. Make sure the spacing between the ceiling and the cassette is no more than 35mm. Max ceiling opening: 910mm
4. When the conditions exceed 30°C and RH 80% in the ceiling or fresh air is inducted into the ceiling, an additional insulation is required (polyethylene foam, thickness 10mm or more)
5. In case of using a sensor kit, this position will be a sensor, refer to the drawing of the sensor kit for more detail
6. In case of using an infrared control, this position will be a receiver, refer to the drawing of the infrared control for more detail

Item	Name
1	Liquid pipe connection
2	Gas pipe connection
3	Drain pipe connection
4	Power supply entry hole
5	Transmission wiring entry hole
6	Air discharge opening
7	Air suction grille
8	Corner decoration cover
9	Drain hose
10	Knock out hole

Model	
256 FCQG100-140FVEB, FXFQ80-100AVEB	
298 FCQH71-140FVEB, FXFQ125AVEB	

3D077130E

Detailed technical drawings

FCAG-A

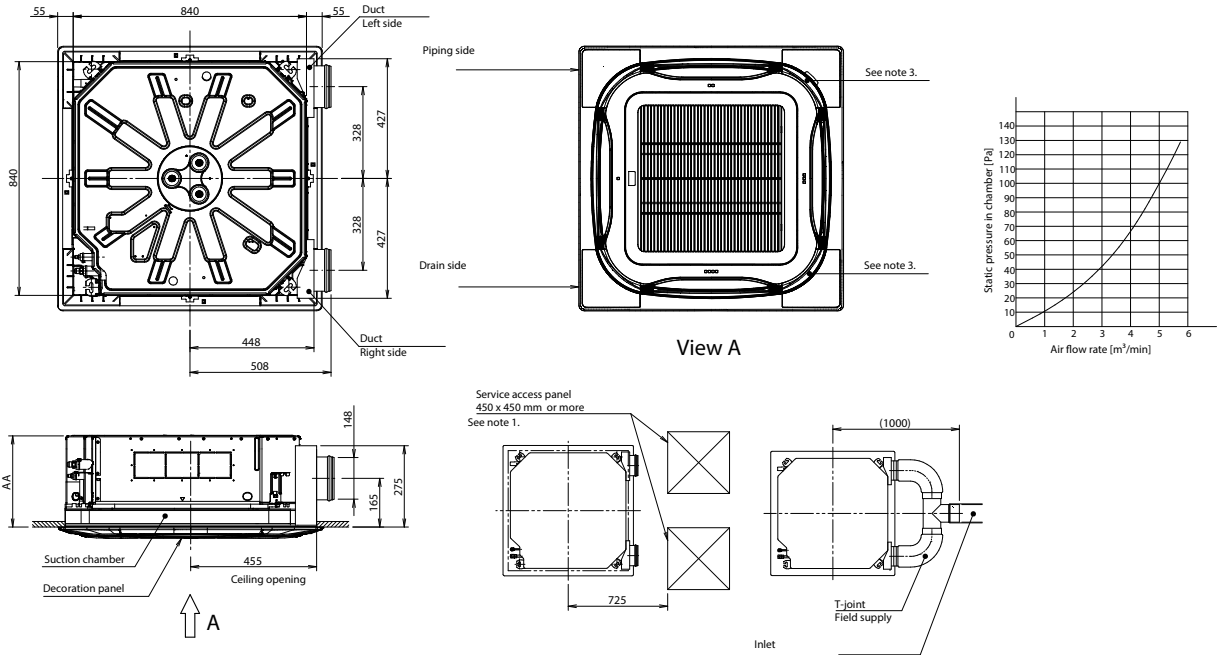

Notes

1. When installing a fresh air intake kit, provide a service access panel.
2. Field construction
3. This corner discharge outlet needs to be closed.
4. When installing a duct fan, use a wiring adapter to link the duct fan to the fan of the indoor unit.
5. The intake air flow rate is recommended to be $\leq 20\%$ of the air flow rate at high fan speed.
If the intake air flow rate is too large, the operating sound may increase, and the detection of the indoor unit suction temperature may be affected.
6. This indicates the distance between the T-joint inlet and the indoor unit inlet when the T-tube is connected.

3D106327

FCAG-A

Sensor kit Installation methods

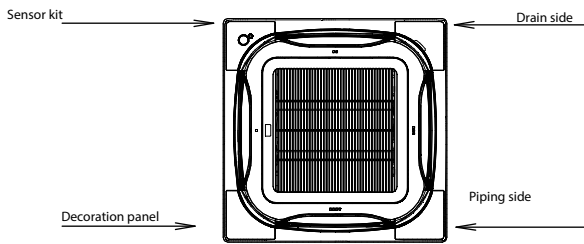

Sensor kit	BRYQ140A7
Decoration panel	BYCQ140D7W1 (W)

Sensor kit Installation methods

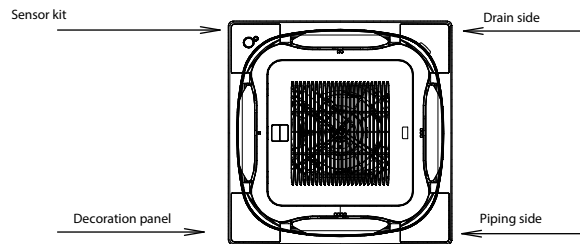

Sensor kit	BRYQ140A7
Decoration panel	BYCQ140D7GW9/BYCQ140D7GFW9

4D106294



FFA25-35A - FULLY FLAT PANEL

• DECORATION PANEL

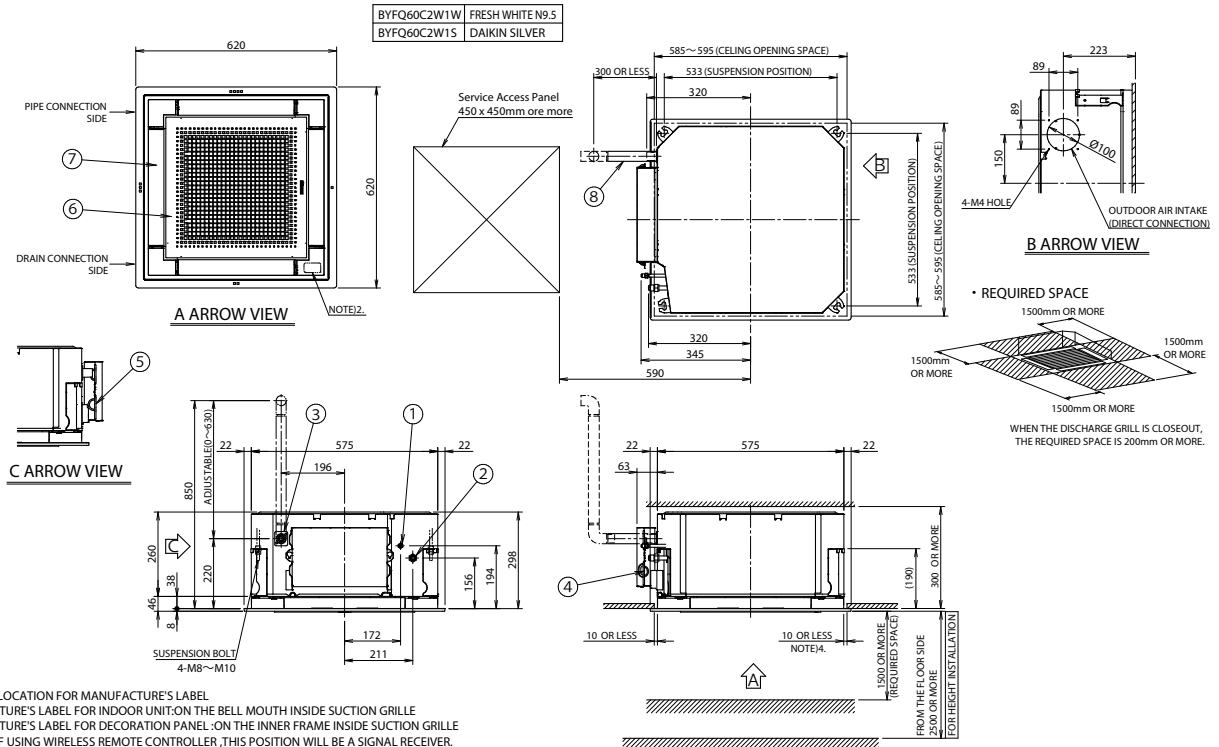

- NOTE 1. STICKING LOCATION FOR MANUFACTURE'S LABEL
MANUFACTURE'S LABEL FOR INDOOR UNIT: ON THE BELL MOUTH INSIDE SUCTION GRILLE
MANUFACTURE'S LABEL FOR DECORATION PANEL: ON THE INNER FRAME INSIDE SUCTION GRILLE
2. IN CASE OF USING WIRELESS REMOTE CONTROLLER, THIS POSITION WILL BE A SIGNAL RECEIVER. REFER TO THE DRAWING OF WIRELESS REMOTE CONTROLLER IN DETAIL.
3. WHEN THE TEMPERATURE AND HUMIDITY IN THE CEILING EXCEED 30 °C AND RH 80% OR THE FRESH AIR IS INDUCTED INTO THE CEILING OR THE UNIT CONTINUES 24 HOUR OPERATION, AN ADDITIONAL INSULATION (THICKNESS 10mm OR MORE OF GLASSWOOL OR POLYETHYLENE FOAM) IS REQUIRED.
4. THOUGH THE INSTALLATION IS ACCEPTABLE UP TO MAXIMUM OF 595mm SQUARE CEILING OPENING, KEEP THE CLEARANCE OF 10mm OR LESS BETWEEN THE MAIN UNIT AND THE CEILING OPENING SO THAT THE PANEL OVERLAP ALLOWANCE CAN BE ENSURED.

ITEM	PART NAME	REMARK	ITEM	PART NAME	REMARK
1	LIQUID PIPE CONNECTION	φ6.4(FRAME CONNECTION)	5	REMOTE CONTROL CODE AND CONTROL WIRING CONNECTION	
2	GAS PIPE CONNECTION	φ9.5(FRAME CONNECTION)	6	AIR DISCHARGE GRILLE	
3	DRAIN PIPE CONNECTION	VP20(O.D.φ26)	7	SUCTION GRILLE	
4	POWER SUPPLY CONNECTION		8	DRAIN HOSE (ACCESSORY)	LDφ25(OUTLET)

3D082433

FFA25-35A - STANDARD PANEL

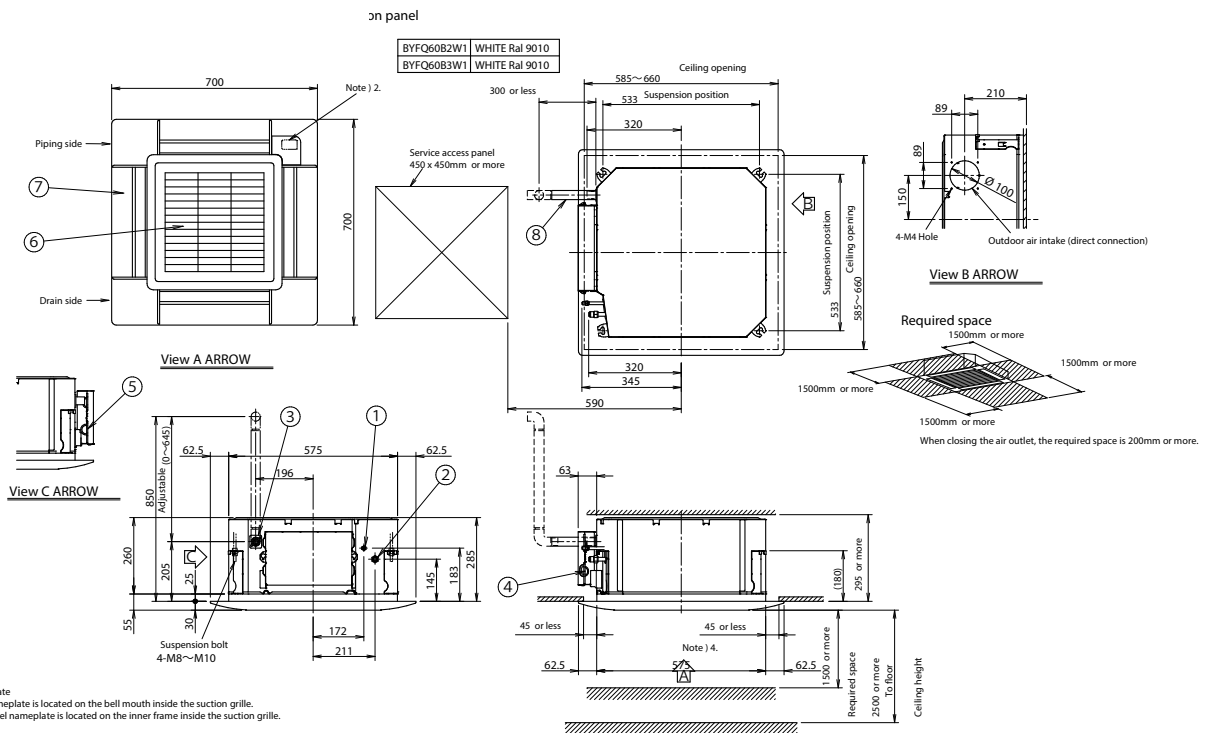

- Note)
1. Location of nameplate
The indoor unit nameplate is located on the bell mouth inside the suction grille.
The decoration panel nameplate is located on the inner frame inside the suction grille.
2. When installing a wireless controller, there will be a receiver on this location. For details, see the drawing of the wireless controller.
3. If any of the following conditions are met, additional insulation (glass wool or polyethylene foam, thickness ≥10mm) is required:
Ambient conditions in the ceiling > 30°C and 80% relative humidity.
Fresh air is inducted into the ceiling.
The unit operates continuously.
4. Though the installation is acceptable up to maximum 660mm square ceiling opening, keep the clearance of 45mm or less between the indoor unit and the ceiling opening, so that the panel overlap allowance can be ensured.

Item	Part name	Remark	Item	Part name	Remark
1	Liquid pipe connection	φ6.4	5	Remote control wiring intake	
2	Gas pipe connection	φ9.5	6	Air discharge grille	
3	Drain pipe connection	VP20(O.D.φ26)	7	Air suction grille	
4	Power supply		8	Drain hose Accessory	LDφ25 Outlet

3D082434C



FFA50-60A - FULLY FLAT PANEL

• DECORATION PANEL

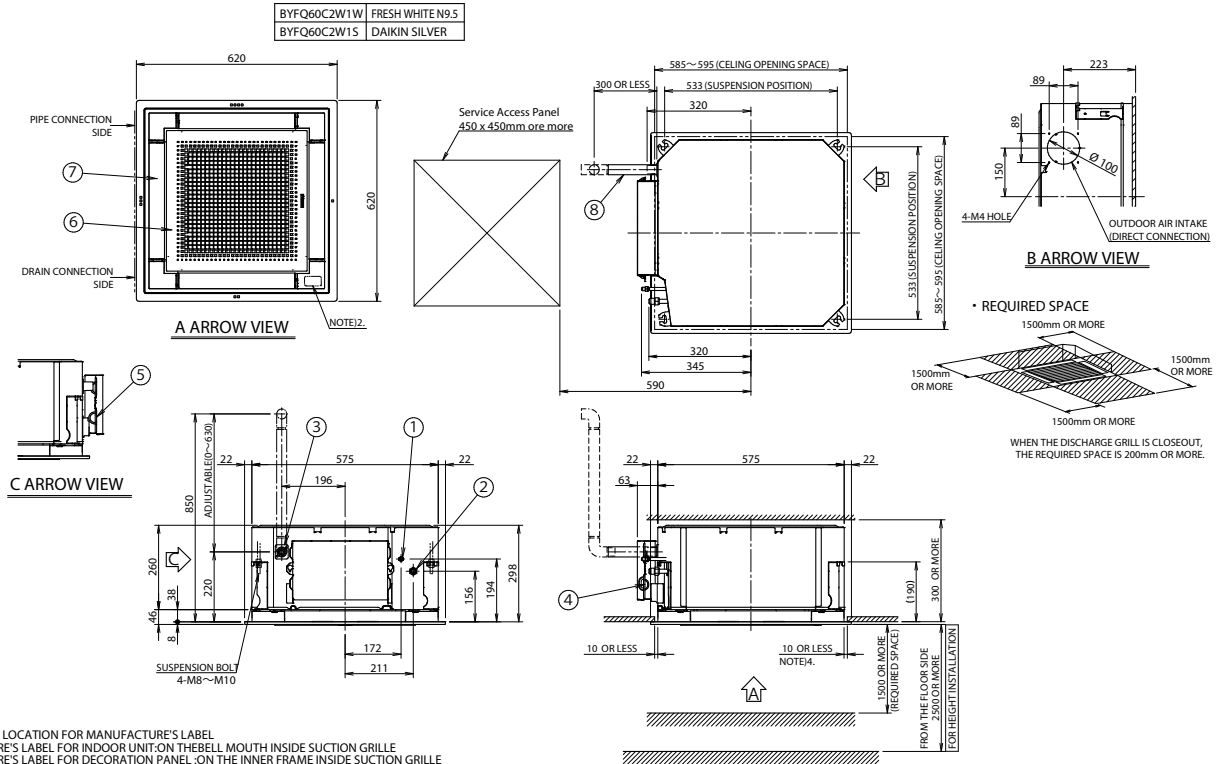

NOTE 1. STICKING LOCATION FOR MANUFACTURE'S LABEL
 MANUFACTURE'S LABEL FOR INDOOR UNIT ON THE BELL MOUTH INSIDE SUCTION GRILLE
 MANUFACTURE'S LABEL FOR DECORATION PANEL ON THE INNER FRAME INSIDE SUCTION GRILLE
 2. IN CASE OF USING WIRELESS REMOTE CONTROLLER, THIS POSITION WILL BE A SIGNAL RECEIVER. REFER TO THE DRAWING OF WIRELESS REMOTE CONTROLLER IN DETAIL.
 3. WHEN THE TEMPERATURE AND HUMIDITY IN THE CEILING EXCEED 30 °C AND RH 80% OR THE FRESH AIR IS INDUCTED INTO THE CEILING OR THE UNIT CONTINUES 24 HOUR OPERATION, AN ADDITIONAL INSULATION (THICKNESS 10mm OR MORE OF GLASSWOL OR POLYETHYLENE FORM) IS REQUIRED.
 4. THOUGH THE INSTALLATION IS ACCEPTABLE UP TO MAXIMUM OF 595mm SQUARE CEILING OPENING, KEEP THE CLEARANCE OF 10mm OR LESS BETWEEN THE MAIN UNIT AND THE CEILING OPENING SO THAT THE PANEL OVERLAP ALLOWANCE CAN BE ENSURED.

ITEM	PART NAME	REMARK	ITEM	PART NAME	REMARK
1	LIQUID PIPE CONNECTION	φ6.4(FRARE CONNECTION)	5	REMOTE CONTROL CODE AND CONTROL WIRING CONNECTION	
4	GAS PIPE CONNECTION	φ12.7(FRARE CONNECTION)	6	AIR DISCHARGE GRILLE	
3	DRAIN PIPE CONNECTION	VP20(O.D.φ26)	7	SUCTION GRILLE	
4	POWER SUPPLY CONNECTION		8	DRAIN HOSE (ACCESSORY)	1.D.φ25 (OUTLET)

3D082052

FFA50-60A - STANDARD PANEL

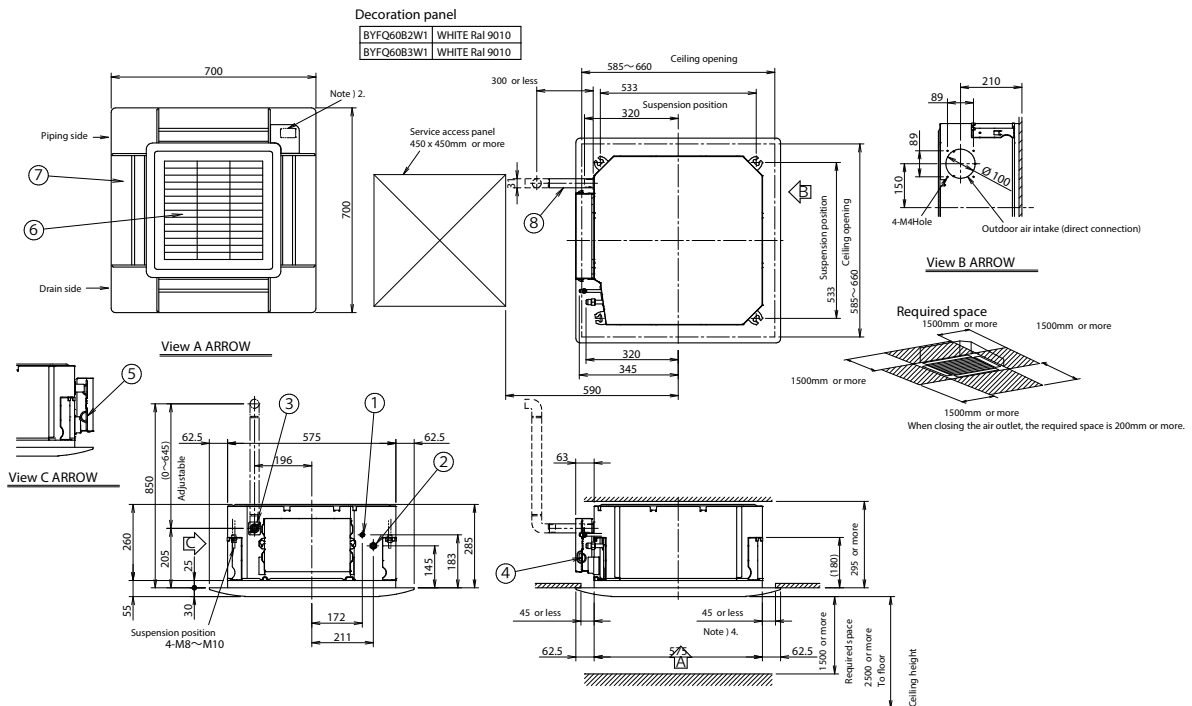

Note)
 1. Location of nameplate
 The indoor unit nameplate is located on the bell mouth inside the suction grille.
 The decoration panel nameplate is located on the inner frame inside the suction grille.
 2. When installing a wireless controller, there will be a receiver on this location. For details, see the drawing of the wireless controller.
 3. If any of the following conditions are met, additional insulation (glass wool or polyethylene foam, thickness ≥ 10mm) is required:
 Ambient conditions in the ceiling ≥ 30°C and 80% relative humidity.
 Fresh air is inducted into the ceiling. The unit operates continuously.
 4. Though the installation is acceptable up to maximum 660mm square ceiling opening, keep the clearance of 45mm or less between the indoor unit and the ceiling opening, so that the panel overlap allowance can be ensured.

Item	Part name	Remark	Item	Part name	Remark
1	Liquid pipe connection	φ6.4 Flare connection	5		
2	Gas pipe connection	φ12.7 Flare connection	6	Air discharge grille	
3	Drain pipe connection	VP20(O.D. φ 26)	7	Air suction grille	
4	Power supply		8	Drain hose Accessory	1.D.φ25 Outlet

3D082161C



FDXM25-35F3

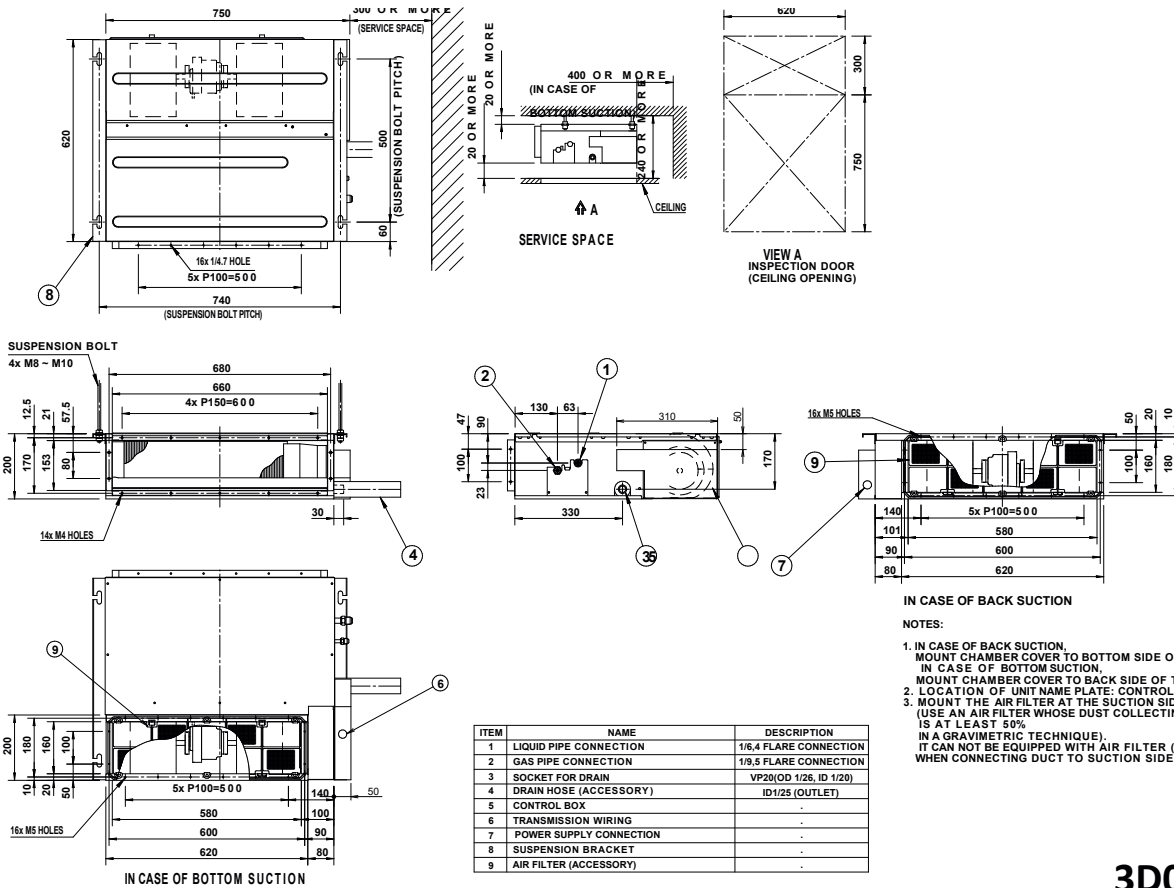

3D081343

FDXM50-60F3

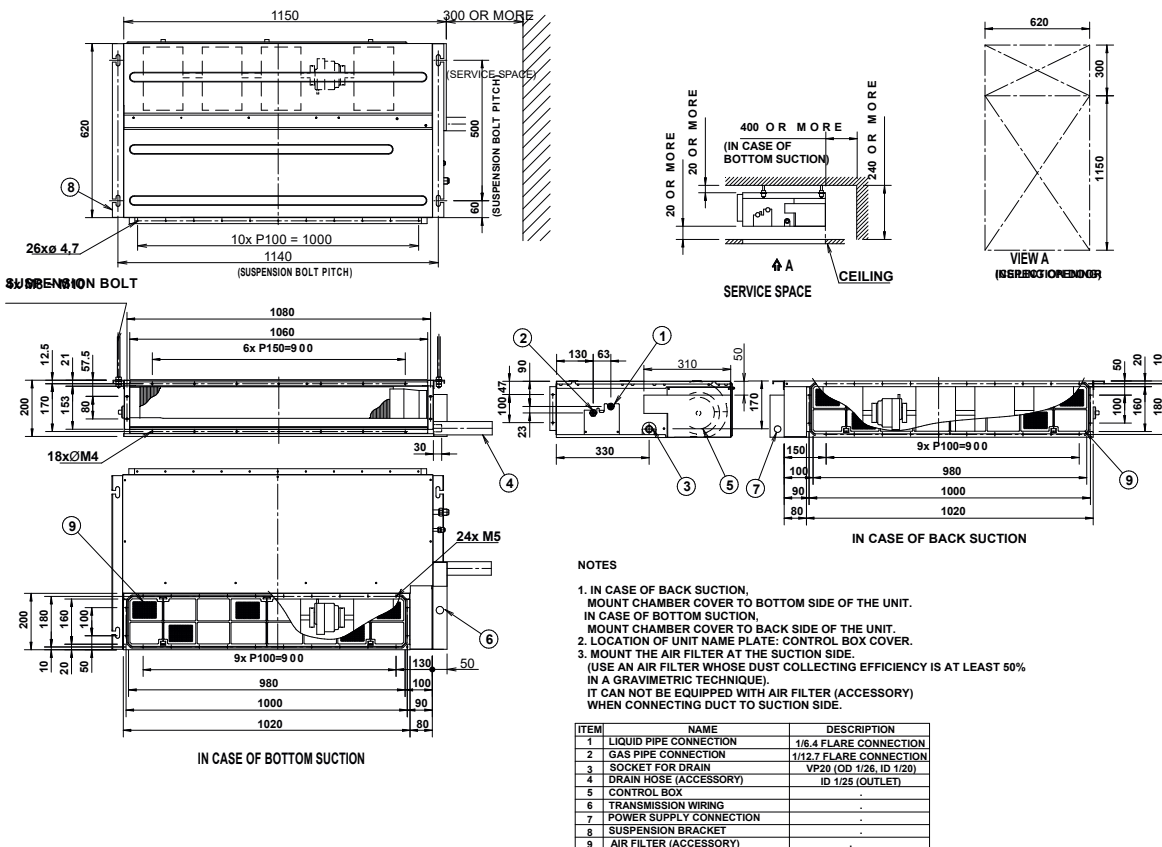

3D081360

FDXM25-35F3

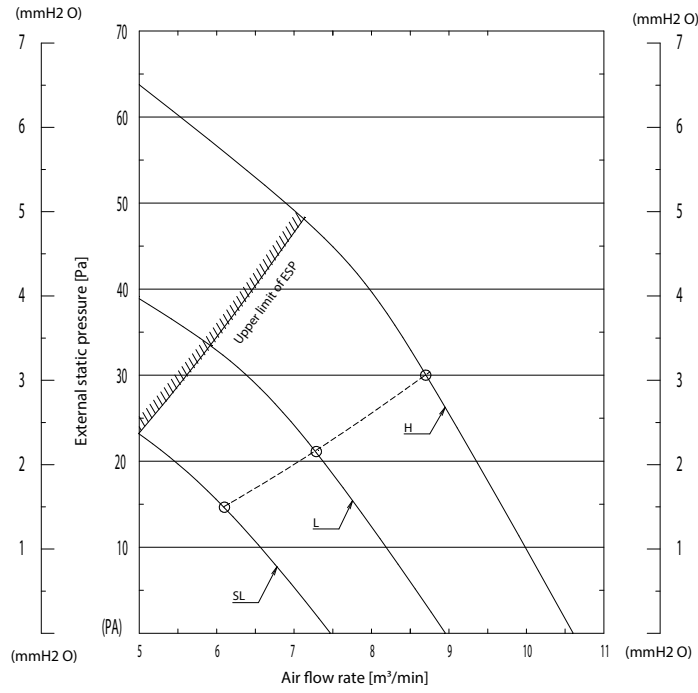

3D081327C

FDXM50F3

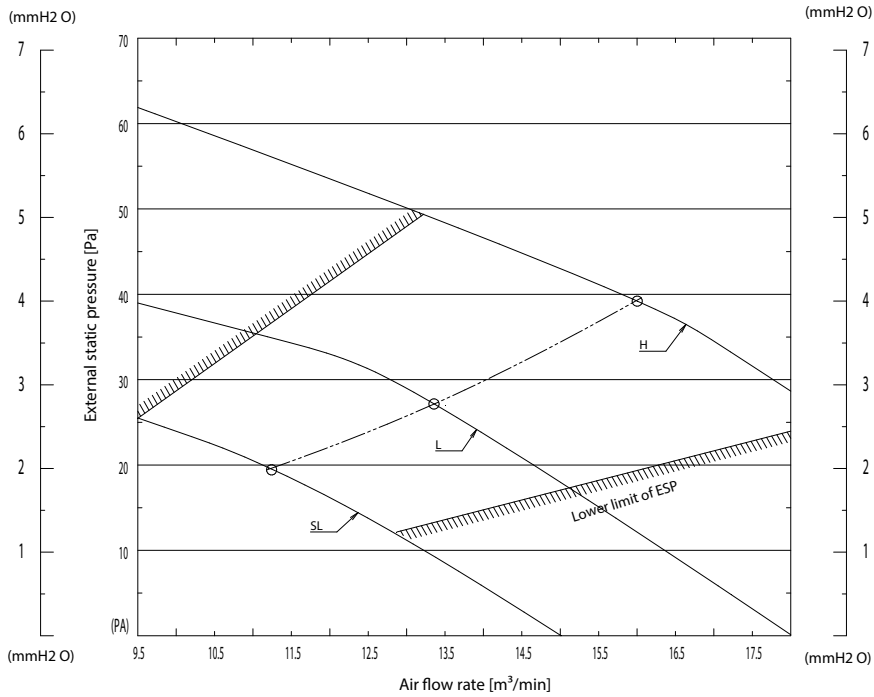

3D085960C



FDXM60F3

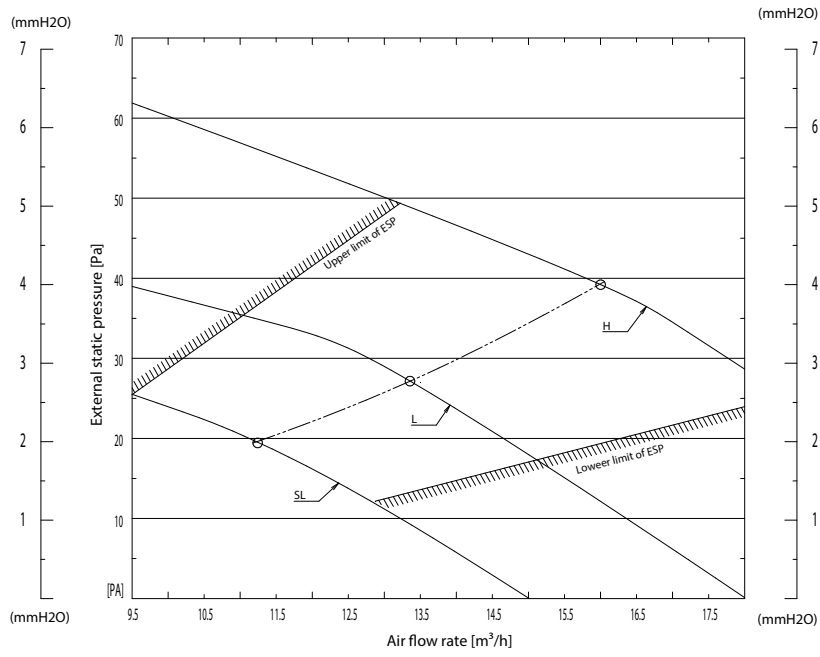

3D081329



Detailed technical drawings

FBA35A

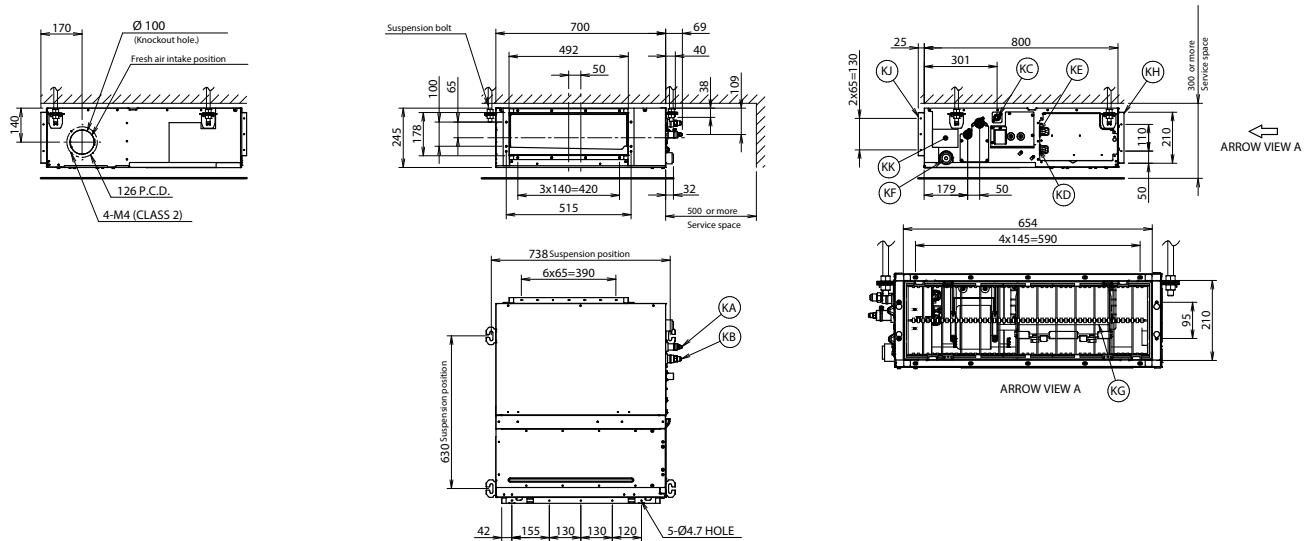

Item	Name	Description
KA	Liquid pipe connection port	Ø6.35 flared connection
KB	Gas pipe connection port	Ø9.52 flared connection
KC	Drain pipe connection	VP20 (OD Ø26, ID Ø20)
KD	Wiring connection	/
KE	Power supply connection	/
KF	Drain outlet	VP20 (OD Ø26, ID Ø20)
KG	Air filter	/
KH	Air suction side	/
KJ	Air discharge side	/
KK	Nameplate	/

Notes
 1. When installing optional accessories, refer to their respective documentation.
 2. The ceiling depth varies according to the documentation of the specific system.

3D094988B

FBA50A

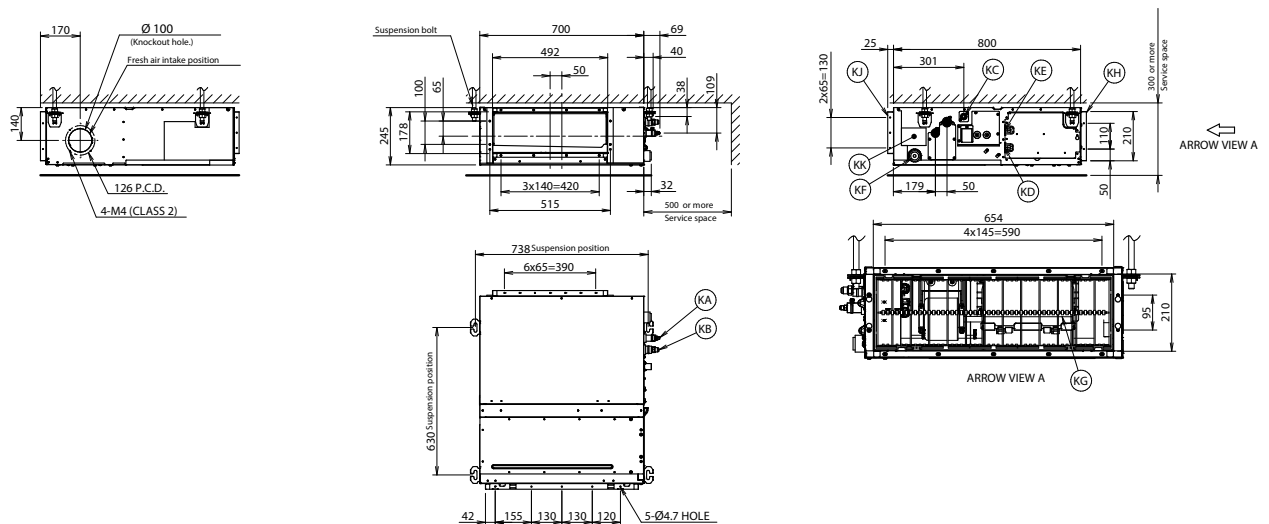

Item	Name	Description
KA	Liquid pipe connection port	Ø6.35 flared connection
KB	Gas pipe connection port	Ø12.70 flared connection
KC	Drain pipe connection	VP20 (OD Ø26, ID Ø20)
KD	Wiring connection	/
KE	Power supply connection	/
KF	Drain outlet	VP20 (OD Ø26, ID Ø20)
KG	Air filter	/
KH	Air suction side	/
KJ	Air discharge side	/
KK	Nameplate	/

Notes
 1. When installing optional accessories, refer to their respective documentation.
 2. The ceiling depth varies according to the documentation of the specific system.

3D094918B



FBA60A

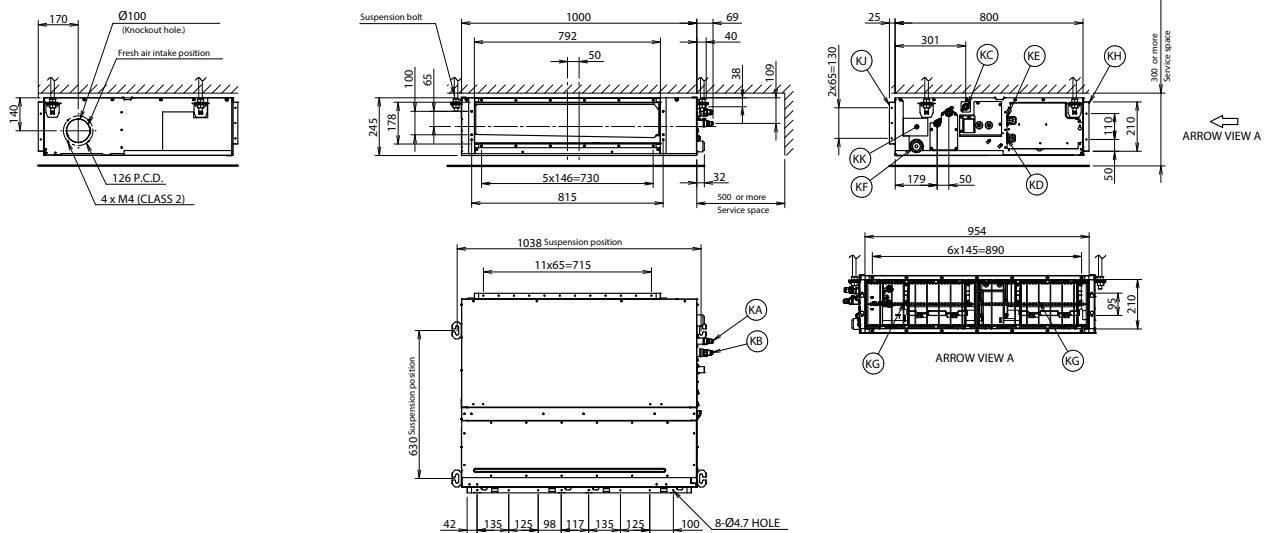

Item	Name	Description
KA	Liquid pipe connection port	Ø6.35 flared connection
KB	Gas pipe connection port	Ø12.70 flared connection
KC	Drain pipe connection	VP20 (OD Ø26, ID Ø20)
KD	Wiring connection	/
KE	Power supply connection	/
KF	Drain outlet	VP20 (OD Ø26, ID Ø20)
KG	Air filter	/
KH	Air suction side	/
KJ	Air discharge side	/
KK	Nameplate	/

Notes
 1. When installing optional accessories, refer to their respective documentation.
 2. The ceiling depth varies according to the documentation of the specific system.

3D094983B

FBA71A

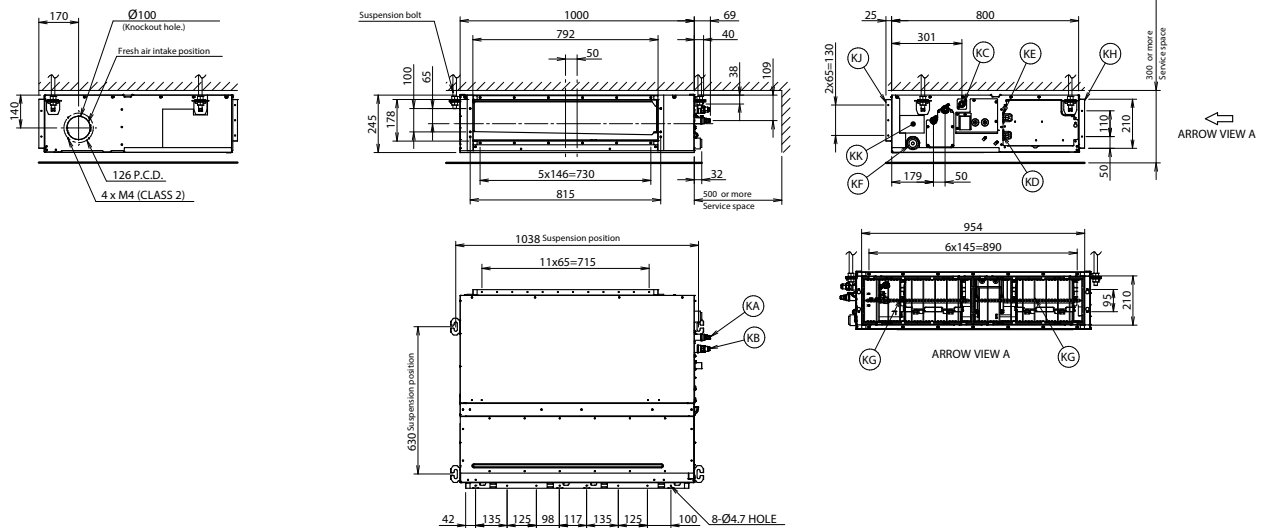

Item	Name	Description
KA	Liquid pipe connection port	Ø9.52 flared connection
KB	Gas pipe connection port	Ø15.90 flared connection
KC	Drain pipe connection	VP20 (OD Ø26, ID Ø20)
KD	Wiring connection	/
KE	Power supply connection	/
KF	Drain outlet	VP20 (OD Ø26, ID Ø20)
KG	Air filter	/
KH	Air suction side	/
KJ	Air discharge side	/
KK	Nameplate	/

Notes
 1. When installing optional accessories, refer to their respective documentation.
 2. The ceiling depth varies according to the documentation of the specific system.

3D094915B



Detailed technical drawings

FBA100-140A

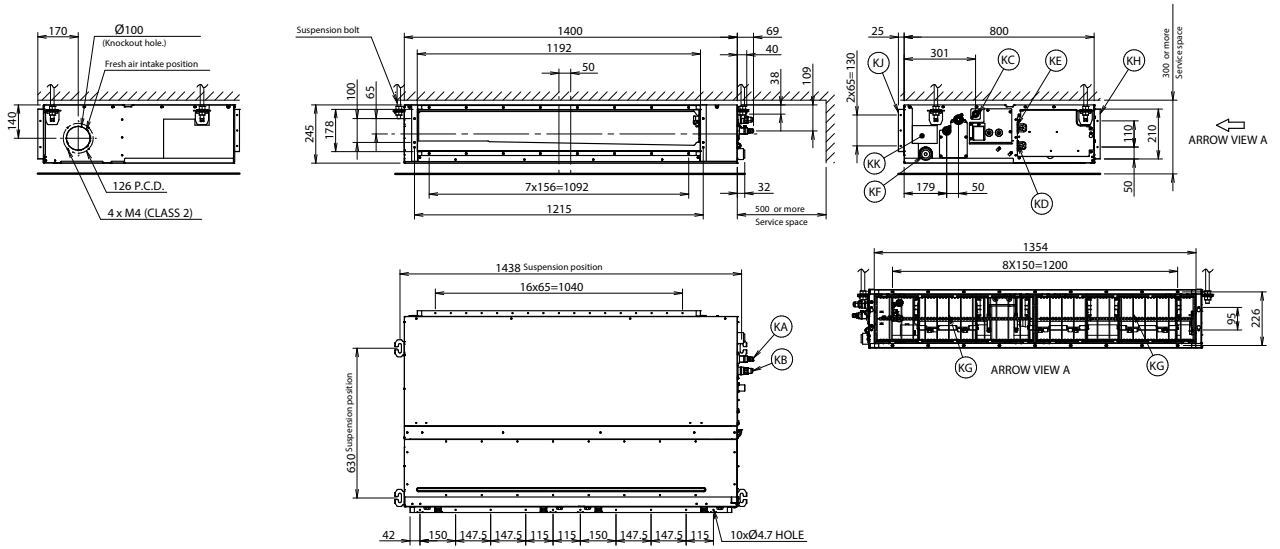

Item	Name	Description
KA	Liquid pipe connection port	Ø9.52 flared connection
KB	Gas pipe connection port	Ø15.90 flared connection
KC	Drain pipe connection	VP20 (OD Ø26, ID Ø20)
KD	Wiring connection	/
KE	Power supply connection	/
KF	Drain outlet	VP20 (OD Ø26, ID Ø20)
KG	Air filter	/
KH	Air suction side	/
KJ	Air discharge side	/
KK	Nameplate	/

Notes
 1. When installing optional accessories, refer to their respective documentation.
 2. The ceiling depth varies according to the documentation of the specific system.

3D094914B

FBA35-50A

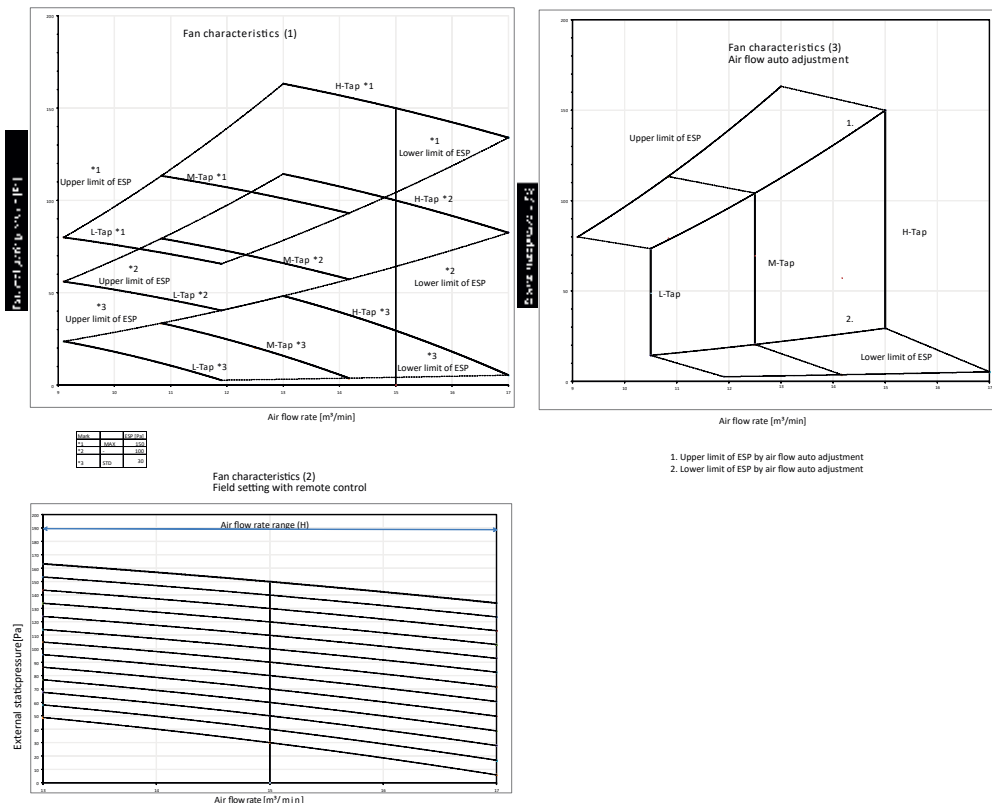

Notes:
 1. The fan characteristics shown are in "fan only" mode.
 2. ESP: External static pressure.

3D095521B



FBA60-71A

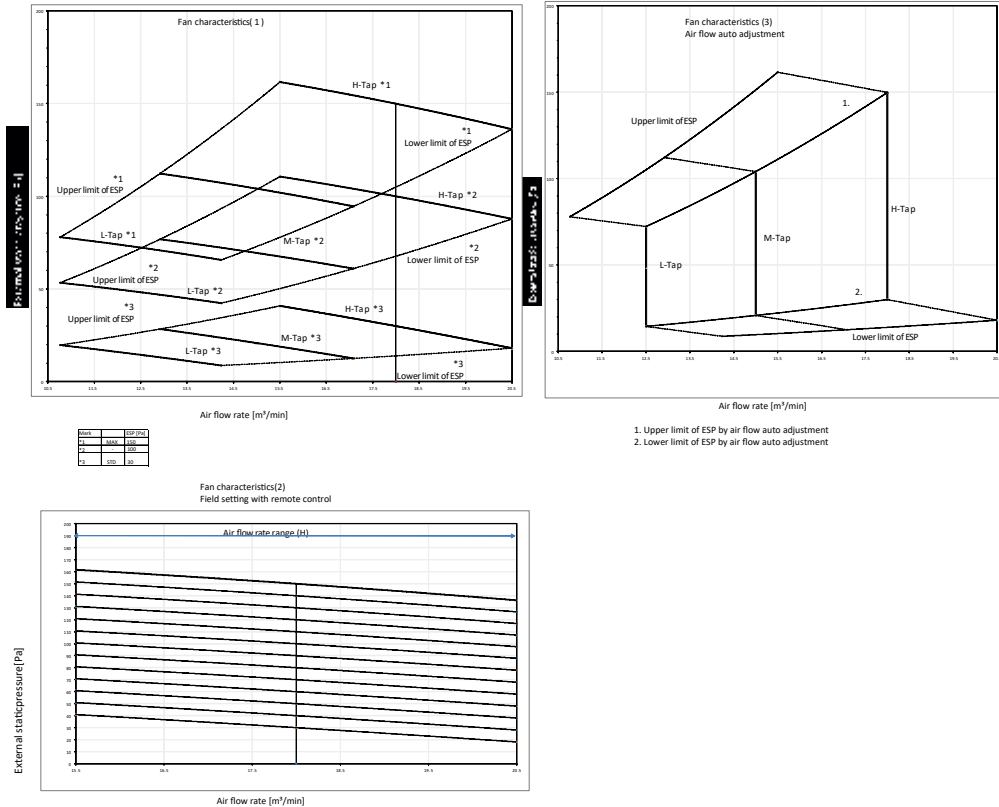

Notes:
 1. Fan characteristics as shown are in "fan only" mode.
 2. ESP: External static pressure.

3D095524B

FBA100A

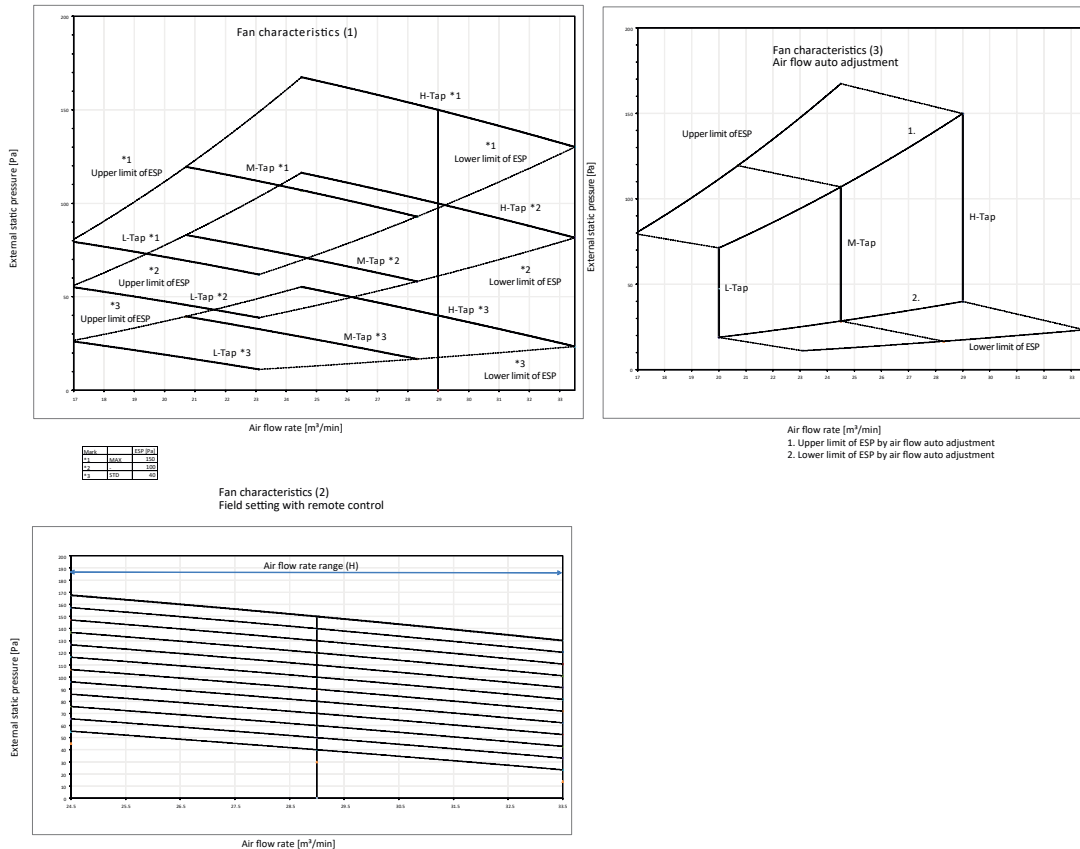

Notes:
 1. Fan characteristics as shown are in "fan only" mode.
 2. ESP: External static pressure.

3D095526B



FBA125-140A

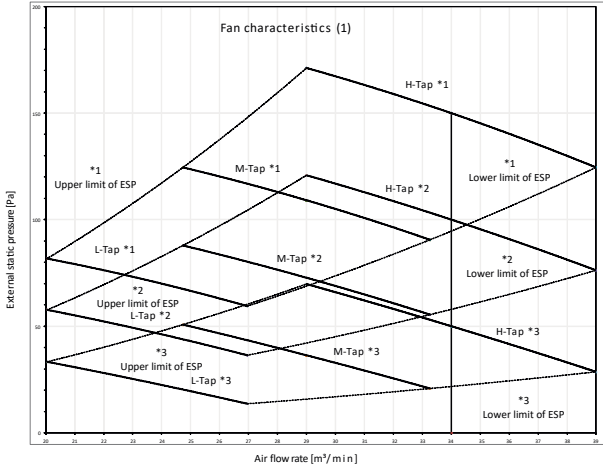

Speed	ESP (Pa)
*1	250
*2	160
*3	90

Fan characteristics (2)
Field setting with remote control

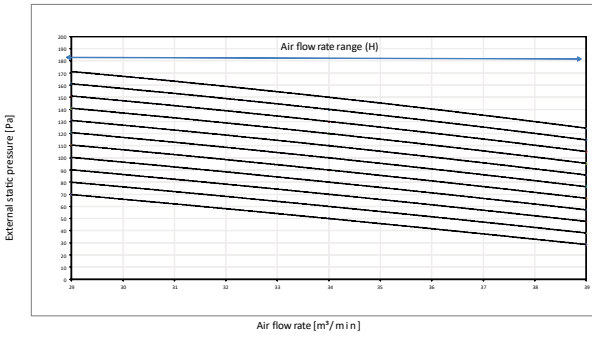

Notes:

- 1. Fan characteristics as shown are in "fan only" mode.
- 2. ESP: External static pressure.

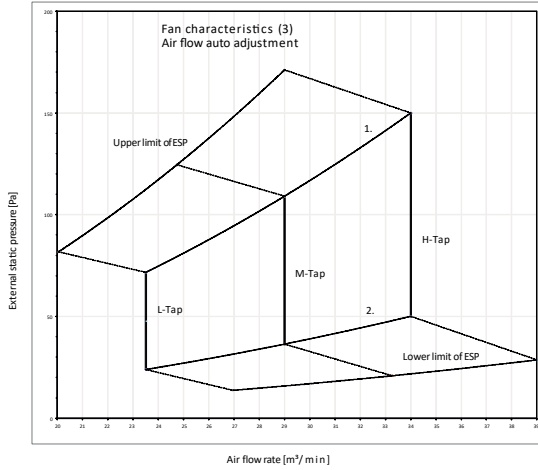

- 1. Upper limit of ESP by air flow auto adjustment
- 2. Lower limit of ESP by air flow auto adjustment

3D095527B



FDA125A

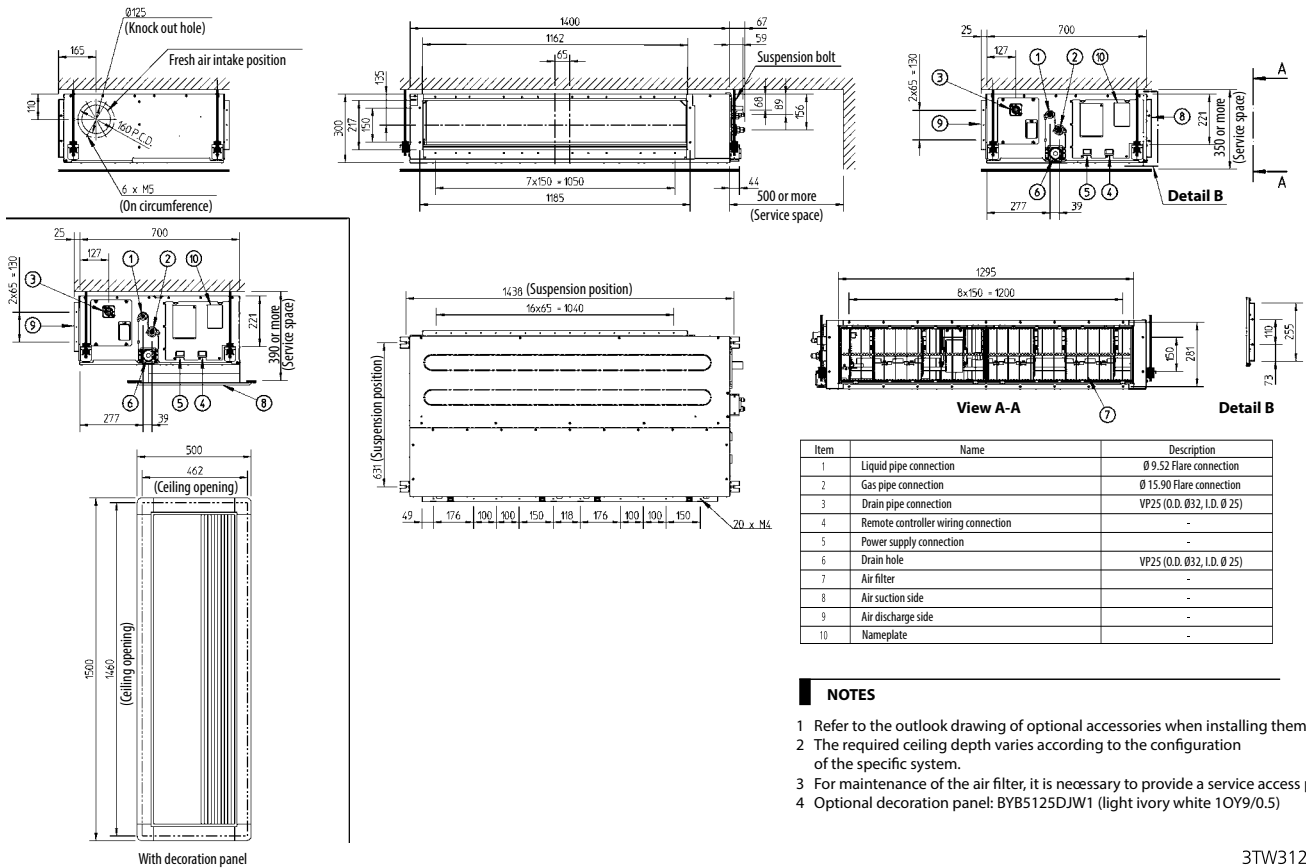

FDA125A

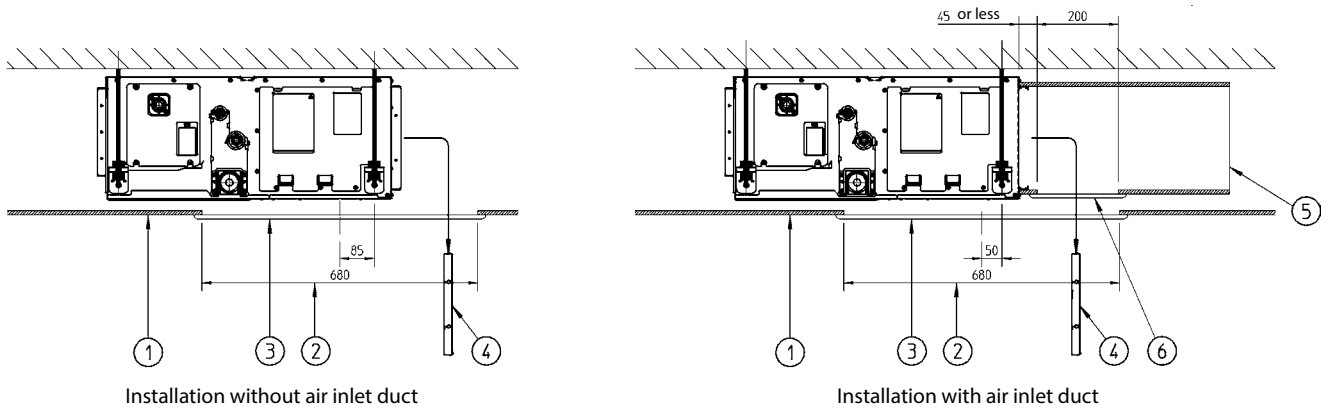

Number	Description
1	Suspended ceiling
2	Ceiling opening
3	Service access panel (optional)
4	Air filter
5	Air inlet duct
6	Duct service opening

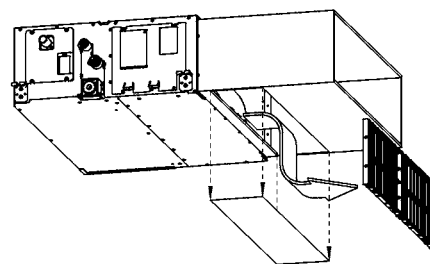

NOTES

- 1 When installing the unit with rear suction, a service opening is necessary for the maintenance of the air filters.
- 2 When installing the unit with a suction duct, a service opening must be provided in the duct.

3TW31184-4



FDA-A

Fan characteristics (1)

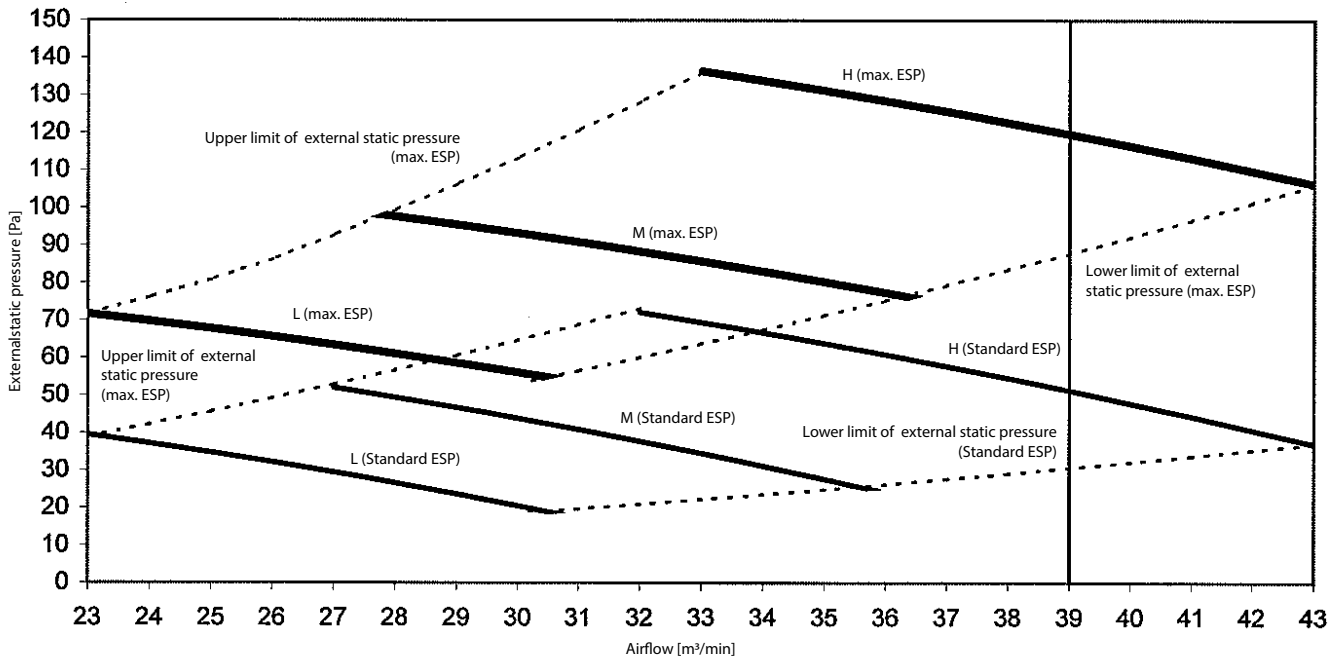

NOTES

- 1. The fan characteristics shown are in "fan only" mode.
- 2. ESP: External Static Pressure

3TW31268-1

FDA-A

Fan characteristics (2)
(Field setting with remote controller)
range of available air flow rate (H)

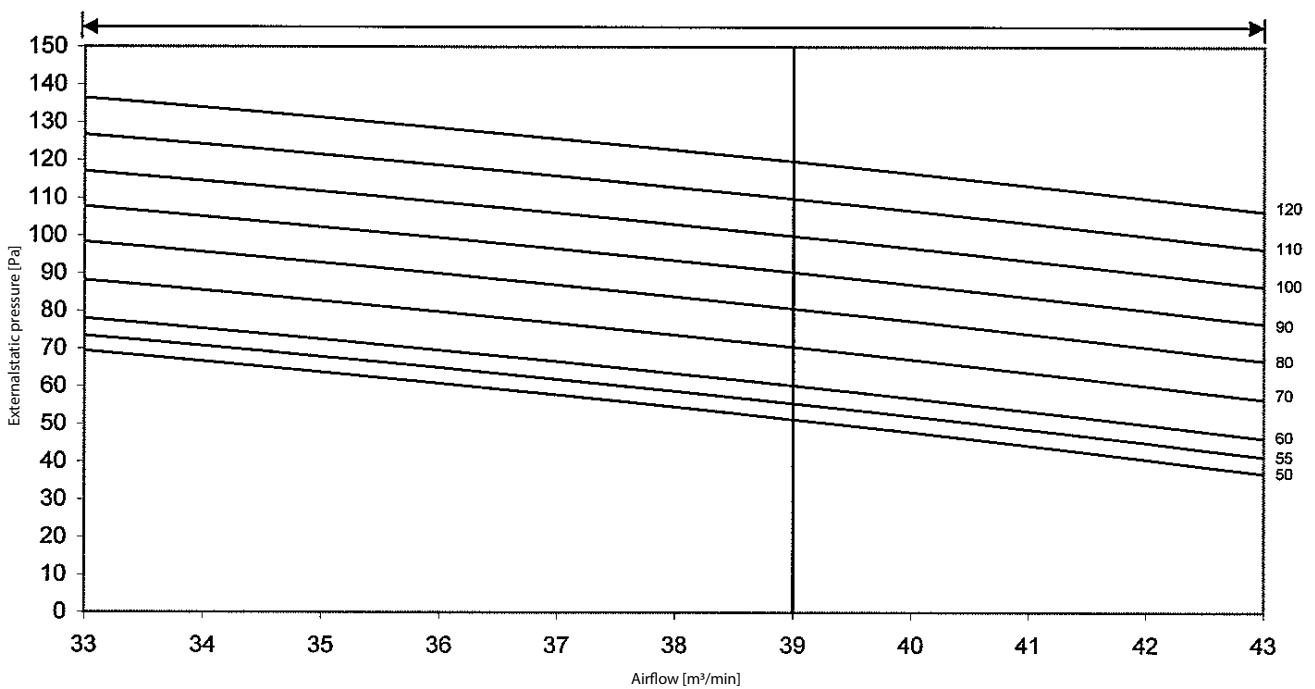

NOTES

- 1. The fan characteristics shown are in "fan only" mode.
- 2. ESP: External Static Pressure

3TW31268-1



FDA-A

Fan characteristics (3)
(air flow auto adjustment)

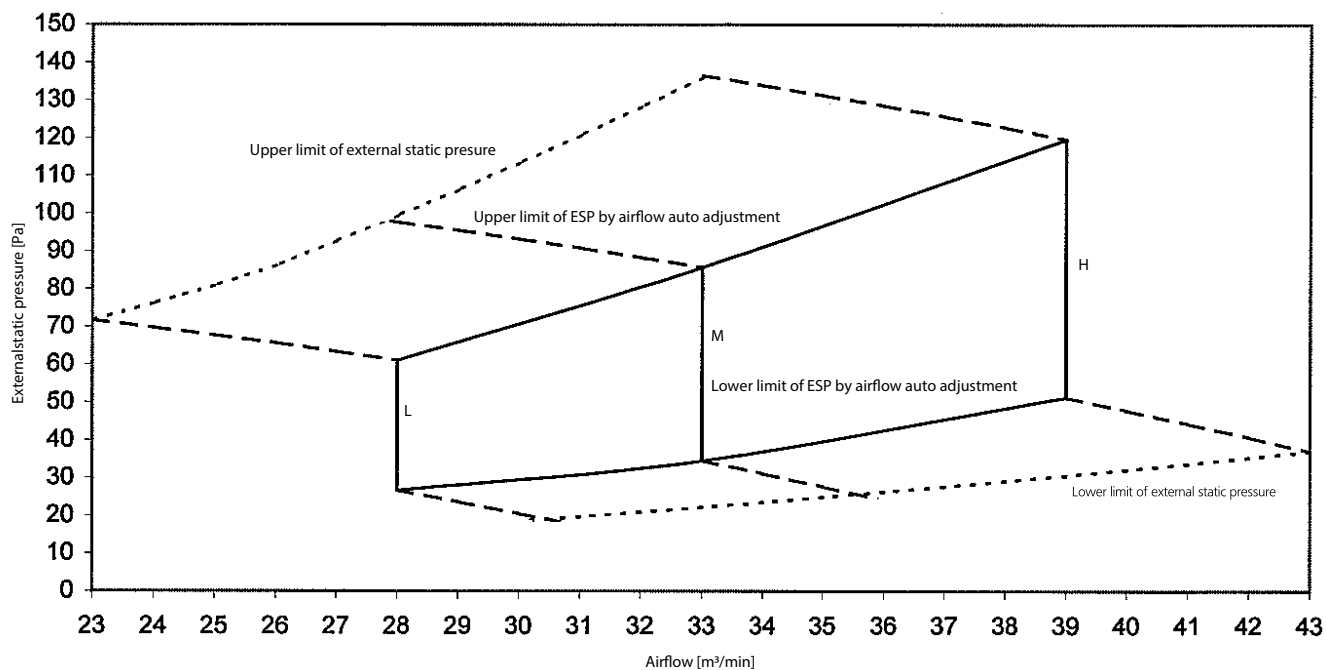

NOTES

- 1. The fan characteristics shown are in "fan only" mode.
- 2. ESP: External Static Pressure

3TW31268-1



FDQ200-250B

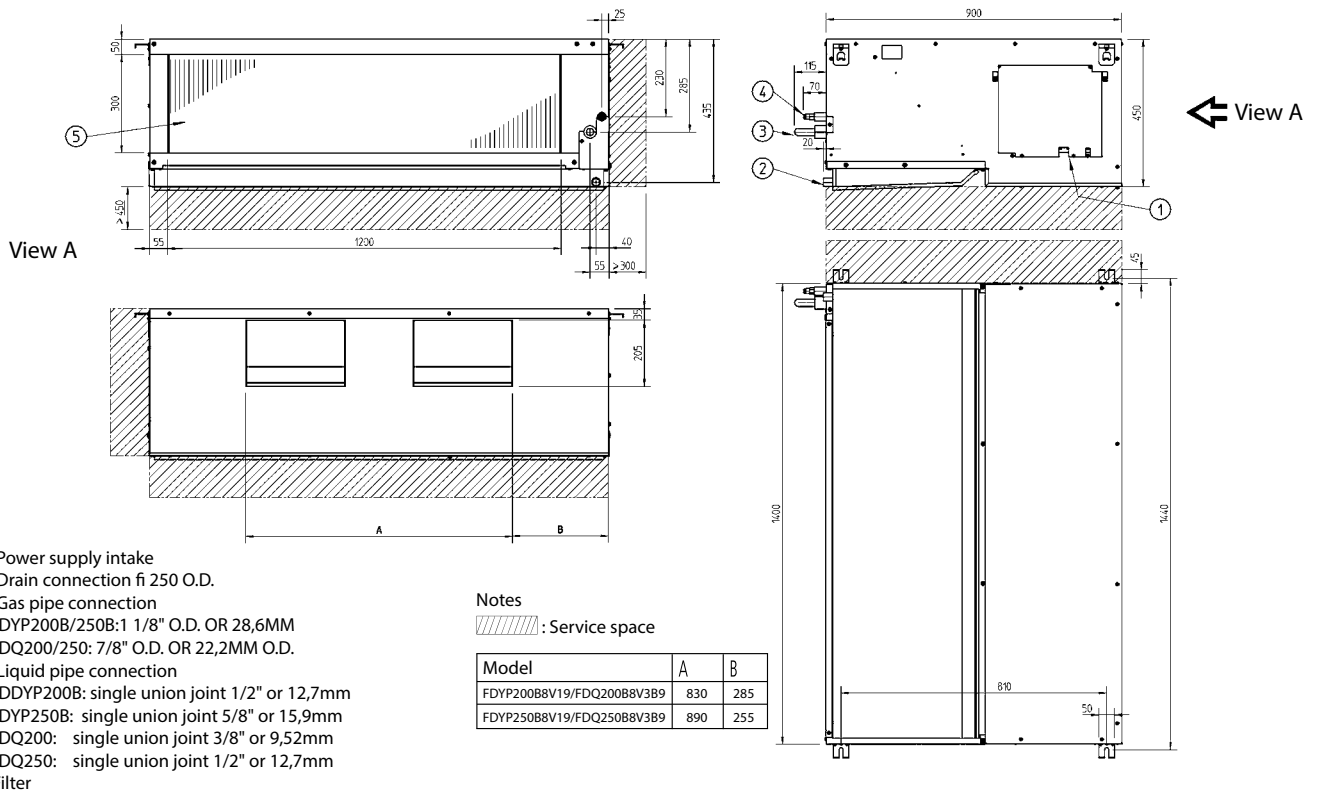

3TW30844-1

FDQ200B7

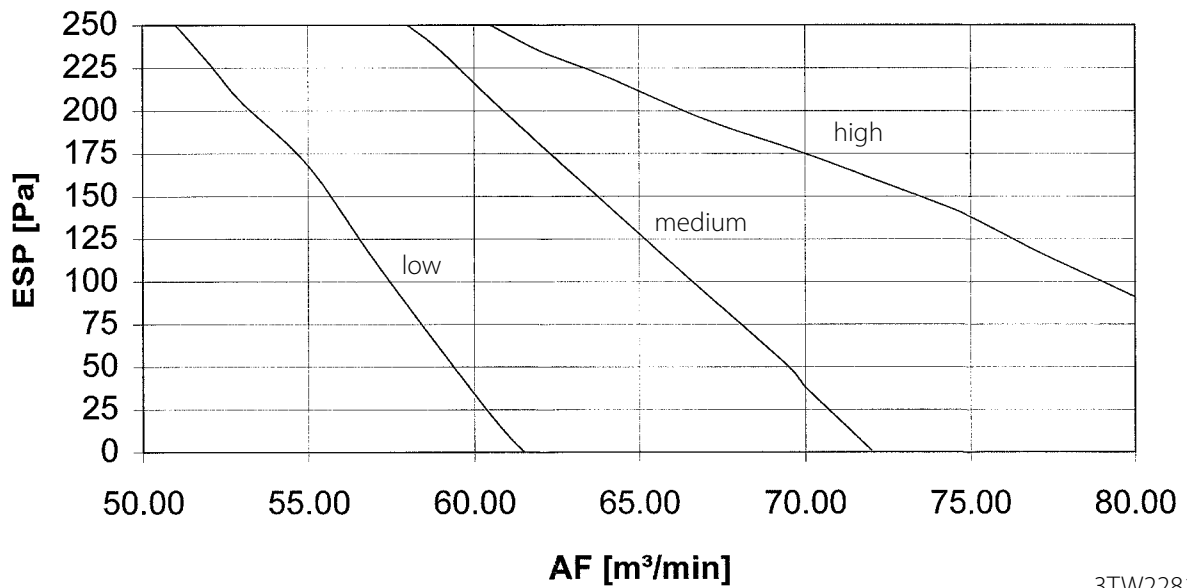

3TW22818-1



FDQ200B7

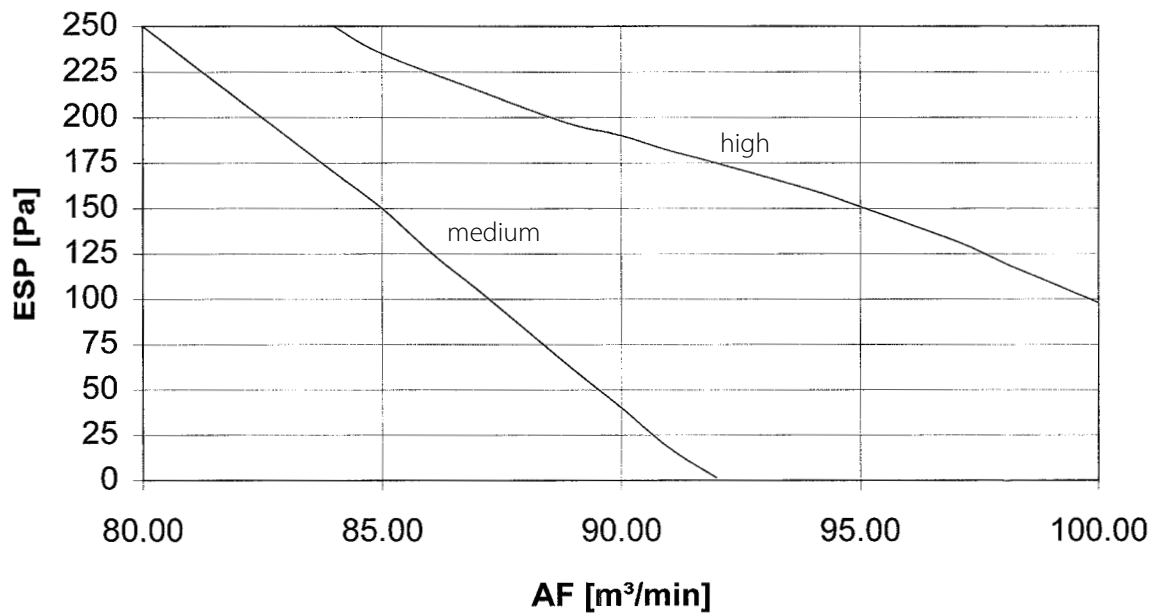

3TW22828-1



ABQ71C

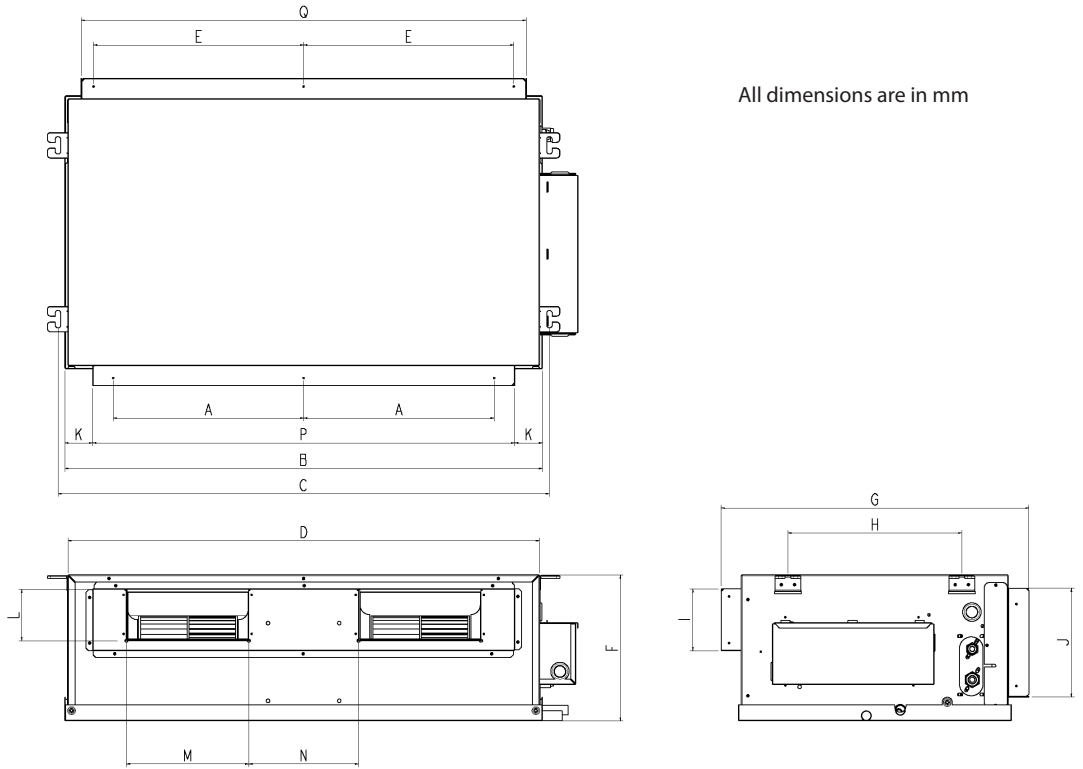

All dimensions are in mm

Model	Dimension	A	B	C	D	E	F	G	H	I	J	K	L	M	N	P	Q
ABQ71C		372	1001	959	920	410	285	600	339	121	231	54	100	245	216	824	869

ABQ100-140C

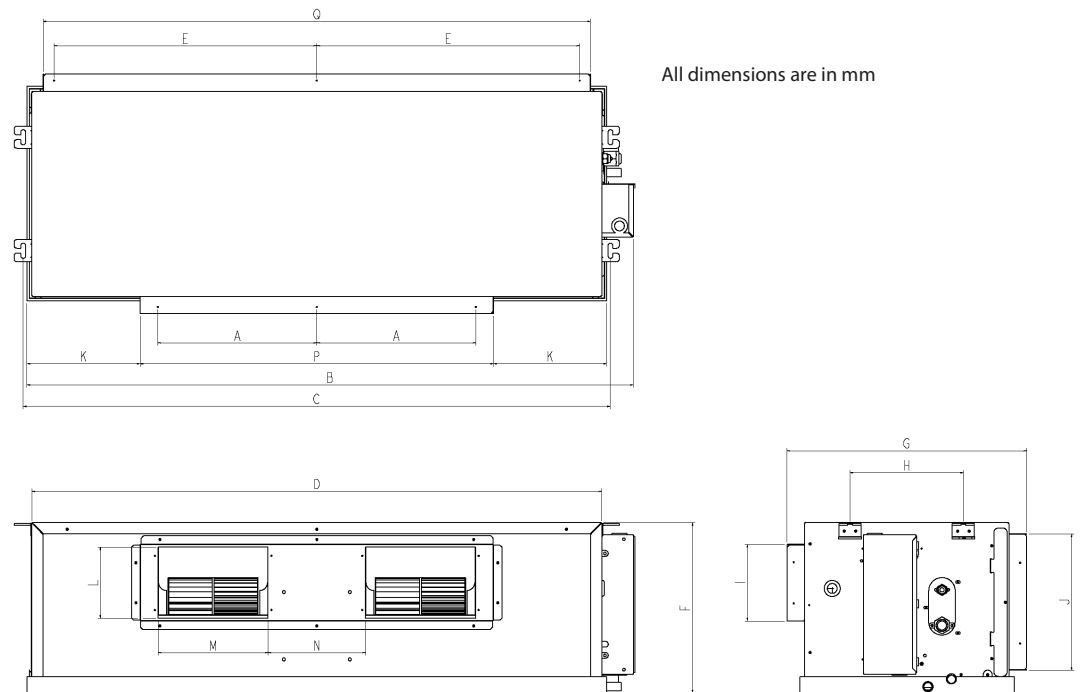

All dimensions are in mm

Model	Dimension	A	B	C	D	E	F	G	H	I	J	K	L	M	N	P	Q
ABQ100C		359	1115	1072	1033	467	378	541	256	180	306	128	170	234	234	798	982
ABQ125C		359	1369	1326	1287	594	378	541	256	180	306	256	170	234	234	798	1236
ABQ140C		359	1569	1526	1487	694	378	541	256	180	306	356	170	234	234	789	1436

ABQ71C

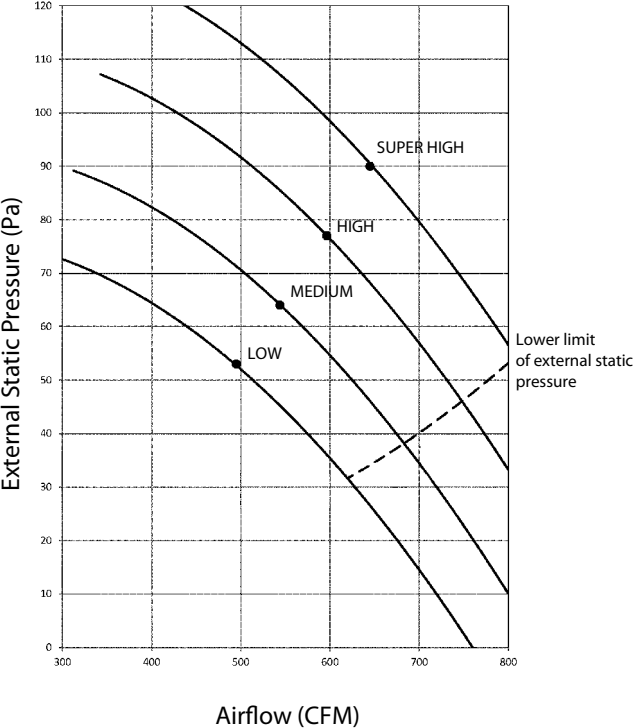

ABQ100C

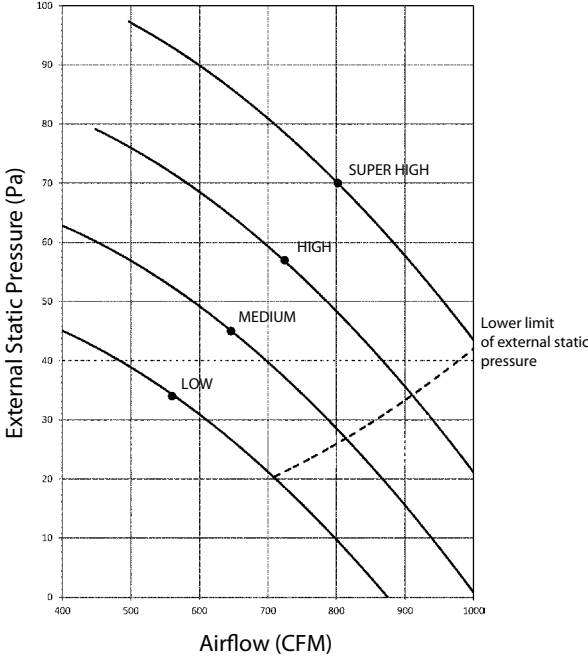

2056-014

ABQ125C

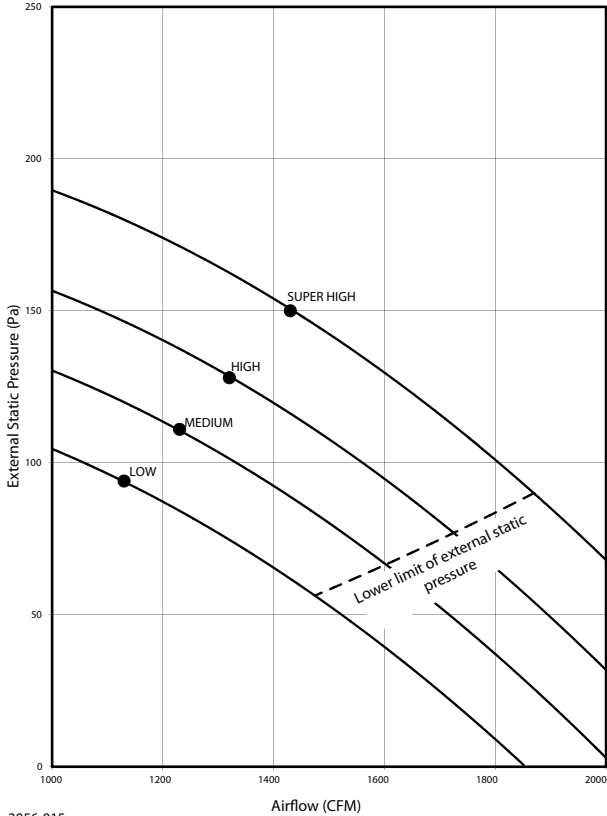

2056-015

ABQ140C

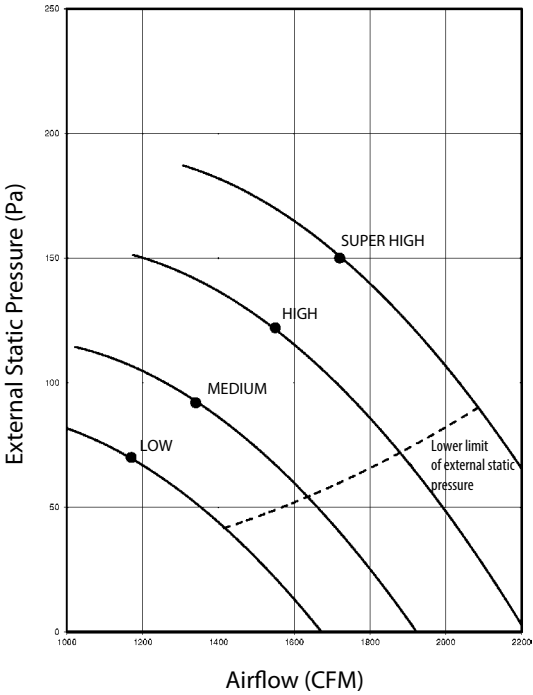

2056-016



Detailed technical drawings

FAA71A

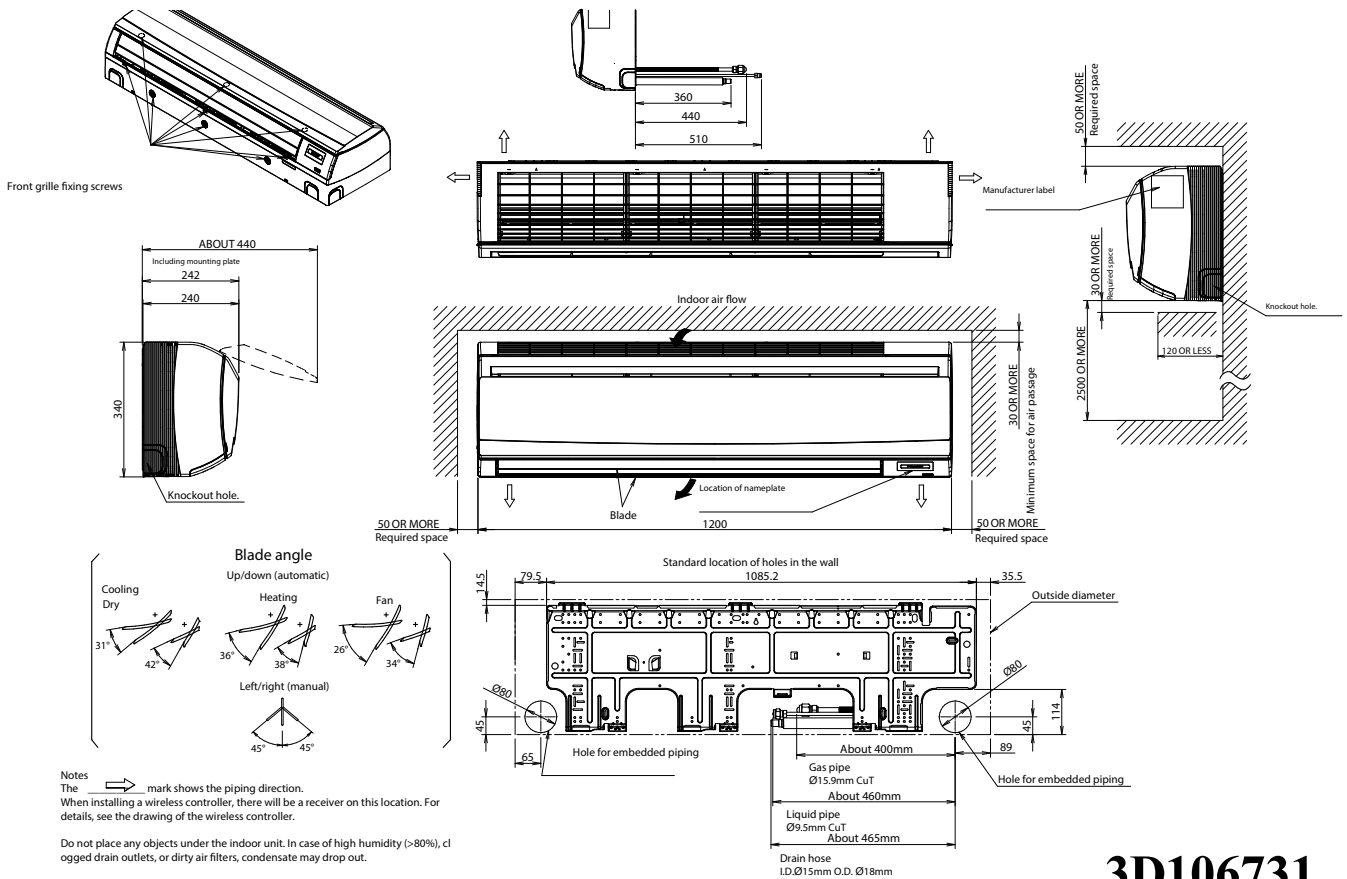

3D106731

FAA100A

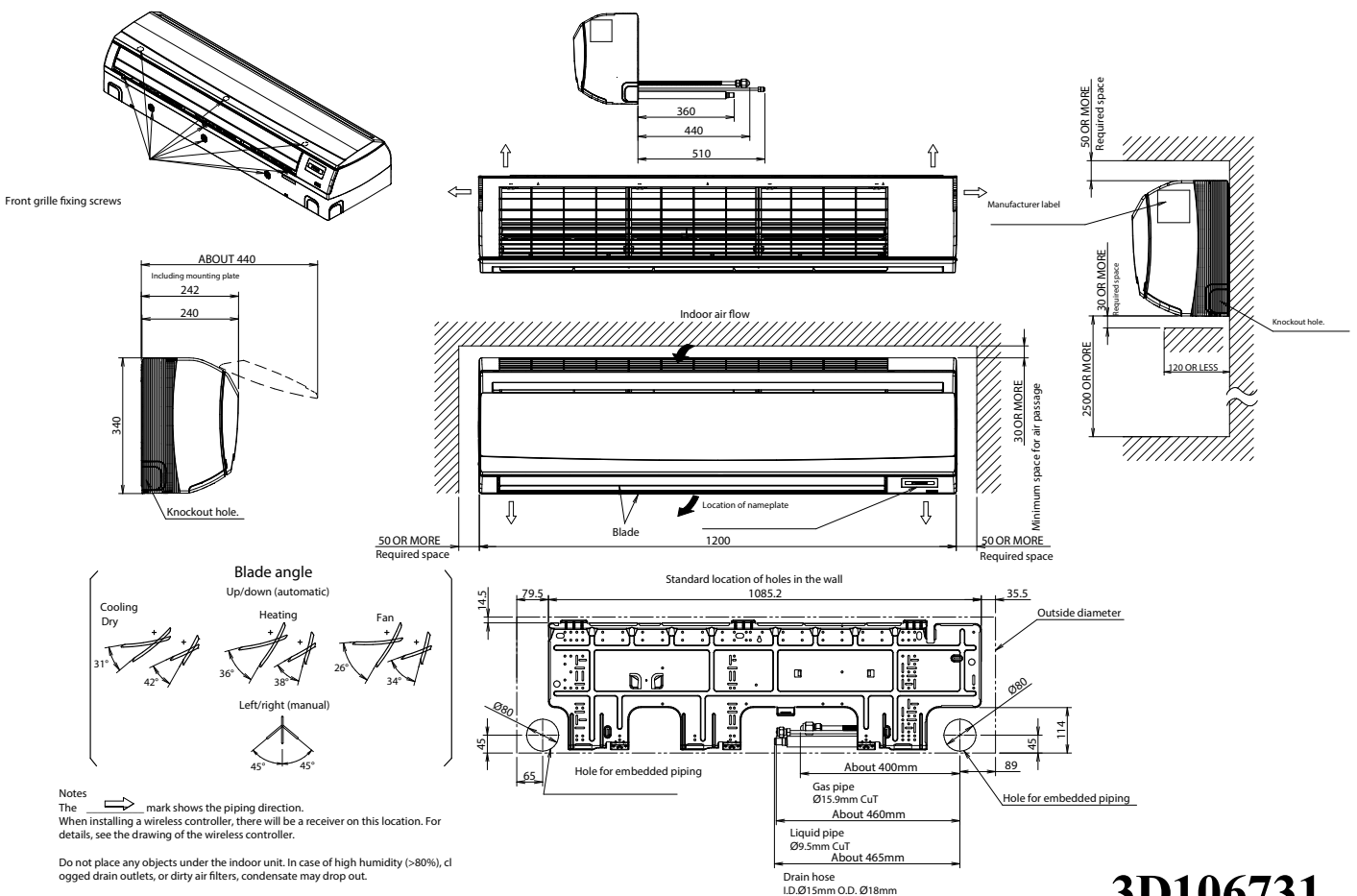

3D106731



FHA35A

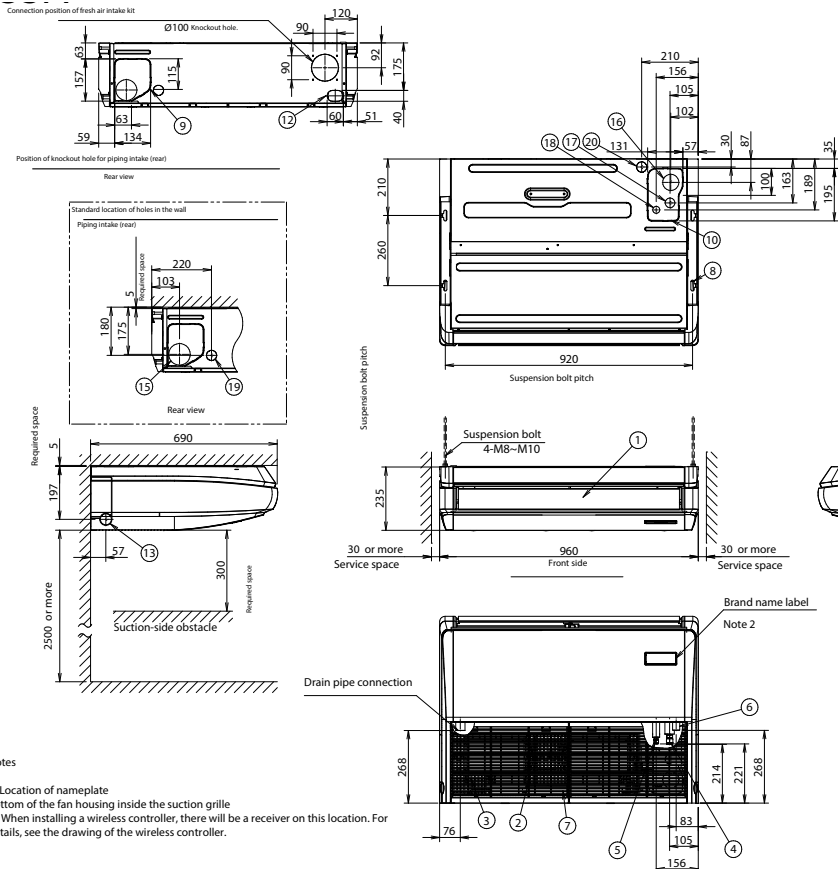

Number	Name	Description
1	Air discharge grille	
2	Air suction grille	
3	Air filter	
4	Gas pipe connection Ø12.7 flare	
5	Liquid pipe connection Ø6.4 flare	
6	Drain pipe connection	VP20
7	Terminal block with earth terminal Located inside of the unit	M4
8	Metal hanger	
9	Position of knockout hole	Rear side
10	Position of knockout hole	Top
11	Piping intake (right)	Knockout hole
12	Drain piping intake (left-rear)	Knockout hole
13	Drain piping intake (left)	Knockout hole
14	Drain piping intake (right)	Knockout hole
15	Standard location of holes in the wall Piping intake (rear)	Ø100
16	Drain piping intake (top)	Ø60
17	Gas piping intake (top)	Ø36
18	Liquid piping intake (top)	Ø26
19	Power supply wiring and control wiring intake (rear)	Ø29
20	Power supply wiring and control wiring intake (top)	Ø29

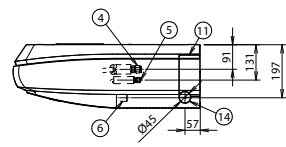

Notes

1) Location of nameplate
Bottom of the fan housing inside the suction grille

2) When installing a wireless controller, there will be a receiver on this location. For details, see the drawing of the wireless controller.

3) Do not place any objects under the indoor unit. In case of high humidity (>80%), clogged drain outlets, or dirty air filters, condensate may drop out.

3D106574A

FHA50A

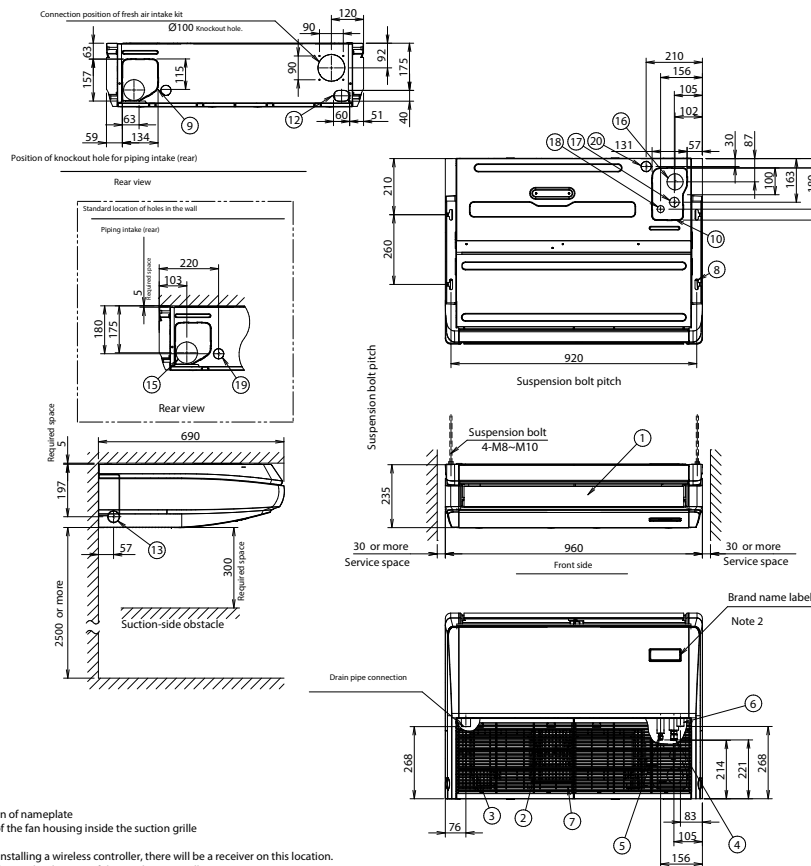

Number	Name	Description
1	Air discharge grille	
2	Air suction grille	
3	Air filter	
4	Gas pipe connection Ø12.7 flare	
5	Liquid pipe connection Ø6.4 flare	
6	Drain pipe connection	VP20
7	Terminal block with earth terminal Located inside of the unit	M4
8	Metal hanger	
9	Position of knockout hole	Rear side
10	Position of knockout hole	Top
11	Piping intake (right)	Knockout hole
12	Drain piping intake (left-rear)	Knockout hole
13	Drain piping intake (left)	Knockout hole
14	Drain piping intake (right)	Knockout hole
15	Standard location of holes in the wall Piping intake (rear)	Ø100
16	Drain piping intake (top)	Ø60
17	Gas piping intake (top)	Ø36
18	Liquid piping intake (top)	Ø26
19	Power supply wiring and control wiring intake (rear)	Ø29
20	Power supply wiring and control wiring intake (top)	Ø29

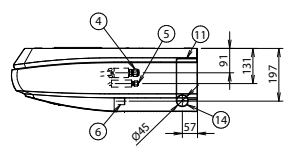

Notes

1) Location of nameplate
Bottom of the fan housing inside the suction grille

2) When installing a wireless controller, there will be a receiver on this location. For details, see the drawing of the wireless controller.

3) Do not place any objects under the indoor unit. In case of high humidity (>80%), clogged drain outlets, or dirty air filters, condensate may drop out.

3D109224A



Detailed technical drawings

FHA60A

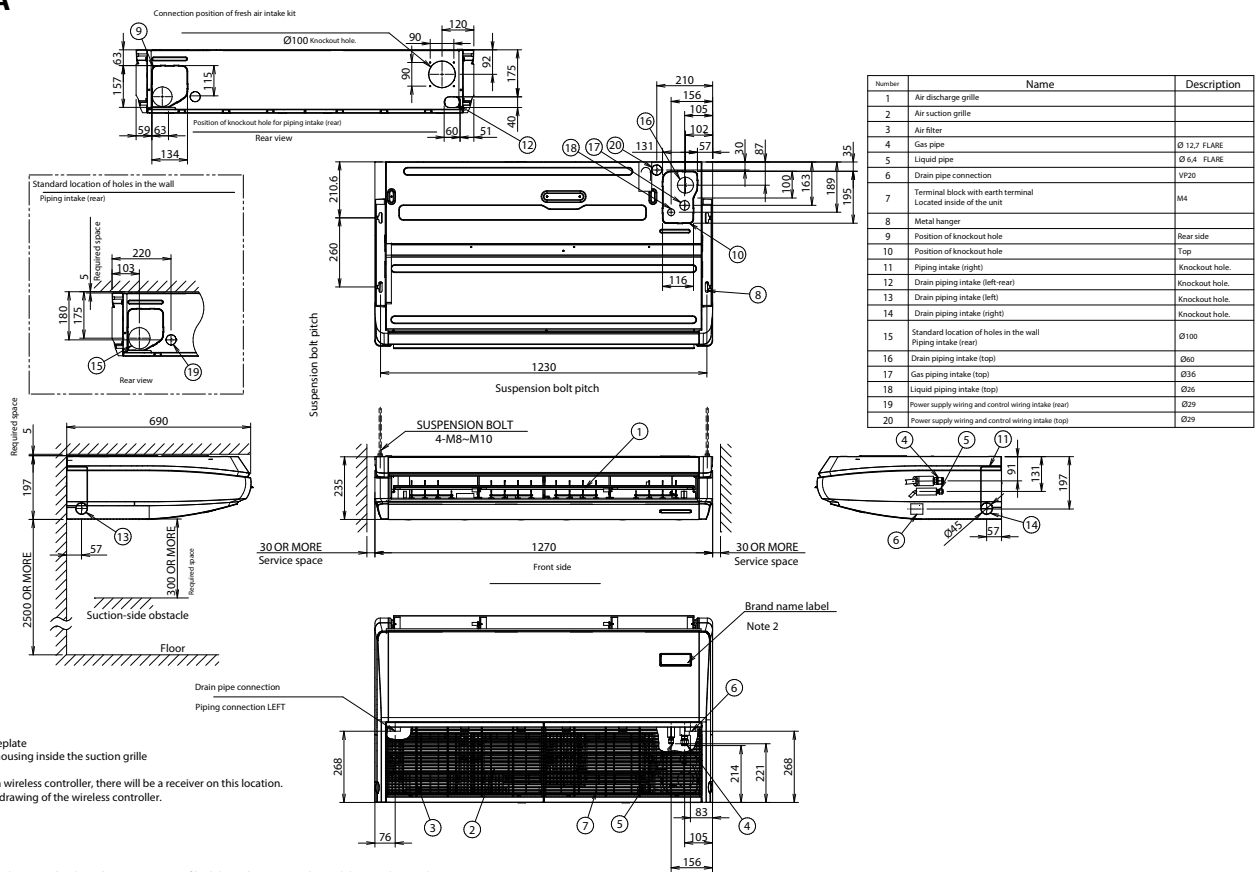

3D106552

FHA71A

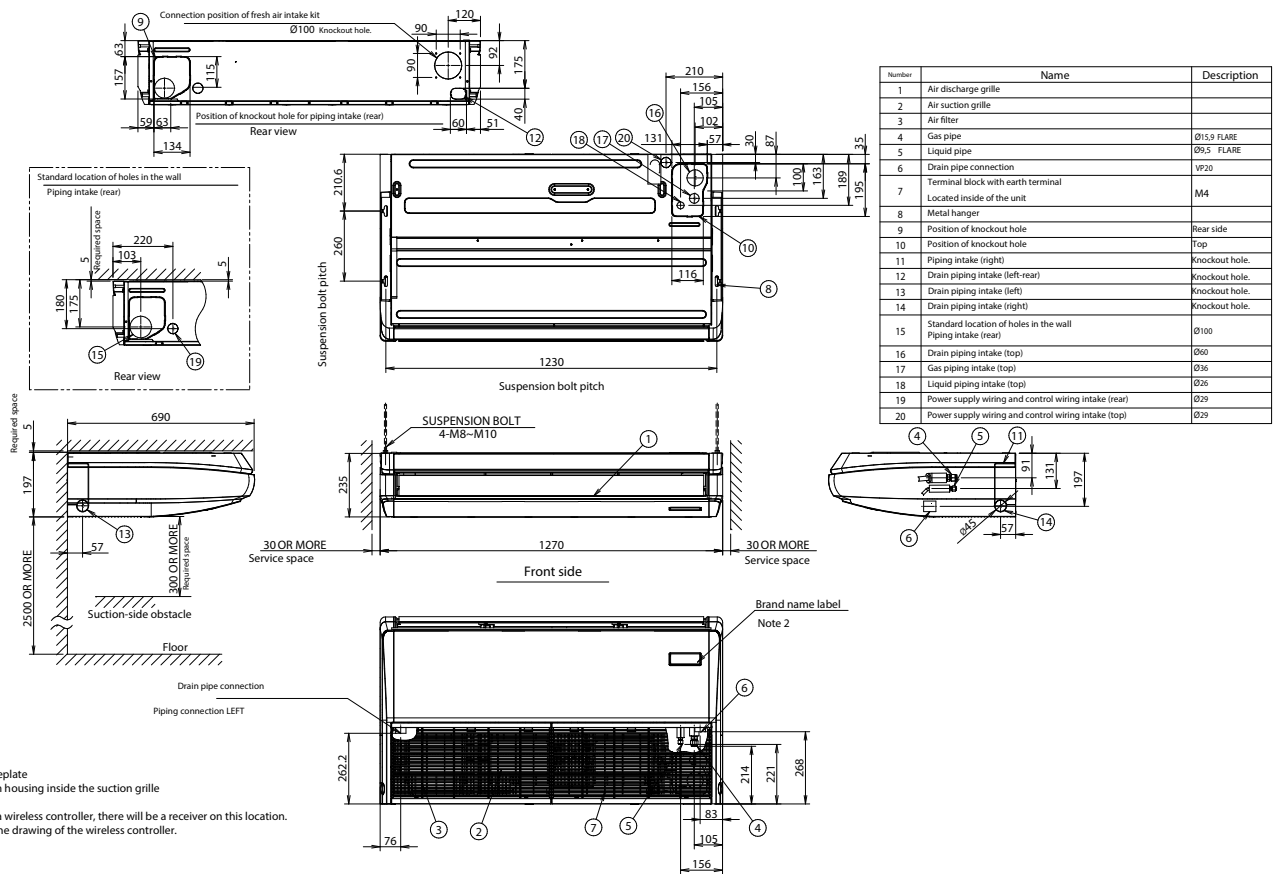

3D109222



FHA100-140A

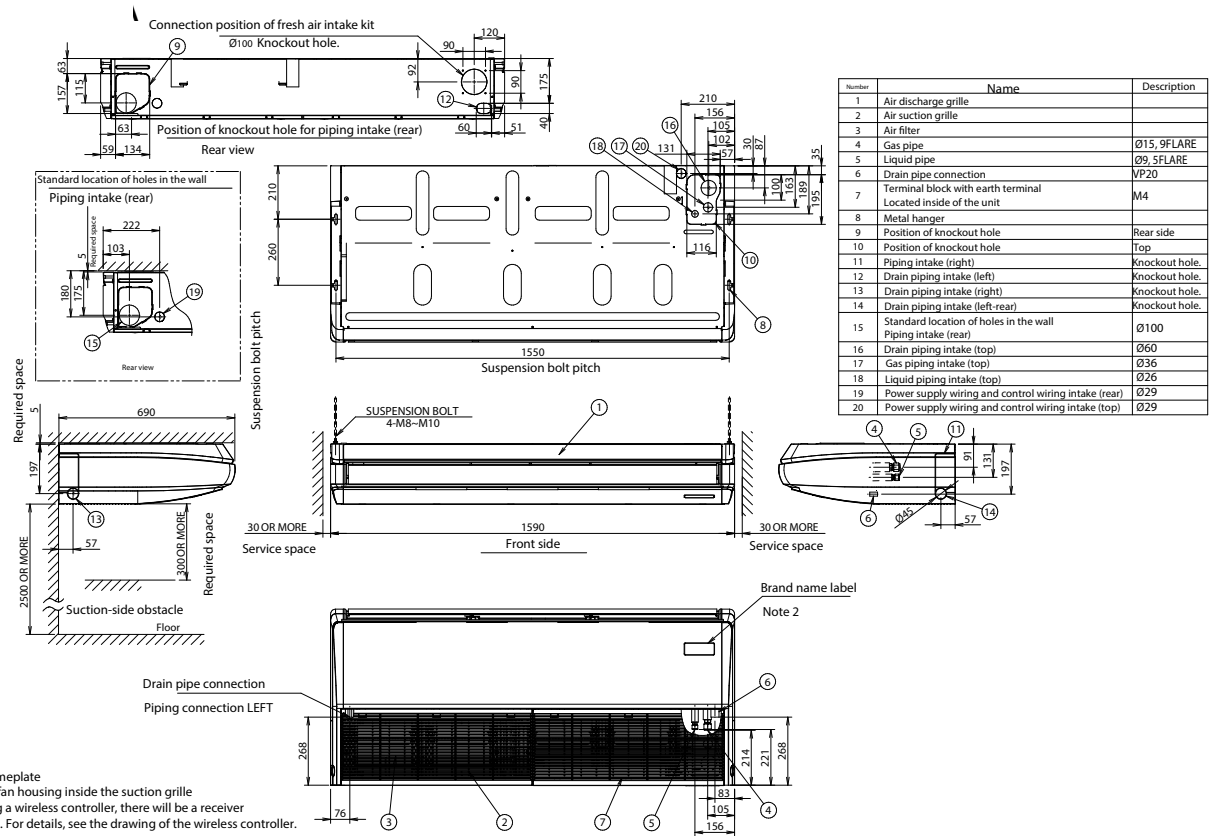

3D106530A



AHQ71-125C

All dimensions are in mm

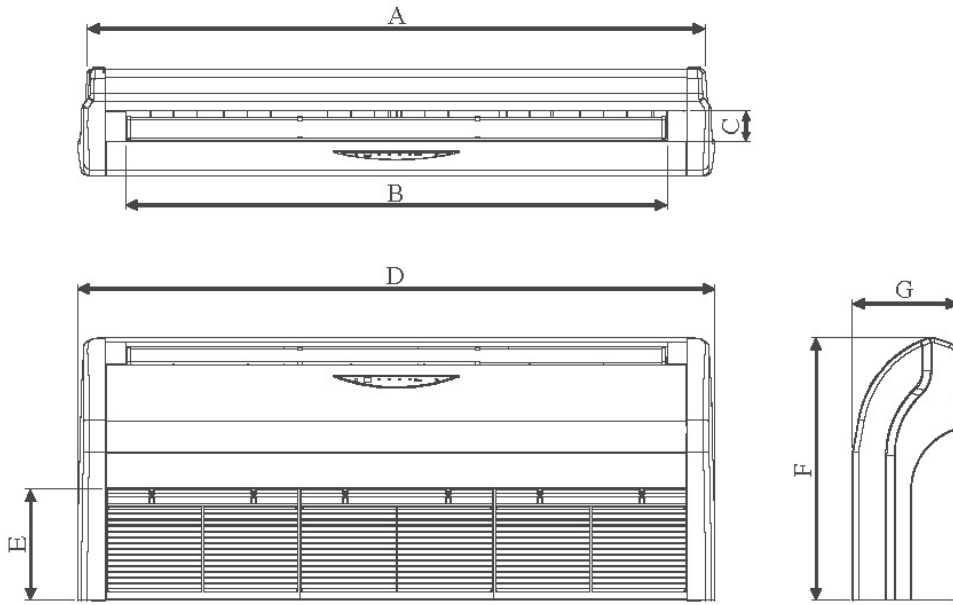

Model	Dimension						
	A	B	C	D	E	F	G
AHQ71C	1272	1088	74	1320	268	635	259
AHQ100C	1490	1308	74	1538	268	635	259
AHQ125C	1738	1556	74	1786	268	635	259

AHQ140C

All dimensions are in mm

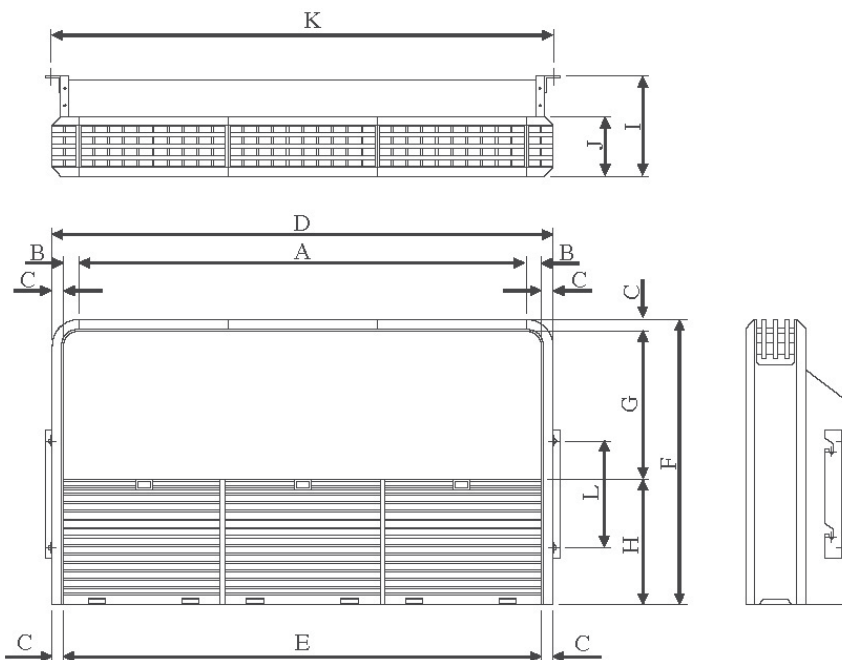

Model	Dimension											
	A	B	C	D	E	F	G	H	I	J	L	L
AHQ140C	1750	40	36	1903	1830	680	352	292	285	140	1880	250



FUA-A

Notes

- 1.The unit nameplate is located on the control box cover.
- 2.When installing a wireless controller, there will be a receiver on this location. For details, see the drawing of the wireless controller.
- 3.When closing the discharge grille in case of 2-way blow or 3-way blow, there are limitations to the piping connection direction. See the installation manual.
- 4.Do not place any objects under the indoor unit. In case of high humidity (>80%), clogged drain outlets, or dirty air filters, condensate may drop out.

When closing the air outlet, the required space is 30mm or more. Note (3)

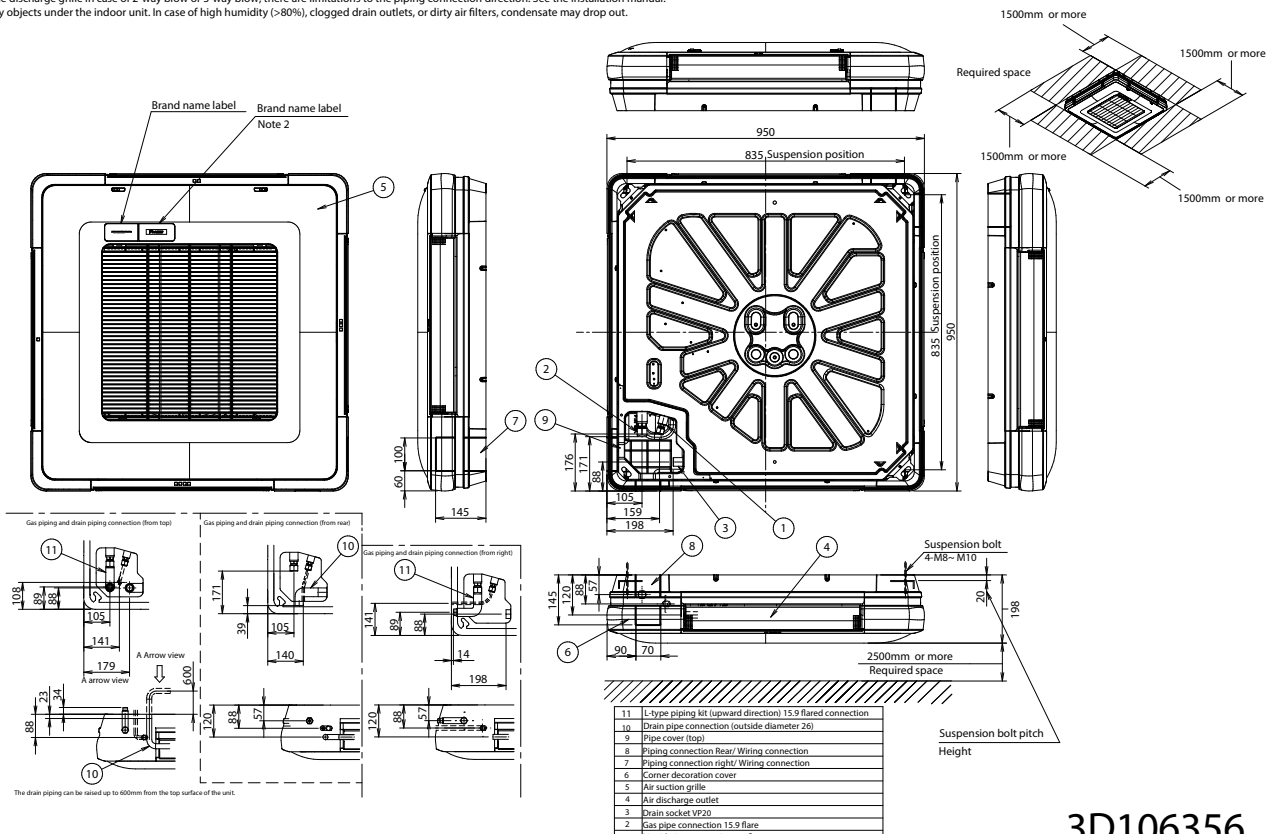



FVA71A

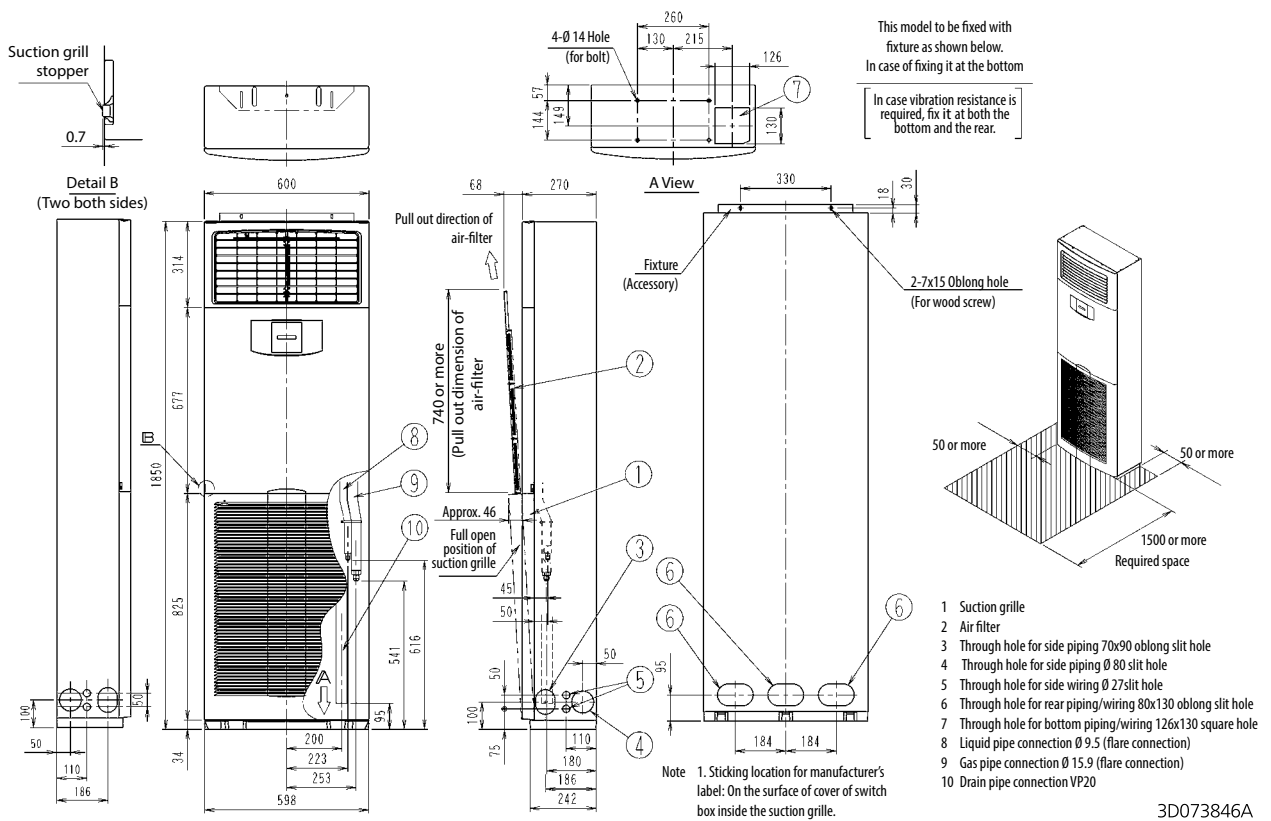

FVA100-125-140A

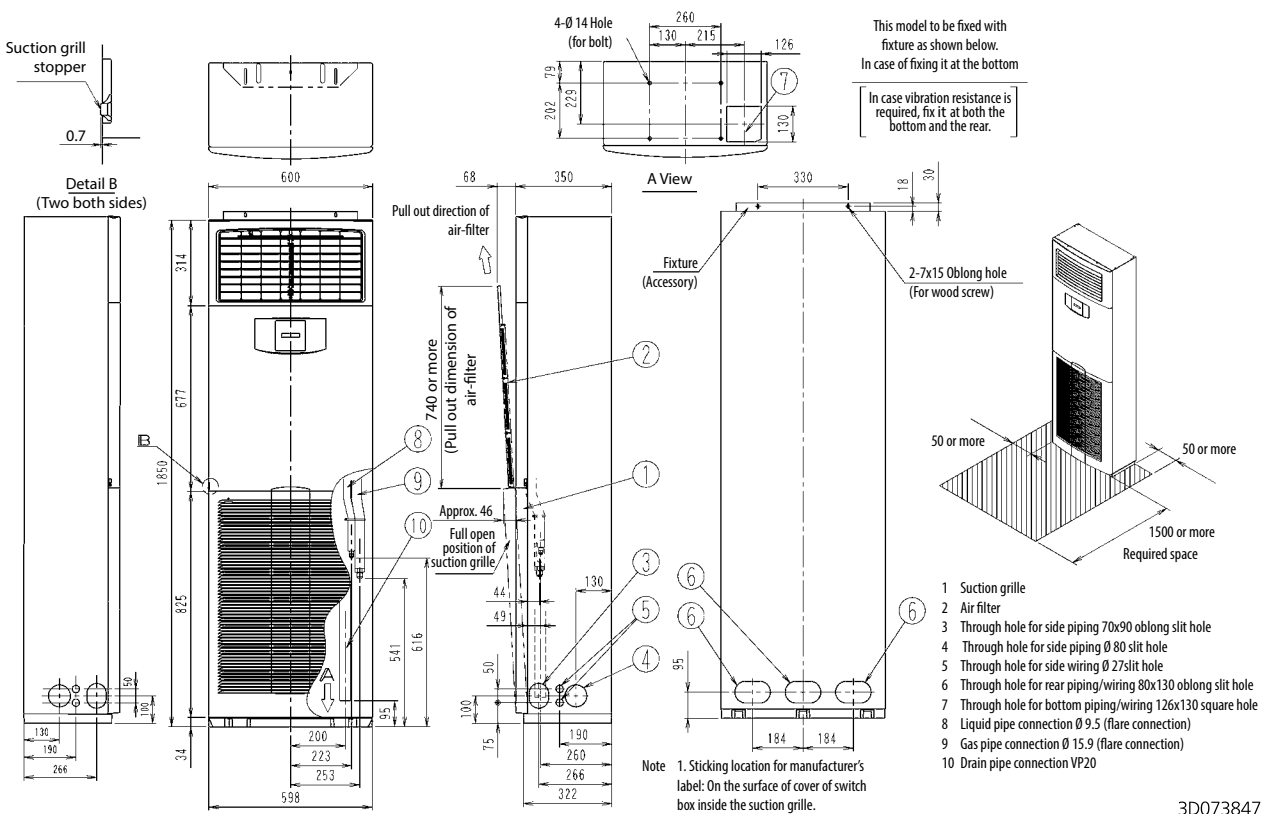



FNA25-35A

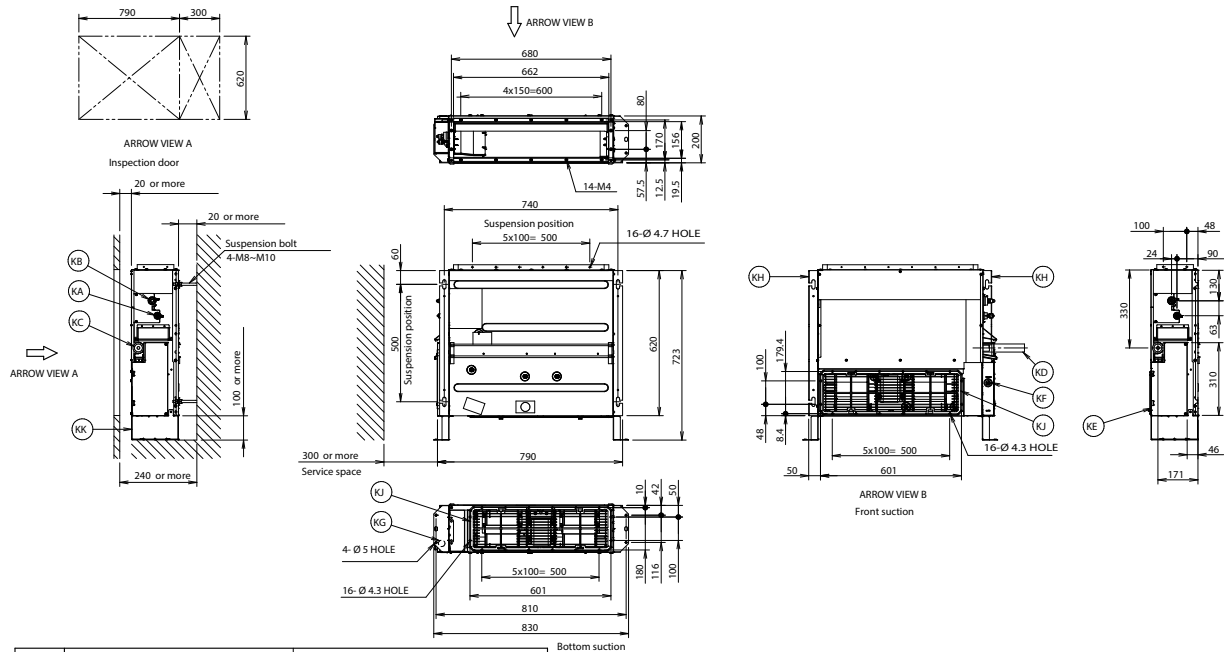

Item	Name	Description
KA	Liquid pipe connection port	Ø 6.40 flared connection
KB	Gas pipe connection port	Ø 9.50 flared connection
KC	Drain pipe connection	VP20 (OD Ø26, ID Ø20)
KD	Drain hose	ID Ø25
KE	Control box	/
KF	Transmission line	/
KG	Power supply connection	/
KH	Suspension bracket	/
KJ	Air filter	/
KK	Mounting foot	/

Notes
 1. When installing optional accessories, refer to their respective documentation.
 2. The ceiling depth varies according to the documentation of the specific system.

3D096751

FNA50-60A

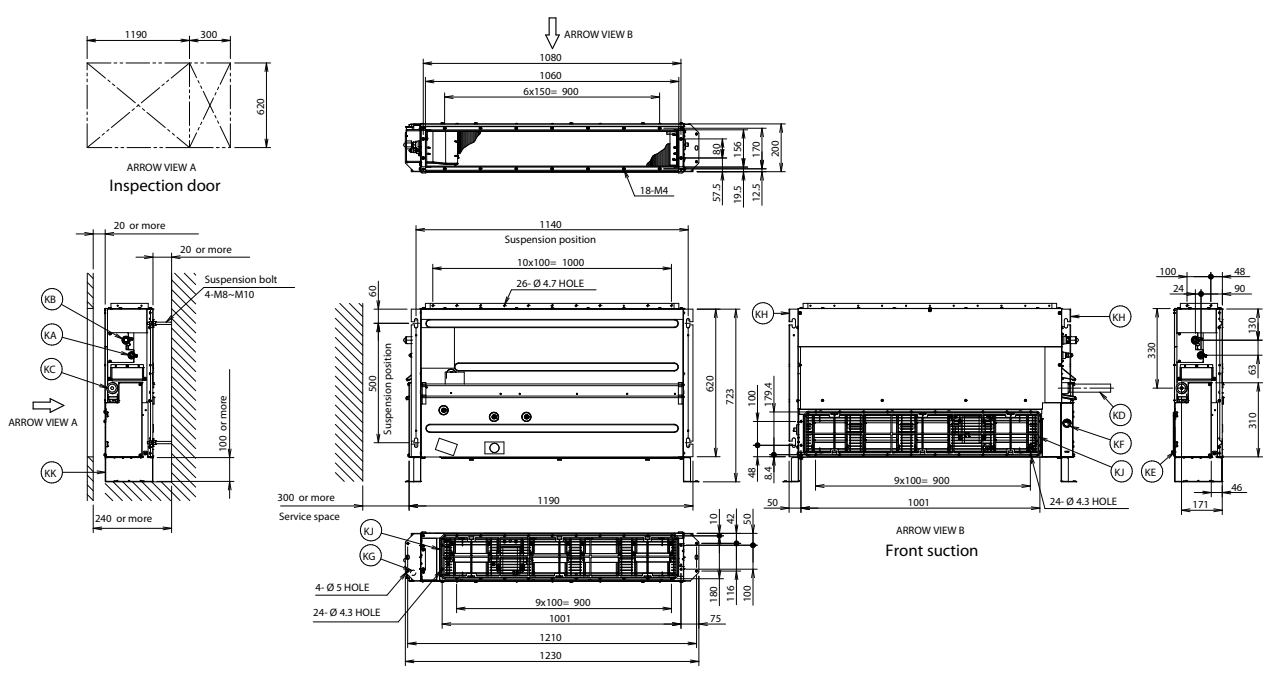

Item	Name	Description
KA	Liquid pipe connection port	Ø6.4 flared connection
KB	Gas pipe connection port	Ø12.70 flared connection
KC	Drain pipe connection	VP20 (OD Ø26, ID Ø20)
KD	Drain hose	ID Ø25
KE	Control box	/
KF	Transmission line	/
KG	Power supply connection	/
KH	Suspension bracket	/
KJ	Air filter	/
KK	Mounting foot	/

Notes
 1. When installing optional accessories, refer to their respective documentation.
 2. The ceiling depth varies according to the documentation of the specific system.

3D096750

FNA25-35A

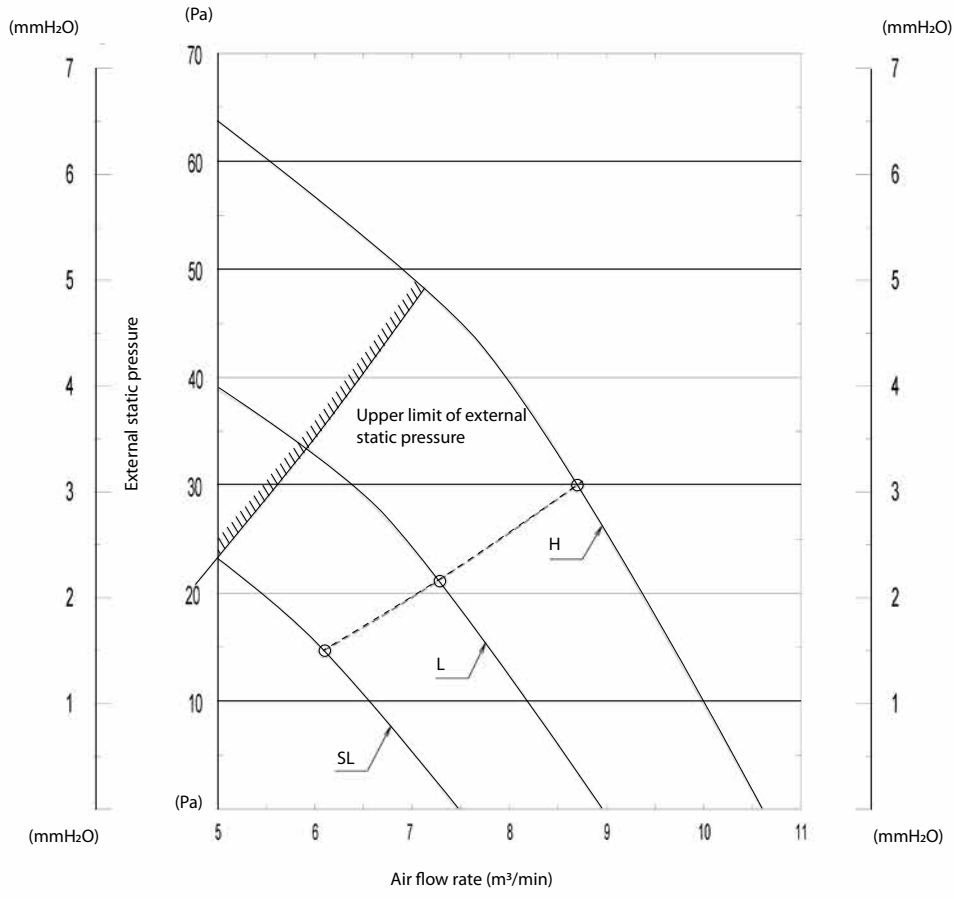

3D081327A

FNA50A

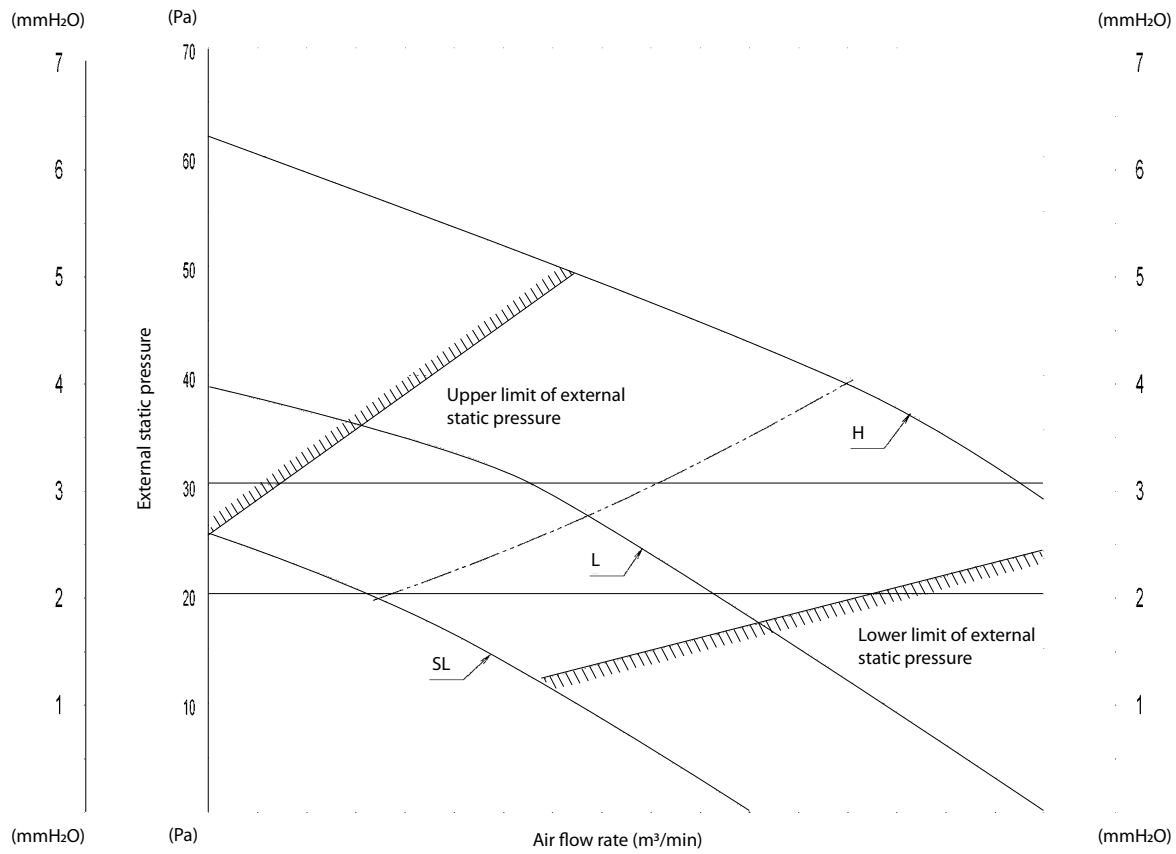

3D085960A



FNA60A

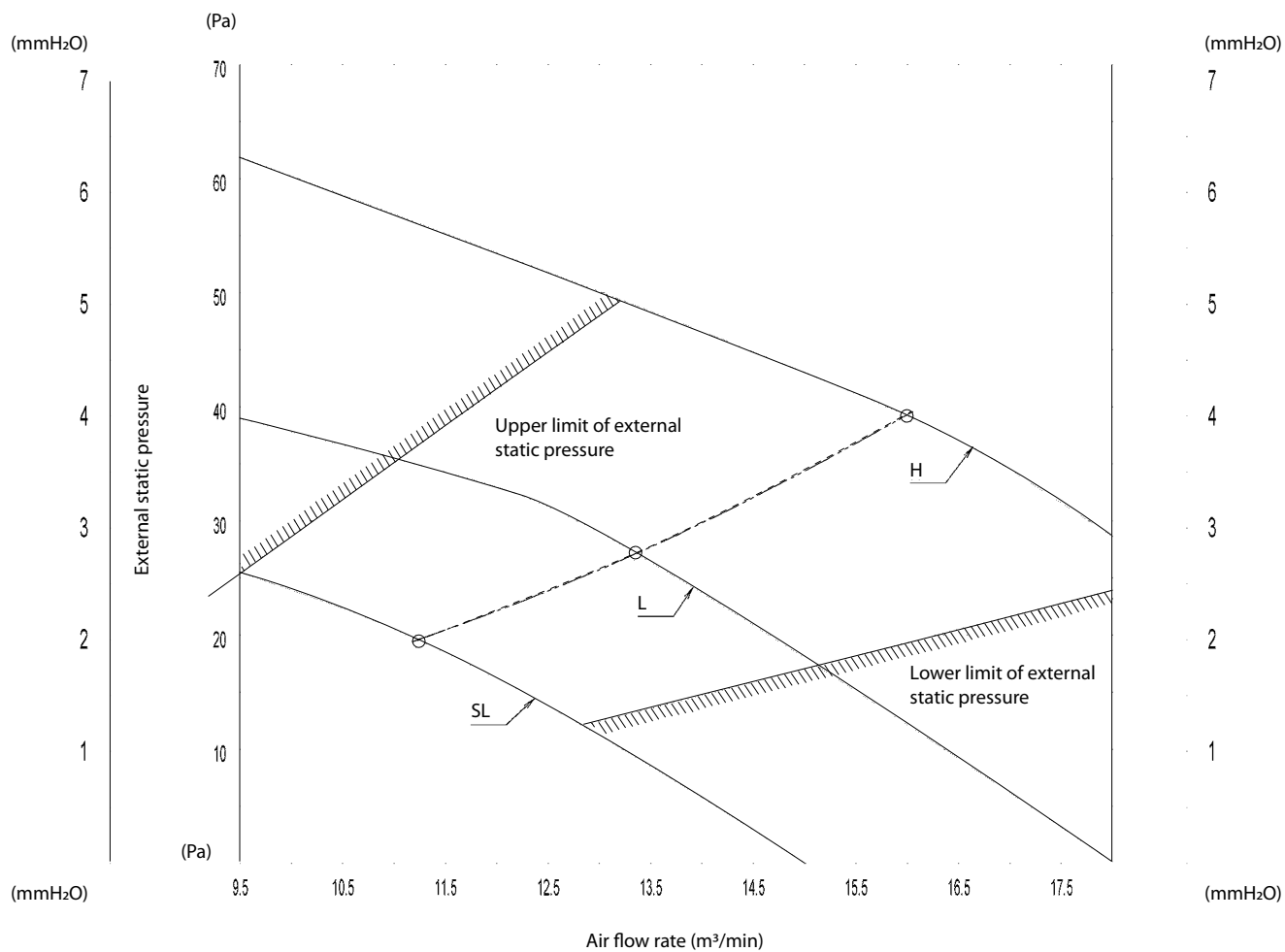

3D081329A

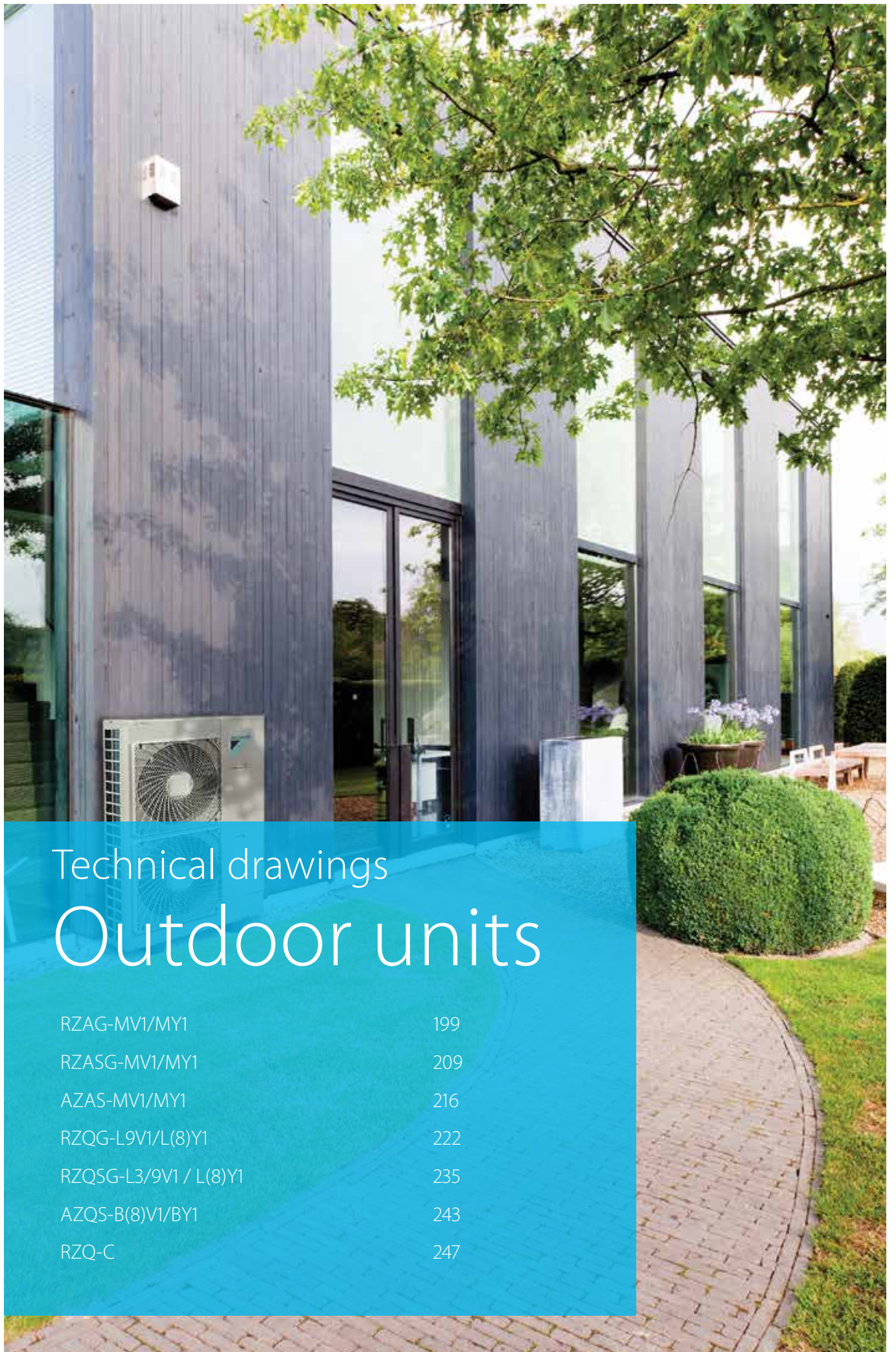

Technical drawings

Outdoor units

RZAG-MV1/MY1	199
RZASG-MV1/MY1	209
AZAS-MV1/MY1	216
RZQG-L9V1/L(8)Y1	222
RZQSG-L3/9V1 / L(8)Y1	235
AZQS-B(8)V1/BY1	243
RZQ-C	247



RZAG71-100MV1 COMFORT COOLING

Indoor	Outdoor	Power supply	Voltage range	MCA	TOCA	MFA	Compressor		OFM		IFM		
							MSC	RLA	kW	FLA	kW	FLA	
FCAHG71GVEB	RZAG71M7V1B	50Hz~ 220- 240V	Minimum: 198 V	Maximum: 264 V	17.5	-	20	-	15.5	0.094	0.8	0.091	0.5
FCAG35AVEB	x2 RZAG71M7V1B				17.6	-	20	-	15.5	0.094	0.8	0.044x2	0.3x2
FCAG71AVEB	RZAG71M7V1B				17.4	-	20	-	15.5	0.094	0.8	0.054	0.4
FFA35A2VEB	x2 RZAG71M7V1B				17.8	-	20	-	15.5	0.094	0.8	0.050x2	0.4x2
FBA35A2VEB	x2 RZAG71M7V1B				18.2	-	20	-	15.5	0.094	0.8	0.089x2	0.6x2
FBA71A2VEB	RZAG71M7V1B				17.6	-	20	-	15.5	0.094	0.8	0.070	0.5
FNA35A2VEB	x2 RZAG71M7V1B				17.3	-	20	-	15.5	0.094	0.8	0.034x2	0.3
FUA71A1VEB	RZAG71M7V1B				17.9	-	20	-	15.5	0.094	0.8	0.046	0.9
FAA71AUVEB	RZAG71M7V1B				17.4	-	20	-	15.5	0.094	0.8	0.048	0.4
FVA71AMVEB	RZAG71M7V1B				17.6	-	20	-	15.5	0.094	0.8	0.117	0.6
FDXM35F3V1B	x2 RZAG71M7V1B				17.6	-	20	-	15.5	0.094	0.8	0.034x2	0.3x2
FHA35AVEB	x2 RZAG71M7V1B				18.2	-	20	-	15.5	0.094	0.8	0.060x2	0.6x2
FHA71AVEB	RZAG71M7V1B				17.8	-	20	-	15.5	0.094	0.8	0.091	0.8
FCAHG100GVEB	RZAG100M7V1B				27.4	-	32	-	23.5	0.094+0.094	0.75+0.75	0.221	1.3
FCAG35AVEB	x3 RZAG100M7V1B				26.9	-	32	-	23.5	0.094+0.094	0.75+0.75	0.044x3	0.3x3
FCAG50AVEB	x2 RZAG100M7V1B				26.6	-	32	-	23.5	0.094+0.094	0.75+0.75	0.039x2	0.3x2
FCAG100AVEB	RZAG100M7V1B	26.7	-	32	-	23.5	0.094+0.094	0.75+0.75	0.117	0.7			
FFA35A2VEB	x3 RZAG100M7V1B	27.2	-	32	-	23.5	0.094+0.094	0.75+0.75	0.050x3	0.4x3			
FFA50A2VEB	x2 RZAG100M7V1B	26.8	-	32	-	23.5	0.094+0.094	0.75+0.75	0.050x2	0.4x2			
FBA35A2VEB	x3 RZAG100M7V1B	27.9	-	32	-	23.5	0.094+0.094	0.75+0.75	0.089x3	0.6x3			
FBA50A2VEB	x2 RZAG100M7V1B	27.2	-	32	-	23.5	0.094+0.094	0.75+0.75	0.089x2	0.6x2			
FBA100A2VEB	RZAG100M7V1B	27.0	-	32	-	23.5	0.094+0.094	0.75+0.75	0.127	1.0			
FNA35A2VEB	x3 RZAG100M7V1B	26.9	-	32	-	23.5	0.094+0.094	0.75+0.75	0.034x3	0.3x3			
FNA50A2VEB	x2 RZAG100M7V1B	27.0	-	32	-	23.5	0.094+0.094	0.75+0.75	0.060x2	0.5x2			
FUA100AVEB	RZAG100M7V1B	27.4	-	32	-	23.5	0.094+0.094	0.75+0.75	0.106	1.3			
FAA100AUVEB	RZAG100M7V1B	26.4	-	32	-	23.5	0.094+0.094	0.75+0.75	0.064	0.4			
FVA100AMVEB	RZAG100M7V1B	27.2	-	32	-	23.5	0.094+0.094	0.75+0.75	0.238	1.2			
FDXM35F3V1B	x3 RZAG100M7V1B	26.9	-	32	-	23.5	0.094+0.094	0.75+0.75	0.034x3	0.3x3			
FDXM50F3V1B	x2 RZAG100M7V1B	27.0	-	32	-	23.5	0.094+0.094	0.75+0.75	0.060x2	0.5x2			
FHA35AVEB	x3 RZAG100M7V1B	27.9	-	32	-	23.5	0.094+0.094	0.75+0.75	0.060x3	0.6x3			
FHA50AVEB	x2 RZAG100M7V1B	27.2	-	32	-	23.5	0.094+0.094	0.75+0.75	0.060x2	0.6x2			
FHA100AVEB	RZAG100M7V1B	27.4	-	32	-	23.5	0.094+0.094	0.75+0.75	0.150	1.3			

RZAG71-100MV1

3D110014A

RZAG125-140MV1

Indoor	Outdoor	Power supply	Voltage range	MCA	TOCA	MFA	Compressor		OFM		IFM		
							MSC	RLA	kW	FLA	kW	FLA	
FCAHG125GVEB	RZAG125M7V1B	50 Hz~ 220- 240V	Minimum: 198 V	Maximum: 264 V	27.5	-	32	-	23.5	0.094+0.094	0.75+0.75	0.244	1.4
FCAG35AVEB	x4 RZAG125M7V1B				27.2	-	32	-	23.5	0.094+0.094	0.75+0.75	0.044x4	0.3x4
FCAG50AVEB	x3 RZAG125M7V1B				26.9	-	32	-	23.5	0.094+0.094	0.75+0.75	0.039x3	0.3x3
FCAG60AVEB	x2 RZAG125M7V1B				26.6	-	32	-	23.5	0.094+0.094	0.75+0.75	0.044x2	0.3x2
FCAG125AVEB	RZAG125M7V1B				27.0	-	32	-	23.5	0.094+0.094	0.75+0.75	0.168	1.0
FFA35A2VEB	x4 RZAG125M7V1B				27.7	-	32	-	23.5	0.094+0.094	0.75+0.75	0.050x4	0.4x4
FFA50A2VEB	x3 RZAG125M7V1B				27.2	-	32	-	23.5	0.094+0.094	0.75+0.75	0.050x3	0.4x3
FFA60A2VEB	x2 RZAG125M7V1B				27.2	-	32	-	23.5	0.094+0.094	0.75+0.75	0.050x2	0.6x2
FBA35A2VEB	x4 RZAG125M7V1B				28.5	-	32	-	23.5	0.094+0.094	0.75+0.75	0.089x3	0.6x4
FBA50A2VEB	x3 RZAG125M7V1B				27.9	-	32	-	23.5	0.094+0.094	0.75+0.75	0.089x3	0.6x2
FBA60A2VEB	x2 RZAG125M7V1B				27.0	-	32	-	23.5	0.094+0.094	0.75+0.75	0.070x2	0.5x2
FBA125A2VEB	RZAG125M7V1B				27.6	-	32	-	23.5	0.094+0.094	0.75+0.75	0.187	1.5
FNA35A2VEB	x4 RZAG125M7V1B				27.2	-	32	-	23.5	0.094+0.094	0.75+0.75	0.034x4	0.3x4
FNA50A2VEB	x3 RZAG125M7V1B				27.6	-	32	-	23.5	0.094+0.094	0.75+0.75	0.060x3	0.5x3
FNA60A2VEB	x2 RZAG125M7V1B				27.0	-	32	-	23.5	0.094+0.094	0.75+0.75	0.060x2	0.5x2
FUA125AVEB	RZAG125M7V1B				27.5	-	32	-	23.5	0.094+0.094	0.75+0.75	0.106	1.4
FDA125AVEB	RZAG125M7V1B				28.2	-	32	-	23.5	0.094+0.094	0.75+0.75	0.350	2.1
FVA125AMVEB	RZAG125M7V1B				27.2	-	32	-	23.5	0.094+0.094	0.75+0.75	0.238	1.2
FDXM35F3V1B	x4 RZAG125M7V1B				27.2	-	32	-	23.5	0.094+0.094	0.75+0.75	0.034x4	0.3x4
FDXM50F3V1B	x3 RZAG125M7V1B				27.6	-	32	-	23.5	0.094+0.094	0.75+0.75	0.060x3	0.5x3
FDXM60F3V1B	x2 RZAG125M7V1B				27.0	-	32	-	23.5	0.094+0.094	0.75+0.75	0.060x2	0.5x2
FHA35AVEB	x4 RZAG125M7V1B				28.5	-	32	-	23.5	0.094+0.094	0.75+0.75	0.060x4	0.6x4
FHA50AVEB	x3 RZAG125M7V1B				27.9	-	32	-	23.5	0.094+0.094	0.75+0.75	0.060x3	0.6x3
FHA60AVEB	x2 RZAG125M7V1B				27.2	-	32	-	23.5	0.094+0.094	0.75+0.75	0.091x2	0.6x2
FHA125AVEB	RZAG125M7V1B	27.6	-	32	-	23.5	0.094+0.094	0.75+0.75	0.150	1.5			
FCAHG71GVEB	x2 RZAG145M7V1B	27.0	-	32	-	23.5	0.094+0.094	0.75+0.75	0.091x2	0.5x2			
FCAHG140GVEB	RZAG145M7V1B	27.5	-	32	-	23.5	0.094+0.094	0.75+0.75	0.244	1.4			
FCAG35AVEB	x4 RZAG145M7V1B	27.2	-	32	-	23.5	0.094+0.094	0.75+0.75	0.044x4	0.3x4			
FCAG50AVEB	x3 RZAG145M7V1B	26.9	-	32	-	23.5	0.094+0.094	0.75+0.75	0.039x3	0.3x3			
FCAG71AVEB	x2 RZAG145M7V1B	26.8	-	32	-	23.5	0.094+0.094	0.75+0.75	0.054x2	0.4x2			
FCAG140AVEB	RZAG145M7V1B	27.0	-	32	-	23.5	0.094+0.094	0.75+0.75	0.168	1.0			
FFA35A2VEB	x4 RZAG145M7V1B	27.7	-	32	-	23.5	0.094+0.094	0.75+0.75	0.050x4	0.4x4			
FFA50A2VEB	x3 RZAG145M7V1B	27.2	-	32	-	23.5	0.094+0.094	0.75+0.75	0.050x3	0.4x3			
FBA35A2VEB	x4 RZAG145M7V1B	28.5	-	32	-	23.5	0.094+0.094	0.75+0.75	0.089x4	0.6x4			
FBA50A2VEB	x3 RZAG145M7V1B	27.9	-	32	-	23.5	0.094+0.094	0.75+0.75	0.089x3	0.6x3			
FBA71A2VEB	x2 RZAG145M7V1B	27.0	-	32	-	23.5	0.094+0.094	0.75+0.75	0.070x2	0.5x2			
FBA140A2VEB	RZAG145M7V1B	27.6	-	32	-	23.5	0.094+0.094	0.75+0.75	0.187	1.5			
FNA35A2VEB	x4 RZAG145M7V1B	27.2	-	32	-	23.5	0.094+0.094	0.75+0.75	0.034x4	0.3x4			
FNA50A2VEB	x3 RZAG145M7V1B	27.6	-	32	-	23.5	0.094+0.094	0.75+0.75	0.060x3	0.5x3			
FUA71AVEB	x2 RZAG145M7V1B	27.9	-	32	-	23.5	0.094+0.094	0.75+0.75	0.046x2	0.9x2			
FAA71AUVEB	x2 RZAG145M7V1B	26.8	-	32	-	23.5	0.094+0.094	0.75+0.75	0.048x2	0.4x2			
FVA71AMVEB	x2 RZAG145M7V1B	27.2	-	32	-	23.5	0.094+0.094	0.75+0.75	0.117x2	0.6x2			
FVA140AMVEB	RZAG145M7V1B	27.5	-	32	-	23.5	0.094+0.094	0.75+0.75	0.276	1.4			
FDXM35F3V1B	x4 RZAG145M7V1B	27.2	-	32	-	23.5	0.094+0.094	0.75+0.75	0.034x4	0.3x4			
FDXM50F3V1B	x3 RZAG145M7V1B	27.6	-	32	-	23.5	0.094+0.094	0.75+0.75	0.060x3	0.5x3			
FHA35AVEB	x4 RZAG145M7V1B	28.5	-	32	-	23.5	0.094+0.094	0.75+0.75	0.060x4	0.6x4			
FHA50AVEB	x3 RZAG145M7V1B	27.9	-	32	-	23.5	0.094+0.094	0.75+0.75	0.060x3	0.6x3			
FHA71AVEB	x2 RZAG145M7V1B	27.7	-	32	-	23.5	0.094+0.094	0.75+0.75	0.091x2	0.8x2			
FHA140AVEB	RZAG145M7V1B	27.9	-	32	-	23.5	0.094+0.094	0.75+0.75	0.150	1.8			

RZAG125-140MV1

3D110014A.



RZAG71-100MY1 COMFORT COOLING

Indoor	Outdoor	Power supply	Voltage range	MCA	TOCA	MFA	Compressor		OFM		IFM					
							MSC	RLA	kW	FLA	kW	FLA				
FCAHG71GVEB	RZAG71M7Y1B	3 N~ 50Hz 380- 415 V	Minimum: 342 V	Maximum: 456 V	10.9	-	16	-	9.2	0.094	0.8	0.091	0.5			
FCAG35AVEB	x2 RZAG71M7Y1B				11.0	-	16	-	9.2	0.094	0.8	0.044x2	0.3x2			
FCAG71AVEB	RZAG71M7Y1B				10.8	-	16	-	9.2	0.094	0.8	0.054	0.4			
FFA35A2VEB	x2 RZAG71M7Y1B				11.2	-	16	-	9.2	0.094	0.8	0.050x2	0.4x2			
FBA35A2VEB	x2 RZAG71M7Y1B				11.6	-	16	-	9.2	0.094	0.8	0.089x2	0.6x2			
FBA71A2VEB	RZAG71M7Y1B				10.9	-	16	-	9.2	0.094	0.8	0.070	0.5			
FNA35A2VEB	x2 RZAG71M7Y1B				10.7	-	16	-	9.2	0.094	0.8	0.034x2	0.3			
FUA71AVEB	RZAG71M7Y1B				11.3	-	16	-	9.2	0.094	0.8	0.046	0.9			
FAA71AUVEB	RZAG71M7Y1B				10.8	-	16	-	9.2	0.094	0.8	0.048	0.4			
FVA71AMVEB	RZAG71M7Y1B				11.0	-	16	-	9.2	0.094	0.8	0.117	0.6			
FDXM35F3V1B	x2 RZAG71M7Y1B				11.0	-	16	-	9.2	0.094	0.8	0.034x2	0.3x2			
FHA35AVEB	x2 RZAG71M7Y1B				11.6	-	16	-	9.2	0.094	0.8	0.060x2	0.6x2			
FHA71AVEB	RZAG71M7Y1B				11.2	-	16	-	9.2	0.094	0.8	0.091	0.8			
FCAHG100GVEB	RZAG100M7Y1B				3 N~ 50Hz 380- 415 V	Minimum: 342 V	Maximum: 456 V	15.4	-	16	-	12.0	0.094+0.094	0.75+0.75	0.221	1.3
FCAG35AVEB	x3 RZAG100M7Y1B							12.9	-	16	-	10.0	0.094+0.094	0.75+0.75	0.044x3	0.3x3
FCAG50AVEB	x2 RZAG100M7Y1B							13.6	-	16	-	11.0	0.094+0.094	0.75+0.75	0.039x2	0.3x2
FCAG100AVEB	RZAG100M7Y1B							14.8	-	16	-	12.0	0.094+0.094	0.75+0.75	0.117	0.7
FFA35A2VEB	x3 RZAG100M7Y1B							13.2	-	16	-	10.0	0.094+0.094	0.75+0.75	0.050x3	0.4x3
FFA50A2VEB	x2 RZAG100M7Y1B	13.8	-	16				-	11.0	0.094+0.094	0.75+0.75	0.050x2	0.4x2			
FBA35A2VEB	x3 RZAG100M7Y1B	13.8	-	16				-	10.0	0.094+0.094	0.75+0.75	0.089x3	0.6x3			
FBA50A2VEB	x2 RZAG100M7Y1B	14.2	-	16				-	11.0	0.094+0.094	0.75+0.75	0.089x2	0.6x2			
FBA100A2VEB	RZAG100M7Y1B	15.1	-	16				-	12.0	0.094+0.094	0.75+0.75	0.127	1.0			
FNA35A2VEB	x3 RZAG100M7Y1B	12.9	-	16				-	10.0	0.094+0.094	0.75+0.75	0.034x3	0.3x3			
FNA50A2VEB	x2 RZAG100M7Y1B	14.0	-	16				-	11.0	0.094+0.094	0.75+0.75	0.060x2	0.5x2			
FUA100AVEB	RZAG100M7Y1B	15.4	-	16				-	12.0	0.094+0.094	0.75+0.75	0.106	1.3			
FAA100AUVEB	RZAG100M7Y1B	14.5	-	16				-	12.0	0.094+0.094	0.75+0.75	0.064	0.4			
FVA100AMVEB	RZAG100M7Y1B	15.3	-	16				-	12.0	0.094+0.094	0.75+0.75	0.238	1.2			
FDXM35F3V1B	x3 RZAG100M7Y1B	12.9	-	16				-	10.0	0.094+0.094	0.75+0.75	0.034	0.3x3			
FDXM50F3V1B	x2 RZAG100M7Y1B	14.0	-	16				-	11.0	0.094+0.094	0.75+0.75	0.060x2	0.5x2			
FHA35AVEB	x3 RZAG100M7Y1B	13.8	-	16				-	10.0	0.094+0.094	0.75+0.75	0.060x3	0.6x3			
FHA50AVEB	x2 RZAG100M7Y1B	14.2	-	16				-	11.0	0.094+0.094	0.75+0.75	0.060x2	0.6x2			
FHA100AVEB	RZAG100M7Y1B	15.4	-	16	-	12.0	0.094+0.094	0.75+0.75	0.150	1.3						

RZAG71- 100MY1

3D110014A

RZAG125-140MY1

Indoor	Outdoor	Power supply	Voltage range	MCA	TOCA	MFA	Compressor		OFM		IFM					
							MSC	RLA	kW	FLA	kW	FLA				
FCAHG125GVEB	RZAG125M7Y1B	3 N~50Hz 380- 415 V	Minimum: 342 V	Maximum: 456 V	15.0	-	16	-	11.5	0.094+0.094	0.75+0.75	0.244	1.4			
FCAG35AVEB	x4 RZAG125M7Y1B				12.2	-	16	-	9.0	0.094+0.094	0.75+0.75	0.044x4	0.3x4			
FCAG50AVEB	x3 RZAG125M7Y1B				12.9	-	16	-	10.0	0.094+0.094	0.75+0.75	0.039x3	0.3x3			
FCAG60AVEB	x2 RZAG125M7Y1B				14.1	-	16	-	11.5	0.094+0.094	0.75+0.75	0.044x2	0.3x2			
FCAG125AVEB	RZAG125M7Y1B				14.6	-	16	-	11.5	0.094+0.094	0.75+0.75	0.168	1.0			
FFA35A2VEB	x4 RZAG125M7Y1B				12.6	-	16	-	9.0	0.094+0.094	0.75+0.75	0.050x4	0.4x4			
FFA50A2VEB	x3 RZAG125M7Y1B				13.2	-	16	-	10.0	0.094+0.094	0.75+0.75	0.050x3	0.4x3			
FFA60A2VEB	x2 RZAG125M7Y1B				14.8	-	16	-	11.5	0.094+0.094	0.75+0.75	0.050x2	0.6x2			
FBA35A2VEB	x4 RZAG125M7Y1B				13.4	-	16	-	9.0	0.094+0.094	0.75+0.75	0.089x4	0.6x4			
FBA50A2VEB	x3 RZAG125M7Y1B				13.8	-	16	-	10.0	0.094+0.094	0.75+0.75	0.089x3	0.6x3			
FBA60A2VEB	x2 RZAG125M7Y1B				14.6	-	16	-	11.5	0.094+0.094	0.75+0.75	0.070x2	0.5x2			
FBA125A2VEB	RZAG125M7Y1B				15.1	-	16	-	11.5	0.094+0.094	0.75+0.75	0.187	1.5			
FBA35A2VEB	x4 RZAG125M7Y1B				12.2	-	16	-	9.0	0.094+0.094	0.75+0.75	0.034x4	0.3x4			
FNA50A2VEB	x3 RZAG125M7Y1B				13.5	-	16	-	10.0	0.094+0.094	0.75+0.75	0.060x3	0.5x3			
FNA60A2VEB	x2 RZAG125M7Y1B				14.6	-	16	-	11.5	0.094+0.094	0.75+0.75	0.060x2	0.5x2			
FUA125AVEB	RZAG125M7Y1B				15.0	-	16	-	11.5	0.094+0.094	0.75+0.75	0.106	1.4			
FDA125A5VEB	RZAG125M7Y1B				15.7	-	16	-	11.5	0.094+0.094	0.75+0.75	0.350	2.1			
FVA125A5VEB	RZAG125M7Y1B				14.8	-	16	-	11.5	0.094+0.094	0.75+0.75	0.238	1.2			
FDXM35F3V1B	x4 RZAG125M7Y1B				12.2	-	16	-	9.0	0.094+0.094	0.75+0.75	0.034x4	0.3x4			
FDXM50F3V1B	x3 RZAG125M7Y1B				13.5	-	16	-	10.0	0.094+0.094	0.75+0.75	0.060x3	0.5x3			
FDXM60F3V1B	x2 RZAG125M7Y1B				14.6	-	16	-	11.5	0.094+0.094	0.75+0.75	0.060x2	0.5x2			
FHA35AVEB	x4 RZAG125M7Y1B				13.4	-	16	-	9.0	0.094+0.094	0.75+0.75	0.060x4	0.6x4			
FHA50AVEB	x3 RZAG125M7Y1B				13.8	-	16	-	10.0	0.094+0.094	0.75+0.75	0.060x3	0.6x3			
FHA60AVEB	x2 RZAG125M7Y1B				14.8	-	16	-	11.5	0.094+0.094	0.75+0.75	0.091x2	0.6x2			
FHA125AVEB	RZAG125M7Y1B				15.1	-	16	-	11.5	0.094+0.094	0.75+0.75	0.150	1.5			
FCAH71GVEB	x2 RZAG140M7Y1B				3 N~50Hz 380- 415 V	Minimum: 342 V	Maximum: 456 V	14.6	-	16	-	11.5	0.094+0.094	0.75+0.75	0.091x2	0.5x2
FCAHG140GVEB	RZAG140M7Y1B							15.0	-	16	-	11.5	0.094+0.094	0.75+0.75	0.244	1.4
FCAG35AVEB	x4 RZAG140M7Y1B							12.2	-	16	-	9.0	0.094+0.094	0.75+0.75	0.044x4	0.3x4
FCAG50AVEB	x3 RZAG140M7Y1B							12.9	-	16	-	10.0	0.094+0.094	0.75+0.75	0.039x3	0.3x3
FCAG71AVEB	x2 RZAG140M7Y1B							14.4	-	16	-	11.5	0.094+0.094	0.75+0.75	0.054x2	0.4x2
FCAG140AVEB	RZAG140M7Y1B	14.6	-	16				-	11.5	0.094+0.094	0.75+0.75	0.168	1.0			
FFA35A2VEB	x4 RZAG140M7Y1B	12.6	-	16				-	9.0	0.094+0.094	0.75+0.75	0.050x4	0.4x4			
FFA50A2VEB	x3 RZAG140M7Y1B	13.2	-	16				-	10.0	0.094+0.094	0.75+0.75	0.050x3	0.4x3			
FBA35A2VEB	x4 RZAG140M7Y1B	13.4	-	16				-	9.0	0.094+0.094	0.75+0.75	0.089x4	0.6x4			
FBA50A2VEB	x3 RZAG140M7Y1B	13.8	-	16				-	10.0	0.094+0.094	0.75+0.75	0.089x3	0.6x3			
FBA71A2VEB	x2 RZAG140M7Y1B	14.6	-	16				-	11.5	0.094+0.094	0.75+0.75	0.070x2	0.5x2			
FBA140A2VEB	RZAG140M7Y1B	15.1	-	16				-	11.5	0.094+0.094	0.75+0.75	0.187	1.5			
FNA35A2VEB	x4 RZAG140M7Y1B	12.2	-	16				-	9.0	0.094+0.094	0.75+0.75	0.034x4	0.3x4			
FNA50A2VEB	x3 RZAG140M7Y1B	13.5	-	16				-	10.0	0.094+0.094	0.75+0.75	0.060x3	0.5x3			
FUA71AVEB	x2 RZAG140M7Y1B	15.4	-	16				-	11.5	0.094+0.094	0.75+0.75	0.046x2	0.9x2			
FAA71AUVEB	x2 RZAG140M7Y1B	14.4	-	16				-	11.5	0.094+0.094	0.75+0.75	0.048x2	0.4x2			
FVA71AMVEB	x2 RZAG140M7Y1B	14.8	-	16				-	11.5	0.094+0.094	0.75+0.75	0.117x2	0.6x2			
FVA140AMVEB	RZAG140M7Y1B	15.0	-	16				-	11.5	0.094+0.094	0.75+0.75	0.276	1.4			
FDXM35F3V1B	x4 RZAG140M7Y1B	12.2	-	16				-	9.0	0.094+0.094	0.75+0.75	0.034x4	0.3x4			
FDXM50F3V1B	x3 RZAG140M7Y1B	13.5	-	16				-	10.0	0.094+0.094	0.75+0.75	0.060x3	0.5x3			
FHA35AVEB	x4 RZAG140M7Y1B	13.4	-	16				-	9.0	0.094+0.094	0.75+0.75	0.060x4	0.6x4			
FHA50AVEB	x3 RZAG140M7Y1B	13.8	-	16				-	10.0	0.094+0.094	0.75+0.75	0.060x3	0.6x3			
FHA71AVEB	x2 RZAG140M7Y1B	15.2	-	16				-	11.5	0.094+0.094	0.75+0.75	0.091x2	0.8x2			
FHA140AVEB	RZAG140M7Y1B	15.4	-	16				-	11.5	0.094+0.094	0.75+0.75	0.150	1.8			

RZAG125-140MY1

3D110014A.



RZAG-MV1/MY1

Symbols	Notes
MCA Min. Circuit Amps. (A)	1 RLA is based on the following indoor conditions: Cooling Indoor temperature 27.0°CDB/19.0°CWB Outdoor temperature 35.0°CDB Heating Indoor temperature 20.0°CDB Outdoor temperature 7.0°CDB/6.0°CWB. 2 TOCA means the total value of each OC set. 3 Voltage range Units are suitable for use on electrical systems where voltage supplied to unit terminals is not below or above listed range limits. 4 Maximum allowable voltage variation between phases is 2% . 5 MCA is the maximum input current. The capacity of the MFA must be greater than that of the MCA. Select the MFA according to the table. 6 Select the wire size according to the MCA. 7 MFA is used to select the circuit breaker and the ground fault circuit interrupter. (earth leakage circuit breaker)
TOCA Total Over-Current Amps. (A)	
MFA Max. Fuse Amps (See note 7) (A)	
MSC Max. current during the starting compressor. (A)	
RLA Rated Load Amps. (A)	
OFM Outdoor Fan Motor. (A)	
IFM Indoor Fan Motor.	
FLA Full Load Amps.	
kW Fan Motor Rated Output (kW)	

3D110014A.

RZAG71-100MV1 INFRASTRUCTURE COOLING

Indoor	Outdoor	Power supply	Voltage range	MCA	TOCA	MFA	Compressor		OFM		IFM			
							MSC	RLA	kW	FLA	kW	FLA		
FCAHG100GVBE	RZAG71M7V1B	50Hz~ 220- 240 V	Minimum: 198 V Maximum: 264 V	18.3	-	20	-	15.5	0.094	0.8	0.221	1.3		
FCAG35AVEB	x3 RZAG71M7V1B			17.9	-	20	-	15.5	0.094	0.8	0.044x3	0.3x3		
FCAG50AVEB	x2 RZAG71M7V1B			17.6	-	20	-	15.5	0.094	0.8	0.039x2	0.3x2		
FCAG100AVEB	RZAG71M7V1B			17.7	-	20	-	15.5	0.094	0.8	0.117	0.7		
FFA35A2VEB	x3 RZAG71M7V1B			18.2	-	20	-	15.5	0.094	0.8	0.050x3	0.4x3		
FFA50A2VEB	x2 RZAG71M7V1B			17.8	-	20	-	15.5	0.094	0.8	0.050x2	0.4x2		
FBA35A2VEB	x3 RZAG71M7V1B			18.8	-	20	-	15.5	0.094	0.8	0.089x3	0.6x3		
FBA50A2VEB	x2 RZAG71M7V1B			18.2	-	20	-	15.5	0.094	0.8	0.089x2	0.6x2		
FBA100A2VEB	RZAG71M7V1B			18.0	-	20	-	15.5	0.094	0.8	0.127	1.0		
FUA100AVEB	RZAG71M7V1B			18.3	-	20	-	15.5	0.094	0.8	0.106	1.3		
FAA100AUVEB	RZAG71M7V1B			17.4	-	20	-	15.5	0.094	0.8	0.064	0.4		
FVA100AMVEB	RZAG71M7V1B			18.2	-	20	-	15.5	0.094	0.8	0.238	1.2		
FDXM35F3V1B	x3 RZAG71M7V1B			17.9	-	20	-	15.5	0.094	0.8	0.034x3	0.3x3		
FDXM50F3V1B	x2 RZAG71M7V1B			18.0	-	20	-	15.5	0.094	0.8	0.060x2	0.5x2		
FHA35AVEB	x3 RZAG71M7V1B			18.8	-	20	-	15.5	0.094	0.8	0.060x3	0.6x3		
FHA50AVEB	x2 RZAG71M7V1B			18.2	-	20	-	15.5	0.094	0.8	0.060x2	0.6x2		
FHA100AVEB	RZAG71M7V1B			18.3	-	20	-	15.5	0.094	0.8	0.150	1.3		
FCAHG71GVBE	x2 RZAG100M7V1B			50Hz~ 220- 240 V	Minimum: 198 V Maximum: 264 V	27.0	-	32	-	23.5	0.094+ 0.094	0.75+ 0.75	0.091x2	0.5x2
FCAHG140GVBE	RZAG100M7V1B					27.5	-	32	-	23.5	0.094+ 0.094	0.75+ 0.75	0.244	1.4
FCAG35AVEB	x4 RZAG100M7V1B					27.2	-	32	-	23.5	0.094+ 0.094	0.75+ 0.75	0.044x4	0.3x4
FCAG50AVEB	x3 RZAG100M7V1B	26.9	-			32	-	23.5	0.094+ 0.094	0.75+ 0.75	0.039x3	0.3x3		
FCAG71AVEB	x2 RZAG100M7V1B	26.8	-			32	-	23.5	0.094+ 0.094	0.75+ 0.75	0.054x2	0.4x2		
FCAG140AVEB	RZAG100M7V1B	27.0	-			32	-	23.5	0.094+ 0.094	0.75+ 0.75	0.168	1.0		
FFA35A2VEB	x4 RZAG100M7V1B	27.7	-			32	-	23.5	0.094+ 0.094	0.75+ 0.75	0.050x4	0.4x4		
FFA50A2VEB	x3 RZAG100M7V1B	27.2	-			32	-	23.5	0.094+ 0.094	0.75+ 0.75	0.050x3	0.4x3		
FBA35A2VEB	x4 RZAG100M7V1B	28.5	-			32	-	23.5	0.094+ 0.094	0.75+ 0.75	0.089x4	0.6x4		
FBA50A2VEB	x3 RZAG100M7V1B	27.9	-			32	-	23.5	0.094+ 0.094	0.75+ 0.75	0.089x3	0.6x3		
FBA71A2VEB	x2 RZAG100M7V1B	27.0	-			32	-	23.5	0.094+ 0.094	0.75+ 0.75	0.07x2	0.5x2		
FBA140A2VEB	RZAG100M7V1B	27.6	-			32	-	23.5	0.094+ 0.094	0.75+ 0.75	0.187	1.5		
FUA71AVEB	x2 RZAG100M7V1B	27.9	-			32	-	23.5	0.094+ 0.094	0.75+ 0.75	0.046x2	0.9x2		
FAA71AUVEB	x2 RZAG100M7V1B	26.8	-			32	-	23.5	0.094+ 0.094	0.75+ 0.75	0.048x2	0.4x2		
FVA140AMVEB	RZAG100M7V1B	27.5	-			32	-	23.5	0.094+ 0.094	0.75+ 0.75	0.276	1.4		
FDXM35F3V1B	x4 RZAG100M7V1B	27.2	-			32	-	23.5	0.094+ 0.094	0.75+ 0.75	0.034x4	0.3x4		
FDXM50F3V1B	x3 RZAG100M7V1B	27.6	-			32	-	23.5	0.094+ 0.094	0.75+ 0.75	0.060x3	0.5x3		
FHA35AVEB	x4 RZAG100M7V1B	28.5	-			32	-	23.5	0.094+ 0.094	0.75+ 0.75	0.060x4	0.6x4		
FHA50AVEB	x3 RZAG100M7V1B	27.9	-			32	-	23.5	0.094+ 0.094	0.75+ 0.75	0.060x3	0.6x3		
FHA71AVEB	x2 RZAG100M7V1B	27.7	-			32	-	23.5	0.094+ 0.094	0.75+ 0.75	0.091x2	0.8x2		
fHA140AVEB	RZAG100M7V1B	27.9	-	32	-	23.5	0.094+ 0.094	0.75+ 0.75	0.150	1.8				

RZAG71-100MV1

3D110015A



RZAG125-140MV1 INFRASTRUCTURE COOLING

Indoor	Outdoor	Power supply	Voltage range	MCA	TOCA	MFA	Compressor		OFM		IFM					
							MSC	RLA	kW	FLA	kW	FLA				
FCAHG71GVEB	x2 RZAG125M7V1B	50Hz ~ 220-240 V	Minimum: 198 V	Maximum: 264 V	27.0	-	32	-	23.5	0.094+0.094	0.75+0.75	0.091x2	0.5x2			
FCAHG140GVEB	RZAG125M7V1B				27.5	-	32	-	23.5	0.094+0.094	0.75+0.75	0.244	1.4			
FCAG35AVEB	x4 RZAG125M7V1B				27.2	-	32	-	23.5	0.094+0.094	0.75+0.75	0.044x4	0.3x4			
FCAG50AVEB	x3 RZAG125M7V1B				26.9	-	32	-	23.5	0.094+0.094	0.75+0.75	0.039x3	0.3x3			
FCAG71AVEB	x2 RZAG125M7V1B				26.8	-	32	-	23.5	0.094+0.094	0.75+0.75	0.054x2	0.4x2			
FCAG140AVEB	RZAG125M7V1B				27.0	-	32	-	23.5	0.094+0.094	0.75+0.75	0.168	1.0			
FFA35A2VEB	x4 RZAG125M7V1B				27.7	-	32	-	23.5	0.094+0.094	0.75+0.75	0.050x4	0.4x4			
FFA50A2VEB	x3 RZAG125M7V1B				27.2	-	32	-	23.5	0.094+0.094	0.75+0.75	0.050x3	0.4x3			
FBA35A2VEB	x4 RZAG125M7V1B				28.5	-	32	-	23.5	0.094+0.094	0.75+0.75	0.089x4	0.6x4			
FBA50A2VEB	x3 RZAG125M7V1B				27.9	-	32	-	23.5	0.094+0.094	0.75+0.75	0.089x3	0.6x3			
FBA71A2VEB	x2 RZAG125M7V1B				27.0	-	32	-	23.5	0.094+0.094	0.75+0.75	0.07x2	0.5x2			
FBA140A2VEB	RZAG125M7V1B				27.6	-	32	-	23.5	0.094+0.094	0.75+0.75	0.187	1.5			
FUA71AVEB	x2 RZAG125M7V1B				27.9	-	32	-	23.5	0.094+0.094	0.75+0.75	0.046x2	0.9x2			
FAA71AUVEB	x2 RZAG125M7V1B				26.8	-	32	-	23.5	0.094+0.094	0.75+0.75	0.048x2	0.4x2			
FVA140AMVEB	RZAG125M7V1B				27.5	-	32	-	23.5	0.094+0.094	0.75+0.75	0.276	1.4			
FDXM35F3V1B	x4 RZAG125M7V1B				27.2	-	32	-	23.5	0.094+0.094	0.75+0.75	0.034x4	0.3x4			
FDXM50F3V1B	x3 RZAG125M7V1B				27.6	-	32	-	23.5	0.094+0.094	0.75+0.75	0.060x3	0.5x3			
FHA35AVEB	x4 RZAG125M7V1B				28.5	-	32	-	23.5	0.094+0.094	0.75+0.75	0.060x4	0.6x4			
FHA50AVEB	x3 RZAG125M7V1B				27.9	-	32	-	23.5	0.094+0.094	0.75+0.75	0.060x3	0.6x3			
FHA71AVEB	x2 RZAG125M7V1B				27.7	-	32	-	23.5	0.094+0.094	0.75+0.75	0.091x2	0.8x2			
FHA140AVEB	RZAG125M7V1B				27.9	-	32	-	23.5	0.094+0.094	0.75+0.75	0.150	1.8			
FCAHG71GVEB	x2 RZAG140M7V1B				50Hz ~ 220-240 V	Minimum: 198 V	Maximum: 264 V	27.0	-	32	-	23.5	0.094+0.094	0.75+0.75	0.091x2	0.5x2
FCAHG140GVEB	RZAG140M7V1B							27.5	-	32	-	23.5	0.094+0.094	0.75+0.75	0.244	1.4
FCAG35AVEB	x4 RZAG140M7V1B							27.2	-	32	-	23.5	0.094+0.094	0.75+0.75	0.044x4	0.3x4
FCAG50AVEB	x3 RZAG140M7V1B							26.9	-	32	-	23.5	0.094+0.094	0.75+0.75	0.039x3	0.3x3
FCAG71AVEB	x2 RZAG140M7V1B							26.8	-	32	-	23.5	0.094+0.094	0.75+0.75	0.054x2	0.4x2
FCAG140AVEB	RZAG140M7V1B							27.0	-	32	-	23.5	0.094+0.094	0.75+0.75	0.168	1.0
FFA35A2VEB	x4 RZAG140M7V1B							27.7	-	32	-	23.5	0.094+0.094	0.75+0.75	0.050x4	0.4x4
FFA50A2VEB	x3 RZAG140M7V1B	27.2	-	32				-	23.5	0.094+0.094	0.75+0.75	0.050x3	0.4x3			
FBA35A2VEB	x4 RZAG140M7V1B	28.5	-	32				-	23.5	0.094+0.094	0.75+0.75	0.089x4	0.6x4			
FBA50A2VEB	x3 RZAG140M7V1B	27.9	-	32				-	23.5	0.094+0.094	0.75+0.75	0.089x3	0.6x3			
FBA71A2VEB	x2 RZAG140M7V1B	27.0	-	32				-	23.5	0.094+0.094	0.75+0.75	0.07x2	0.5x2			
FBA140A2VEB	RZAG140M7V1B	27.6	-	32				-	23.5	0.094+0.094	0.75+0.75	0.187	1.5			
FUA71AVEB	x2 RZAG140M7V1B	27.9	-	32				-	23.5	0.094+0.094	0.75+0.75	0.046x2	0.9x2			
FAA71AUVEB	x2 RZAG140M7V1B	26.8	-	32				-	23.5	0.094+0.094	0.75+0.75	0.048x2	0.4x2			
FVA140AMVEB	RZAG140M7V1B	27.5	-	32				-	23.5	0.094+0.094	0.75+0.75	0.276	1.4			
FDXM35F3V1B	x4 RZAG140M7V1B	27.2	-	32				-	23.5	0.094+0.094	0.75+0.75	0.034x4	0.3x4			
FDXM50F3V1B	x3 RZAG140M7V1B	27.6	-	32				-	23.5	0.094+0.094	0.75+0.75	0.060x3	0.5x3			
FHA35AVEB	x4 RZAG140M7V1B	28.5	-	32				-	23.5	0.094+0.094	0.75+0.75	0.060x4	0.6x4			
FHA50AVEB	x3 RZAG140M7V1B	27.9	-	32				-	23.5	0.094+0.094	0.75+0.75	0.060x3	0.6x3			
FHA71AVEB	x2 RZAG140M7V1B	27.7	-	32				-	23.5	0.094+0.094	0.75+0.75	0.091x2	0.8x2			
FHA140AVEB	RZAG140M7V1B	27.9	-	32				-	23.5	0.094+0.094	0.75+0.75	0.150	1.8			

RZAG125-140MV1

3D110015A

RZAG71-100MY1

Indoor	Outdoor	Power supply	Voltage range	MCA	TOCA	MFA	Compressor		OFM		IFM					
							MSC	RLA	kW	FLA	kW	FLA				
FCAHG100GVEB	RZAG71M7Y1B	3n~ 50Hz 380-415 V	Minimum: 342 V	Maximum: 456 V	11.8	-	16	-	9.2	0.094	0.8	0.221	1.3			
FCAG35AVEB	x3 RZAG71M7Y1B				11.3	-	16	-	9.2	0.094	0.8	0.044x3	0.3x3			
FCAG50AVEB	x2 RZAG71M7Y1B				11.0	-	16	-	9.2	0.094	0.8	0.039x2	0.3x2			
FCAG100AVEB	RZAG71M7Y1B				11.1	-	16	-	9.2	0.094	0.8	0.117	0.7			
FFA35A2VEB	x3 RZAG71M7Y1B				11.6	-	16	-	9.2	0.094	0.8	0.050x3	0.4x3			
FFA50A2VEB	x2 RZAG71M7Y1B				11.2	-	16	-	9.2	0.094	0.8	0.050x2	0.4x2			
FBA35A2VEB	x3 RZAG71M7Y1B				12.3	-	16	-	9.2	0.094	0.8	0.089x3	0.6x3			
FBA50A2VEB	x2 RZAG71M7Y1B				11.6	-	16	-	9.2	0.094	0.8	0.089x2	0.6x2			
FBA100A2VEB	RZAG71M7Y1B				11.4	-	16	-	9.2	0.094	0.8	0.127	1.0			
FUA100AVEB	RZAG71M7Y1B				11.8	-	16	-	9.2	0.094	0.8	0.106	1.3			
FAA100AUVEB	RZAG71M7Y1B				10.8	-	16	-	9.2	0.094	0.8	0.064	0.4			
FVA100AMVEB	RZAG71M7Y1B				11.6	-	16	-	9.2	0.094	0.8	0.238	1.2			
FDXM35F3V1B	x3 RZAG71M7Y1B				11.3	-	16	-	9.2	0.094	0.8	0.034x3	0.3x3			
FDXM50F3V1B	x2 RZAG71M7Y1B				11.4	-	16	-	9.2	0.094	0.8	0.060x2	0.5x2			
FHA35AVEB	x3 RZAG71M7Y1B				12.3	-	16	-	9.2	0.094	0.8	0.060x3	0.6x3			
FHA50AVEB	x2 RZAG71M7Y1B				11.6	-	16	-	9.2	0.094	0.8	0.060x2	0.6x2			
FHA100AVEB	RZAG71M7Y1B				11.8	-	16	-	9.2	0.094	0.8	0.150	1.3			
FCAHG71GVEB	x2 RZAG100M7Y1B				3n~ 50Hz 380-415 V	Minimum: 342 V	Maximum: 456 V	14.0	-	16	-	11.0	0.094+ 0.094	0.75+0.75	0.091x2	0.5x2
FCAHG140GVEB	RZAG100M7Y1B							15.5	-	16	-	12.0	0.094+ 0.094	0.75+0.75	0.244	1.4
FCAG35AVEB	x4 RZAG100M7Y1B							13.2	-	16	-	10.0	0.094+ 0.094	0.75+0.75	0.044x4	0.3x4
FCAG50AVEB	x3 RZAG100M7Y1B							12.9	-	16	-	10.0	0.094+ 0.094	0.75+0.75	0.039x3	0.3x3
FCAG71AVEB	x2 RZAG100M7Y1B							13.8	-	16	-	11.0	0.094+ 0.094	0.75+0.75	0.054x2	0.4x2
FCAG140AVEB	RZAG100M7Y1B							15.1	-	16	-	12.0	0.094+ 0.094	0.75+0.75	0.168	1.0
FFA35A2VEB	x4 RZAG100M7Y1B							13.6	-	16	-	10.0	0.094+ 0.094	0.75+0.75	0.050x4	0.4x4
FFA50A2VEB	x3 RZAG100M7Y1B							13.2	-	16	-	10.0	0.094+ 0.094	0.75+0.75	0.050x3	0.4x3
FBA35A2VEB	x4 RZAG100M7Y1B							14.5	-	16	-	10.0	0.094+ 0.094	0.75+0.75	0.089x4	0.6x4
FBA50A2VEB	x3 RZAG100M7Y1B							13.8	-	16	-	10.0	0.094+ 0.094	0.75+0.75	0.089x3	0.6x3
FBA71A2VEB	x2 RZAG100M7Y1B							14.0	-	16	-	11.0	0.094+ 0.094	0.75+0.75	0.07x2	0.5x2
FBA140A2VEB	RZAG100M7Y1B	15.6	-	16				-	12.0	0.094+ 0.094	0.75+0.75	0.187	1.5			
FUA71AVEB	x2 RZAG100M7Y1B	14.9	-	16				-	11.0	0.094+ 0.094	0.75+0.75	0.046x2	0.9x2			
FAA71AUVEB	x2 RZAG100M7Y1B	13.8	-	16				-	11.0	0.094+ 0.094	0.75+0.75	0.048x2	0.4x2			
FVA140AMVEB	RZAG100M7Y1B	15.5	-	16				-	12.0	0.094+ 0.094	0.75+0.75	0.276	1.4			
FDXM35F3V1B	x4 RZAG100M7Y1B	13.2	-	16				-	10.0	0.094+ 0.094	0.75+0.75	0.034x4	0.3x4			
FDXM50F3V1B	x3 RZAG100M7Y1B	13.5	-	16				-	10.0	0.094+ 0.094	0.75+0.75	0.060x3	0.5x2			
FHA35AVEB	x4 RZAG100M7Y1B	14.5	-	16				-	10.0	0.094+ 0.094	0.75+0.75	0.060x4	0.6x4			
FHA50AVEB	x3 RZAG100M7Y1B	13.8	-	16				-	10.0	0.094+ 0.094	0.75+0.75	0.060x3	0.6x3			
FHA71AVEB	x2 RZAG100M7Y1B	14.7	-	16				-	11.0	0.094+ 0.094	0.75+0.75	0.091x2	0.8x2			
FHA140AVEB	RZAG100M7Y1B	15.9	-	16				-	12.0	0.094+ 0.094	0.75+0.75	0.150	1.8			

RZAG71-100MY1

3D110015A



RZAG125-140MY1 INFRASTRUCTURE COOLING

Indoor	Outdoor	Power supply	Voltage range	MCA	TOCA	MFA	Compresso		OFM		IFM					
							MSC	RLA	kW	FLA	kW	FLA				
FCAHG71GVEB	x2 RZAG125M7Y1B	3N~50Hz 380-415V	Minimum: 342 V	Maximum: 456 V	14.6	-	16	-	11.5	0.0904+ 0.0904	0.75+0.75	0.91x2	0.5x2			
FCAHG140GVEB	RZAG125M7Y1B				15.0	-	16	-	11.5	0.0904+ 0.0904	0.75+0.75	0.244	1.4			
FCAG35AVEB	x4 RZAG125M7Y1B				12.2	-	16	-	9.0	0.0904+ 0.0904	0.75+0.75	0.044x4	0.3x4			
FCAG50AVEB	x3 RZAG125M7Y1B				12.9	-	16	-	10.0	0.0904+ 0.0904	0.75+0.75	0.039x3	0.3x3			
FCAG71AVEB	x2 RZAG125M7Y1B				14.4	-	16	-	11.5	0.0904+ 0.0904	0.75+0.75	0.054x2	0.4x4			
FCAG140AVEB	RZAG125M7Y1B				14.6	-	16	-	11.5	0.0904+ 0.0904	0.75+0.75	0.168	1.0			
FFA35A2VEB	x4 RZAG125M7Y1B				12.6	-	16	-	9.0	0.0904+ 0.0904	0.75+0.75	0.050x4	0.4x4			
FFA50A2VEB	x3 RZAG125M7Y1B				13.2	-	16	-	10.0	0.0904+ 0.0904	0.75+0.75	0.050x3	0.4x3			
FBA35A2VEB	x4 RZAG125M7Y1B				13.4	-	16	-	9.0	0.0904+ 0.0904	0.75+0.75	0.089x4	0.6x4			
FBA50A2VEB	x3 RZAG125M7Y1B				13.8	-	16	-	10.0	0.0904+ 0.0904	0.75+0.75	0.089x3	0.6x3			
FBA71A2VEB	x2 RZAG125M7Y1B				14.6	-	16	-	11.5	0.0904+ 0.0904	0.75+0.75	0.07x2	0.5x2			
FBA140A2VEB	RZAG125M7Y1B				15.1	-	16	-	11.5	0.0904+ 0.0904	0.75+0.75	0.187	1.5			
FUA71AVEB	x2 RZAG125M7Y1B				15.4	-	16	-	11.5	0.0904+ 0.0904	0.75+0.75	0.046x2	0.9x2			
FAA71AUVEB	x2 RZAG125M7Y1B				14.4	-	16	-	11.5	0.0904+ 0.0904	0.75+0.75	0.048x2	0.4x2			
FVA140AMVEB	RZAG125M7Y1B				15.0	-	16	-	11.5	0.0904+ 0.0904	0.75+0.75	0.276	1.4			
FDXM35F3V1B	x4 RZAG125M7Y1B				12.2	-	16	-	9.0	0.0904+ 0.0904	0.75+0.75	0.034	0.3x4			
FDXM50F3V1B	x3 RZAG125M7Y1B				13.5	-	16	-	10.0	0.0904+ 0.0904	0.75+0.75	0.060x3	0.5x3			
FHA35AVEB	x4 RZAG125M7Y1B				13.4	-	16	-	9.0	0.0904+ 0.0904	0.75+0.75	0.060x4	0.6x4			
FHA50AVEB	x3 RZAG125M7Y1B				13.8	-	16	-	10.0	0.0904+ 0.0904	0.75+0.75	0.060x3	0.6x3			
FHA71AVEB	x2 RZAG125M7Y1B				15.2	-	16	-	11.5	0.0904+ 0.0904	0.75+0.75	0.091x2	0.8x2			
FHA140AVEB	RZAG125M7Y1B				15.4	-	16	-	11.5	0.0904+ 0.0904	0.75+0.75	0.150	1.8			
FCAHG71GVEB	x2 RZAG140M7Y1B				3N~50Hz 380-415V	Minimum: 342 V	Maximum: 456 V	14.6	-	16	-	11.5	0.0904+ 0.0904	0.75+0.75	0.091x2	0.5x2
FCAHG140GVEB	RZAG140M7Y1B							15.0	-	16	-	11.5	0.0904+ 0.0904	0.75+0.75	0.244	1.4
FCAG35AVEB	x4 RZAG140M7Y1B							12.2	-	16	-	9.0	0.0904+ 0.0904	0.75+0.75	0.044x4	0.3x4
FCAG50AVEB	x3 RZAG140M7Y1B							12.9	-	16	-	10.0	0.0904+ 0.0904	0.75+0.75	0.039x3	0.3x3
FCAG71AVEB	x2 RZAG140M7Y1B							14.4	-	16	-	11.5	0.0904+ 0.0904	0.75+0.75	0.054x2	0.4x2
FCAG140AVEB	RZAG140M7Y1B							14.6	-	16	-	11.5	0.0904+ 0.0904	0.75+0.75	0.168	1.0
FFA35A2VEB	x4 RZAG140M7Y1B							12.6	-	16	-	9.0	0.0904+ 0.0904	0.75+0.75	0.050x4	0.4x4
FFA50A2VEB	x3 RZAG140M7Y1B	13.2	-	16				-	10.0	0.0904+ 0.0904	0.75+0.75	0.050x3	0.4x3			
FBA35A2VEB	x4 RZAG140M7Y1B	13.4	-	16				-	9.0	0.0904+ 0.0904	0.75+0.75	0.089x4	0.6x4			
FBA50A2VEB	x3 RZAG140M7Y1B	13.8	-	16				-	10.0	0.0904+ 0.0904	0.75+0.75	0.089x3	0.6x3			
FBA71A2VEB	x2 RZAG140M7Y1B	14.6	-	16				-	11.5	0.0904+ 0.0904	0.75+0.75	0.07x2	0.5x2			
FBA140A2VEB	RZAG140M7Y1B	15.1	-	16				-	11.5	0.0904+ 0.0904	0.75+0.75	0.187	1.5			
FUA71AVEB	x2 RZAG140M7Y1B	15.4	-	16				-	11.5	0.0904+ 0.0904	0.75+0.75	0.046x2	0.9x2			
FAA71AUVEB	x2 RZAG140M7Y1B	14.4	-	16				-	11.5	0.0904+ 0.0904	0.75+0.75	0.048x2	0.4x2			
FVA140AMVEB	RZAG140M7Y1B	15.0	-	16				-	11.5	0.0904+ 0.0904	0.75+0.75	0.276	1.4			
FDXM35F3V1B	x4 RZAG140M7Y1B	12.2	-	16				-	9.0	0.0904+ 0.0904	0.75+0.75	0.034x4	0.3x4			
FDXM50F3V1B	x3 RZAG140M7Y1B	13.5	-	16				-	10.0	0.0904+ 0.0904	0.75+0.75	0.060x3	0.5x3			
FHA35AVEB	x4 RZAG140M7Y1B	13.4	-	16				-	9.0	0.0904+ 0.0904	0.75+0.75	0.060x4	0.6x4			
FHA50AVEB	x3 RZAG140M7Y1B	13.8	-	16				-	10.0	0.0904+ 0.0904	0.75+0.75	0.060x3	0.6x3			
FHA71AVEB	x2 RZAG140M7Y1B	15.2	-	16				-	11.5	0.0904+ 0.0904	0.75+0.75	0.091x2	0.8x2			
FHA140AVEB	RZAG140M7Y1B	15.4	-	16				-	11.5	0.0904+ 0.0904	0.75+0.75	0.150	1.8			

RZAG125-140MY1

3D110015A

RZASG71-100MV1

Indoor	Outdoor	Power supply	Voltage range	MCA	TOCA	MFA	Compressor		OFM		IFM					
							MSC	RLA	kW	FLA	kW	FLA				
FCAG35AVEB	x2	50 Hz ~ 220-240 V	Minimum: 198 V	Maximum: 264 V	17.6	-	20	-	0.094	0.094	0.9	0.044x2	0.3x2			
FCAG71AVEB					17.4	-	20	-	0.094	0.094	0.9	0.054	0.4			
FFA35A2VEB	x2				17.8	-	20	-	0.094	0.094	0.9	0.050x2	0.4x2			
FBA35A2VEB	x2				18.2	-	20	-	0.094	0.094	0.9	0.089x2	0.6x2			
FBA71A2VEB					17.5	-	20	-	0.094	0.094	0.9	0.070	0.5			
FNA35A2VEB	x2				17.3	-	20	-	0.094	0.094	0.9	0.034	0.3			
FUA71AVEB					17.9	-	20	-	0.094	0.094	0.9	0.046	0.9			
FAA71AUVEB					17.4	-	20	-	0.094	0.094	0.9	0.048	0.4			
FVA71AMVEB					17.6	-	20	-	0.094	0.094	0.9	0.117	0.6			
FDXM35F3V1B	x2				17.6	-	20	-	0.094	0.094	0.9	0.034x2	0.3x2			
FHA35AVEB	x2				18.2	-	20	-	0.094	0.094	0.9	0.060x2	0.6x2			
FHA71AVEB					17.8	-	20	-	0.094	0.094	0.9	0.091	0.8			
FCAG35AVEB	x3				50 Hz ~ 220-240 V	Minimum: 198 V	Maximum: 264 V	21.7	-	25	-	0.200	0.200	1.0	0.044x3	0.3x3
FCAG50AVEB	x2							21.4	-	25	-	0.200	0.200	1.0	0.039x2	0.3x2
FCAG100AVEB								21.5	-	25	-	0.200	0.200	1.0	0.117	0.7
FFA35A2VEB	x3							22.0	-	25	-	0.200	0.200	1.0	0.050x3	0.4x3
FFA50A2VEB	x2	21.6	-	25				-	0.200	0.200	1.0	0.050x2	0.4x2			
FBA100A2VEB		21.8	-	25				-	0.200	0.200	1.0	0.127	1.0			
FNA35A2VEB	x3	21.7	-	25				-	0.200	0.200	1.0	0.034x3	0.3x3			
FNA50A2VEB	x2	21.8	-	25				-	0.200	0.200	1.0	0.060x2	0.5x2			
FUA100AVEB		22.2	-	25				-	0.200	0.200	1.0	0.106	1.3			
FAA100AUVEB		21.2	-	25				-	0.200	0.200	1.0	0.064	0.4			
FVA100AMVEB		22.0	-	25				-	0.200	0.200	1.0	0.238	1.2			
FDXM35F3V1B	x3	21.7	-	25				-	0.200	0.200	1.0	0.034x3	0.3x3			
FDXM50F3V1B	x2	21.8	-	25				-	0.200	0.200	1.0	0.060x2	0.5x2			
FHA35AVEB	x3	22.7	-	25				-	0.200	0.200	1.0	0.060x3	0.6x3			
FHA50AVEB	x2	22.0	-	25				-	0.200	0.200	1.0	0.060x2	0.6x2			
FHA100AVEB		22.2	-	25				-	0.200	0.200	1.0	0.150	1.3			

RZASG71-100MV1

3D110014A



RZAG-MY1

Symbols	Notes
MCA Min. Circuit Amps. (A) TOCA Total Over-Current Amps. (A) MFA Max. Fuse Amps (See note 7) (A) MSC Max. current during the starting compressor. (A) RLA Rated Load Amps. (A) OFM Outdoor Fan Motor. (A) IFM Indoor Fan Motor. FLA Full Load Amps. kW Fan Motor Rated Output (kW)	<p>1 RLA is based on the following indoor conditions:</p> <p>Cooling Indoor temperature 27.0°CDB/19.0°CWB Outdoor temperature 35.0°CDB</p> <p>Heating Indoor temperature 20.0°CDB Outdoor temperature 7.0°CDB/6.0°CWB.</p> <p>2 TOCA means the total value of each OC set.</p> <p>3 Voltage range Units are suitable for use on electrical systems where voltage supplied to unit terminals is not below or above listed range limits.</p> <p>4 Maximum allowable voltage variation between phases is 2% .</p> <p>5 MCA is the maximum input current. The capacity of the MFA must be greater than that of the MCA. Select the MFA according to the table.</p> <p>6 Select the wire size according to the MCA.</p> <p>7 MFA is used to select the circuit breaker and the ground fault circuit interrupter. (earth leakage circuit breaker)</p>



RZAG71-MV1/MY1

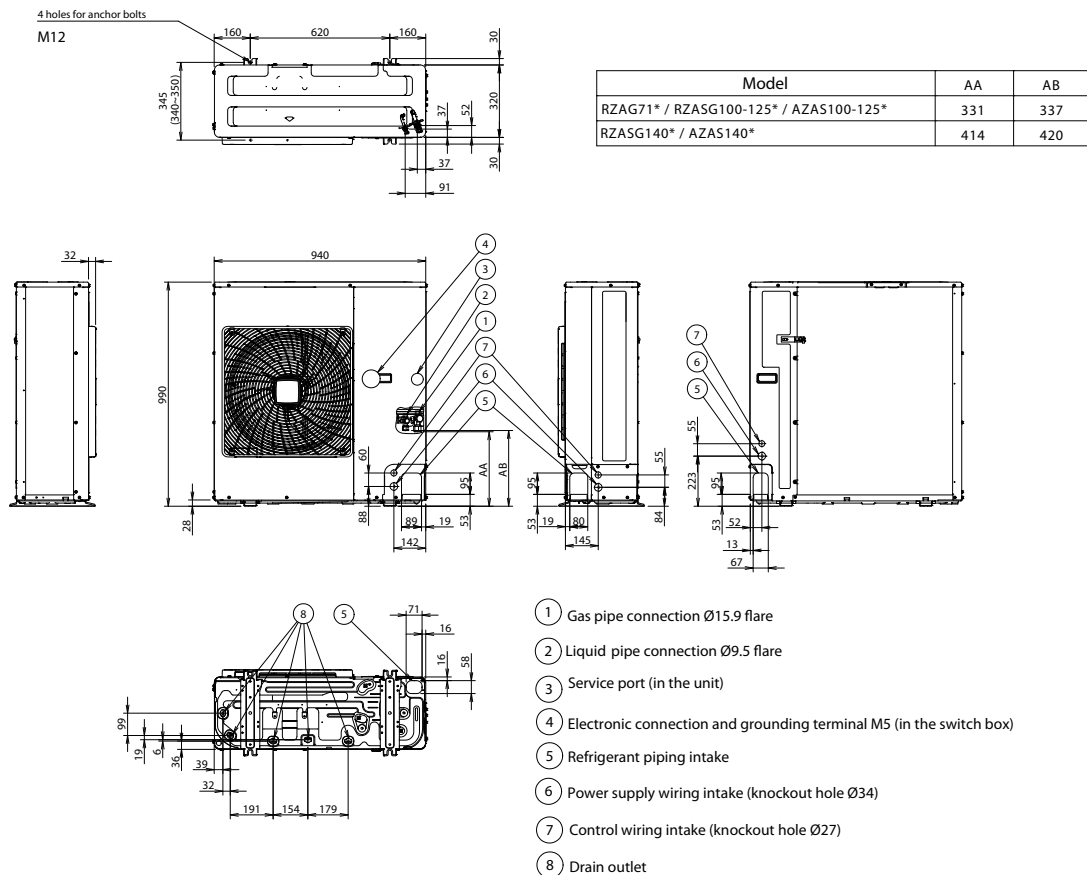

3D110011

RZAG100-140MV1/MY1

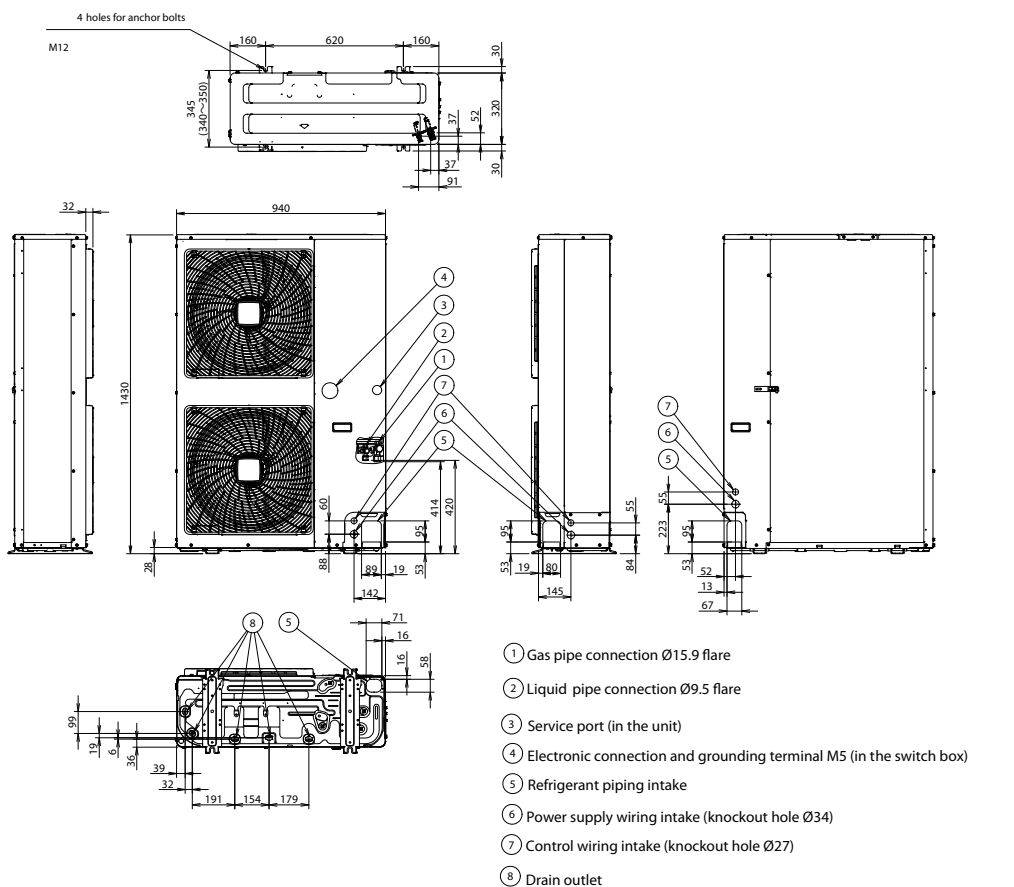

3D110012



RZAG-MV1/MY1

Installation service space

The measure of these values is "mm".

(A) When there are obstacles on suction sides.

• No obstacle above

- ① Stand-alone installation
 - Obstacle on the suction side only

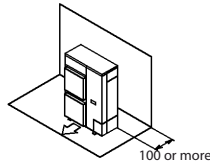

- Obstacle on both sides and suction side, too

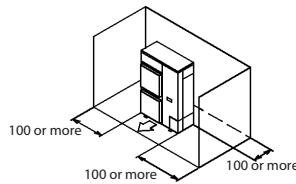

- ② Series installation (2 or more) (Note 1)
 - Obstacle on the suction side and both sides

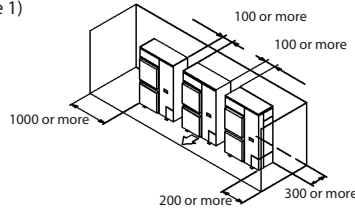

• Obstacle above, too.

- ① Stand-alone installation
 - Obstacle on the suction side, too

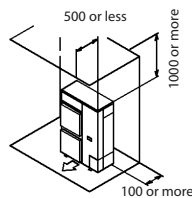

- Obstacle on both sides and suction side, too

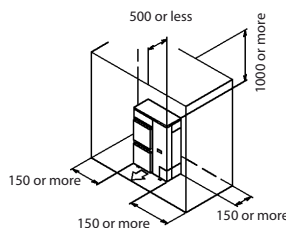

- ② Series installation (2 or more) (Note 1)
 - Obstacle on the suction side and both sides

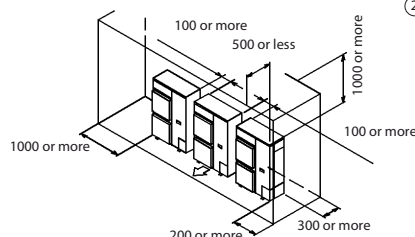

(B) When there are obstacles on discharge sides.

• No obstacle above

- ① Stand-alone installation
 - Obstacle on the discharge side only

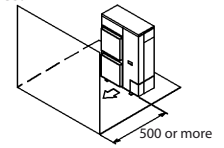

- ② Series installation (2 or more) (Note 1)
 - Obstacle on the suction side only

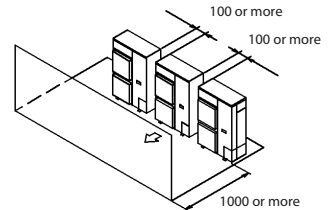

• Obstacle above, too.

- ① Stand-alone installation
 - Obstacle on the discharge side only, too

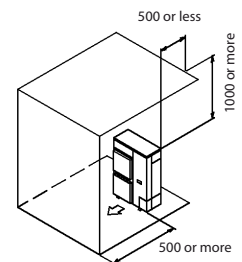

- ② Series installation (2 or more) (Note 1)
 - Obstacle on discharge side

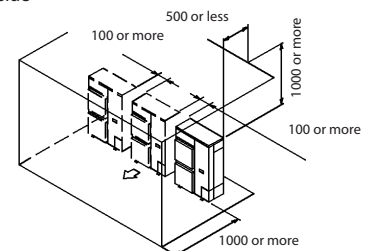

(C) When there are obstacles on both suction and discharge sides:

Pattern 1

When the obstacles on the discharge side is higher than the unit. (L > H)
(There is no limit for the height of obstructions on the suction side.)

• No obstacle above

- ① Stand-alone installation
 - No obstacle above

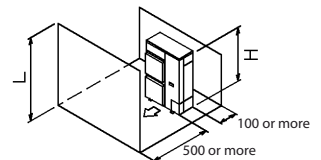

- ② Series installation (2 or more) (Note 1)
 - No obstacle above

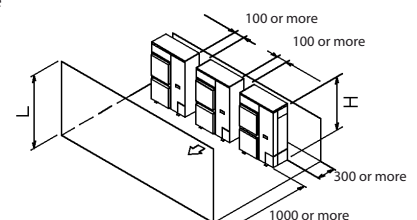



RZAG-MV1/MY1

• Obstacle above, too

- ① Stand-alone installation (Note 2)
 - When there are obstacles on suction, discharge and top sides.

The relations between H, A and L are as follows.

	L	A
$L \leq H$	$L \leq 1/2 H$ $1/2 H < L \leq H$	750 or more 1000 or more
$L > H$	Set the stand as: $L \leq H$ Refer to the column of $L \leq H$ for A	

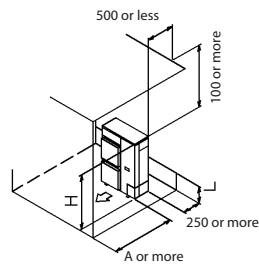

- ② Series installation (2 or more) (Note 1,2)
 - When there are obstacles on suction, discharge and top sides.

The relations between H, A and L are as follows.

	L	A
$L \leq H$	$L \leq 1/2 H$ $1/2 H < L \leq H$	1000 or more 1250 or more
$L > H$	Set the stand as: $L \leq H$ Refer to the column of $L \leq H$ for A	

Limit of series installation is 2 units.

Pattern 2

When the obstacle on the discharge side is lower than the unit ($L \leq H$) (There is no limit for the height of obstructions on the suction side.)

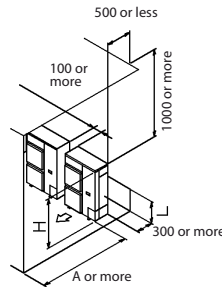

• No obstacle above

- ① Stand-alone installation
 - No obstacle above

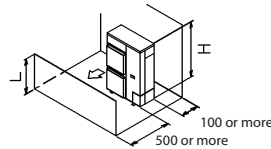

- ② Series installation (2 or more) (Note 1,2)
 - When there are obstacles on both suction and discharge sides.

The relations between H, A and L are as follows.

	L	A
$L \leq H$	$L \leq 1/2 H$ $1/2 H < L \leq H$	250 or more 300 or more

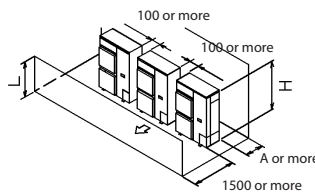

• Obstacle above

- ① Stand-alone installation (Note 2)
 - When there are obstacles on suction, discharge and top sides.

The relations between H, A and L are as follows.

	L	A
$L \leq H$	$L \leq 1/2 H$ $1/2 H < L \leq H$	100 or more 200 or more
$L > H$	Set the stand as: $L \leq H$ Refer to the column of $L \leq H$ for A	

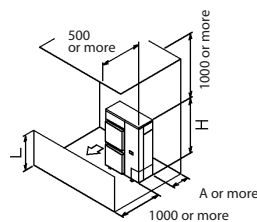

- ② Series installation (2 or more) (Note 1,2)
 - When there are obstacles on suction, discharge and top sides.

The relations between H, A and L are as follows.

	L	A
$L \leq H$	$L \leq 1/2 H$ $1/2 H < L \leq H$	250 or more 300 or more
$L > H$	Set the stand as: $L \leq H$ Refer to the column of $L \leq H$ for A	

Limit of series installation is 2 units.

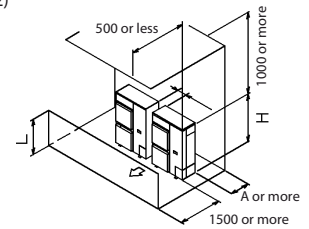

(D) Double-decker installation

- ① Obstacle on the discharge side. (1)
 - Do not exceed two levels for stacked installation.
 - Install a roof cover similar to A (field supply), as outdoor units with downward drainage are prone to dripping and freezing.
 - Install the upper-level outdoor unit so that its bottom plate is a sufficient height above the roof cover. This is to prevent the buildup of ice on the underside of the bottom plate.

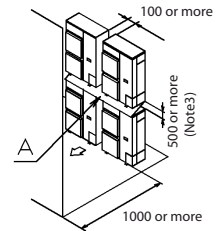

- ② Obstacle on the suction side. (1)
 - Do not exceed two levels for stacked installation.
 - Install a roof cover similar to A (field supply), as outdoor units with downward drainage are prone to dripping and freezing.
 - Install the upper-level outdoor unit so that its bottom plate is a sufficient height above the roof cover. This is to prevent the buildup of ice on the underside of the bottom plate.

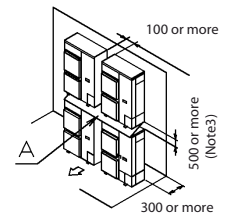

(E) Multiple rows of series installation (on the rooftop, etc.)

- ① One row of stand-alone installation

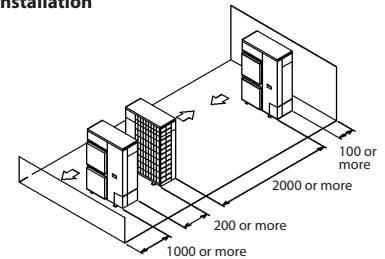

- ② Rows of series installation (2 or more)

The relations between H, A and L are as follows.

	L	A
$L \leq H$	$L \leq 1/2 H$ $1/2 H < L \leq H$	250 or more 300 or more
$L > H$	Can not be installed	

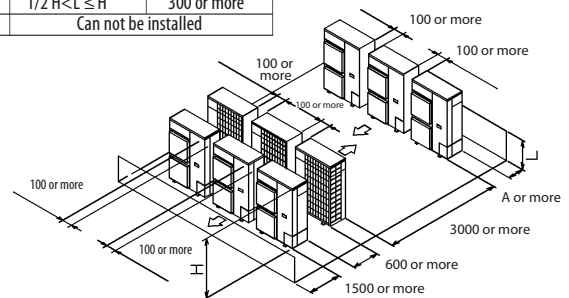

NOTES

- In case of the sideways piping, make a 100mm gap between the unit above.
- Close the bottom of the installation frame to prevent the discharged air from being bypassed.
- It is not necessary to install a roof cover if there is no danger of drainage dripping and freezing. In this case, the space between the upper and lower outdoor units should be at least 100mm. Close off the gap between the upper and lower units so there is no reintake of discharged air.



Detailed technical drawings

RZAG-MV1/MY1

To determine if adding additional refrigerant is necessary

If	Then
$(L1+L2+L3+L4+L5+L6+L7) \leq$ chargeless length Chargeless length= 10 m (size-down) 40 m (standard) 15 m (size-up)	You do not have to add additional refrigerant.
$(L1+L2+L3+L4+L5+L6+L7) >$ chargeless length	You must add additional refrigerant. For future servicing, encircle the selected amount in the tables below.

INFORMATION

Piping length is the largest one way length of liquid piping.

To determine the additional refrigerant amount (R in kg) (in case of pair)

Standard piping size:

L1 (standard):	40~50 m	50~55 m	55~60 m ^(a)	60~75 m ^(a)	75~85 m ^(a)
R:	0.35 kg	0.7 kg ^(a) 0.55 kg ^(b)	0.7 kg	1.05 kg	1.55 kg

a) Only for RZAG100~140.

b) Only for RZAG71.

Size-up piping size:

L1 (size-up):	15~20 m	20~25 m	20~25 m ^(a)	30~35 m ^(a)
R:	0.35 kg	0.7 kg	1.05 kg	1.4 kg

a) Only for RZAG100~140.

To determine the additional refrigerant amount (R in kg) (in case of twin, triple and double twin)

1. Determine G1 and G2.

G1 (m)	Total length of <x> liquid piping x= Ø9.5 mm (standard) x= Ø12.7 mm (size-up)
G2 (m)	Total length of Ø6.4 mm liquid piping

2. Determine R1 and R2.

If	Then
$G1 > 40$ m ^(a)	Use the table below to determine R1 (length= $G1-40$ m) ^(a) and R2 (length=g2). R1=0.0 kg.
$G1 \leq 40$ m ^(a) (and $G1+G2 > 40$ m) ^(a)	Use the table below to determine R2 (length= $G1+G2-40$ m) ^(a)

a) In case of size-up: Replace 40 m by 15 m.

In case of standard liquid pipe size:

	Lenght				
	0~10 m	10~20 m	20~30 m	30~40 m	40~45 m
R1:	0.35 kg	0.7 kg	1.05 kg ^(a)		1.4 kg ^(a)
R2:	0.2 kg	0.4 kg	0.6 kg	0.8 kg ^(a)	1 kg ^(b)

In case of size-up liquid pipe size:

	Lenght						
	0~5 m	5~10 m	10~15 m ^(a)	15~20 m ^(a)	20~30 m	30~40m	40~45m
R1:	0.35 kg	0.7 kg	1.05 kg	1.4 kg	-	-	-
R2:		0.35 kg		0.7 kg	1.05 kg	1.4 kg	-

a) Only for RZAG100~140.

b) Only for RZAG125-140.

3. Determine the additional refrigerant amount: R=R1+R2.

Examples

Layout	Additional refrigerant amount (R)	
	Case: Twin, standard liquid pipe size	
	1.	G1 Total Ø9.5 => G1=45 m G2 Total Ø6.4 => G2=7+5=12 m
	2.	Case: $G1 > 40$ m R1 Length= $G1-40$ m=5 m => R1=0.35 kg R2 Length= $G2=12$ m => R2=0.4 kg
	Case: Triple, standard liquid pipe size	
	1.	G1 Total Ø9.5 => G1=15 m G2 Total Ø6.4 => G2=20+17+17=54 m
	2.	Case: $G1 \leq 40$ m (and $G1+G2 > 40$ m) R1 R1=0.0 kg R2 Length= $G1+G2-40$ m=15+54-40=29 m => R2=0.6 kg
	3.	R R=R1+R2=0.0+0.6=0.6 kg



RZASG71-100MV1

Indoor	Outdoor	Power supply	Voltage range	MCA	TOCA	MFA	Compressor		OFM		IFM					
							MSC	RLA	kW	FLA	kW	FLA				
FCAG35AVEB	x2 RZASG71M2V1B	50 Hz~ 220- 240 V	Minimum: 198 V	Maximum: 264 V	17.6	-	20	-	15.4	0.094	0.9	0.044x2	0.3x2			
FCAG71AVEB	RZASG71M2V1B				17.4	-	20	-	15.4	0.094	0.9	0.054	0.4			
FFA35A2VEB	x2 RZASG71M2V1B				17.8	-	20	-	15.4	0.094	0.9	0.050x2	0.4x2			
FBA35A2VEB	x2 RZASG71M2V1B				18.2	-	20	-	15.4	0.094	0.9	0.089x2	0.6x2			
FBA71A2VEB	RZASG71M2V1B				17.5	-	20	-	15.4	0.094	0.9	0.070	0.5			
FNA35A2VEB	x2 RZASG71M2V1B				17.3	-	20	-	15.4	0.094	0.9	0.034x2	0.3			
FUA71AVEB	RZASG71M2V1B				17.9	-	20	-	15.4	0.094	0.9	0.046	0.9			
FAA71AUVEB	RZASG71M2V1B				17.4	-	20	-	15.4	0.094	0.9	0.048	0.4			
FVA71AMVEB	RZASG71M2V1B				17.6	-	20	-	15.4	0.094	0.9	0.117	0.6			
FDXM35F3V1B	x2 RZASG71M2V1B				17.6	-	20	-	15.4	0.094	0.9	0.034x2	0.3x2			
FHA35AVEB	x2 RZASG71M2V1B				18.2	-	20	-	15.4	0.094	0.9	0.060x2	0.6x2			
FHA71AVEB	RZASG71M2V1B				17.8	-	20	-	15.4	0.094	0.9	0.091	0.8			
FCAG35AVEB	x3 RZASG100M7V1B				50 Hz~ 220- 240 V	Minimum: 198 V	Maximum: 264 V	21.7	-	25	-	19.0	0.200	1.0	0.044x3	0.3x3
FCAG50AVEB	x2 RZASG100M7V1B							21.4	-	25	-	19.0	0.200	1.0	0.039x2	0.3x2
FCAG100AVEB	RZASG100M7V1B	21.5	-	25				-	19.0	0.200	1.0	0.117	0.7			
FFA35A2VEB	x3 RZASG100M7V1B	22.0	-	25				-	19.0	0.200	1.0	0.050x3	0.4x3			
FFA50A2VEB	x2 RZASG100M7V1B	21.6	-	25				-	19.0	0.200	1.0	0.050x2	0.4x2			
FBA100A2VEB	RZASG100M7V1B	21.8	-	25				-	19.0	0.200	1.0	0.127	1.0			
FNA35A2VEB	x3 RZASG100M7V1B	21.7	-	25				-	19.0	0.200	1.0	0.034x3	0.3x3			
FNA50A2VEB	x2 RZASG100M7V1B	21.8	-	25				-	19.0	0.200	1.0	0.060x2	0.5x2			
FUA100AVEB	RZASG100M7V1B	22.2	-	25				-	19.0	0.200	1.0	0.106	1.3			
FAA100AUVEB	RZASG100M7V1B	21.2	-	25				-	19.0	0.200	1.0	0.064	0.4			
FVA100AMVEB	RZASG100M7V1B	22.0	-	25				-	19.0	0.200	1.0	0.238	1.2			
FDXM35F3V1B	x3 RZASG100M7V1B	21.7	-	25				-	19.0	0.200	1.0	0.034x3	0.3x3			
FDXM50F3V1B	x2 RZASG100M7V1B	21.8	-	25				-	19.0	0.200	1.0	0.060x2	0.5x2			
FHA35AVEB	x3 RZASG100M7V1B	22.7	-	25				-	19.0	0.200	1.0	0.060x3	0.6x3			
FHA50AVEB	x2 RZASG100M7V1B	22.0	-	25				-	19.0	0.200	1.0	0.060x2	0.6x2			
FHA100AVEB	RZASG100M7V1B	22.2	-	25				-	19.0	0.200	1.0	0.150	1.3			

RZASG71- 100MV1

3D110014A

RZASG125-140MV1

Indoor	Outdoor	Power supply	Voltage range	MCA	TOCA	MFA	Compressor		OFM		IFM			
							MSC	RLA	kW	FLA	kW	FLA		
FCAG35AVEB	x4 RZASG125M7V1B	50 Hz~ 220- 240 V	Minimum: 198 V	Maximum: 264 V	28.0	-	32	-	24.7	0.200	1.0	0.044x4	0.3x4	
FCAG50AVEB	x3 RZASG125M7V1B				27.7	-	32	-	24.7	0.200	1.0	0.039x3	0.3x3	
FCAG60AVEB	x2 RZASG125M7V1B				27.4	-	32	-	24.7	0.200	1.0	0.044x2	0.3x2	
FCAG125AVEB	RZASG125M7V1B				27.8	-	32	-	24.7	0.200	1.0	0.168	1.0	
FFA35A2VEB	x4 RZASG125M7V1B				28.4	-	32	-	24.7	0.200	1.0	0.050x4	0.4x4	
FFA50A2VEB	x3 RZASG125M7V1B				28.0	-	32	-	24.7	0.200	1.0	0.050x3	0.4x3	
FFA60A2VEB	x2 RZASG125M7V1B				28.0	-	32	-	24.7	0.200	1.0	0.050x2	0.6x2	
FBA35A2VEB	x4 RZASG125M7V1B				29.2	-	32	-	24.7	0.200	1.0	0.089x4	0.6x4	
FBA50A2VEB	X3 RZASG125M7V1B				28.6	-	32	-	24.7	0.200	1.0	0.089x3	0.6x3	
FBA60A2VEB	x2 RZASG125M7V1B				27.8	-	32	-	24.7	0.200	1.0	0.070x2	0.5x2	
FBA125A2VEB	RZASG125M7V1B				28.3	-	32	-	24.7	0.200	1.0	0.187	1.5	
FNA35A2VEB	X4 RZASG125M7V1B				28.0	-	32	-	24.7	0.200	1.0	0.034x4	0.3x4	
FNA50A2VEB	x3 RZASG125M7V1B				28.3	-	32	-	24.7	0.200	1.0	0.060x3	0.5x3	
FNA60A2VEB	x2 RZASG125M7V1B				27.8	-	32	-	24.7	0.200	1.0	0.060x2	0.5x2	
FUA125AVEB	RZASG125M7V1B				28.2	-	32	-	24.7	0.200	1.0	0.106	1.4	
FDA125AVEB	RZASG125M7V1B				28.9	-	32	-	24.7	0.200	1.0	0.350	2.1	
FVA125AMVEB	RZASG125M7V1B				28.0	-	32	-	24.7	0.200	1.0	0.238	1.2	
FDXM35F3V1B	x4 RZASG125M7V1B				28.0	-	32	-	24.7	0.200	1.0	0.034x4	0.3x4	
FDXM50F3V1B	x3 RZASG125M7V1B				28.3	-	32	-	24.7	0.200	1.0	0.060x3	0.5x3	
FDXM60F3V1B	x2 RZASG125M7V1B				27.8	-	32	-	24.7	0.200	1.0	0.060x2	0.5x2	
FHA35AVEB	x4 RZASG125M7V1B	29.2	-	32	-	24.7	0.200	1.0	0.060x4	0.6x4				
FHA50AVEB	x3 RZASG125M7V1B	28.6	-	32	-	24.7	0.200	1.0	0.060x3	0.6x3				
FHA60AVEB	x2 RZASG125M7V1B	28.0	-	32	-	24.7	0.200	1.0	0.091x2	0.6x2				
FHA125AVEB	RZASG125M7V1B	28.3	-	32	-	24.7	0.200	1.0	0.150	1.5				
FCAG35AVEB	x4 RZASG140M7V1B	50 Hz~ 220- 240 V	Minimum: 198 V	Maximum: 264 V	27.2	-	32	-	24.0	0.200	1.0	0.044x4	0.3x4	
FCAG50AVEB	x3 RZASG140M7V1B				26.9	-	32	-	24.0	0.200	1.0	0.039x3	0.3x3	
FCAG71AVEB	X2 RZASG140M7V1B				26.8	-	32	-	24.0	0.200	1.0	0.054x2	0.4x2	
FCAG140AVEB	RZASG140M7V1B				27.0	-	32	-	24.0	0.200	1.0	0.168	1.0	
FFA35A2VEB	x4 RZASG140M7V1B				27.7	-	32	-	24.0	0.200	1.0	0.050x4	0.4x4	
FFA50A2VEB	x3 RZASG140M7V1B				27.2	-	32	-	24.0	0.200	1.0	0.050x3	0.4x3	
FBA35A2VEB	x4 RZASG140M7V1B				28.5	-	32	-	24.0	0.200	1.0	0.089x4	0.6x4	
FBA50A2VEB	x3 RZASG140M7V1B				27.9	-	32	-	24.0	0.200	1.0	0.089x3	0.6x3	
FBA71A2VEB	x2 RZASG140M7V1B				27.0	-	32	-	24.0	0.200	1.0	0.070x2	0.5x2	
FBA140A2VEB	RZASG140M7V1B				27.6	-	32	-	24.0	0.200	1.0	0.187	1.5	
FNA35A2VEB	x4 RZASG140M7V1B				27.2	-	32	-	24.0	0.200	1.0	0.034x4	0.3x4	
FNA50A2VEB	x3 RZASG140M7V1B				27.6	-	32	-	24.0	0.200	1.0	0.060x3	0.5x3	
FUA71AVEB	x2 RZASG140M7V1B				27.9	-	32	-	24.0	0.200	1.0	0.046x2	0.9x2	
FAA71AUVEB	x2 RZASG140M7V1B				26.8	-	32	-	24.0	0.200	1.0	0.048x2	0.4x2	
FVA71AMVEB	x2 RZASG140M7V1B				27.2	-	32	-	24.0	0.200	1.0	0.117x2	0.6x2	
FVA140AMVEB	RZASG140M7V1B				27.5	-	32	-	24.0	0.200	1.0	0.276	1.4	
FDXM35F3V1B	x4 RZASG140M7V1B				27.2	-	32	-	24.0	0.200	1.0	0.034x4	0.3x4	
FDXM50F3V1B	x3 RZASG140M7V1B				27.6	-	32	-	24.0	0.200	1.0	0.060x3	0.5x3	
FHA35AVEB	x4 RZASG140M7V1B				28.5	-	32	-	24.0	0.200	1.0	0.060x4	0.6x4	
FHA50AVEB	x3 RZASG140M7V1B				27.9	-	32	-	24.0	0.200	1.0	0.060x3	0.6x3	
FHA71AVEB	x2 RZASG140M7V1B	27.7	-	32	-	24.0	0.200	1.0	0.091x2	0.8x2				
FHA140AVEB	RZASG140M7V1B	27.9	-	32	-	24.0	0.200	1.0	0.150	1.8				

RZASG125- 140MV1

3D110014A



Detailed technical drawings

RZASG100MY1

Indoor	Outdoor	Power supply	Voltage range		MCA	TOCA	MFA	Compressor		OFM		IFM	
								MSC	RLA	kW	FLA	kW	FLA
FCAG35AVEB	x3 RZASG100M7Y1B	3 N~ 50Hz 380- 415 V	Minimum: 342 V	Maximum: 456 V	13.0	-	16	-	10.6	0.200	1.0	0.044x3	0.3x3
FCAG50AVEB	x2 RZASG100M7Y1B				12.7	-	16	-	10.6	0.200	1.0	0.039x2	0.3x2
FCAG100AVEB	RZASG100M7Y1B				14.2	-	16	-	12.0	0.200	1.0	0.117	0.7
FFA35A2VEB	x3 RZASG100M7Y1B				13.3	-	16	-	10.6	0.200	1.0		0.4x3
FFA50A2VEB	x2 RZASG100M7Y1B				12.9	-	16	-	10.6	0.200	1.0	0.050x2	0.4x2
FBA100A2VEB	RZASG100M7Y1B				14.6	-	16	-	12.0	0.200	1.0	0.127	1.0
FNA35A2VEB	x3 RZASG100M7Y1B				13.0	-	16	-	10.6	0.200	1.0	0.034x3	0.3x3
FNA50A2VEB	x2 RZASG100M7Y1B				13.1	-	16	-	10.6	0.200	1.0	0.060x2	0.5x2
FUA100AVEB	RZASG100M7Y1B				14.9	-	16	-	12.0	0.200	1.0	0.106	1.3
FAA100AUEB	RZASG100M7Y1B				13.9	-	16	-	12.0	0.200	1.0	0.064	0.4
FVA100AMVEB	RZASG100M7Y1B				14.8	-	16	-	12.0	0.200	1.0	0.238	1.2
FDXM34F3V1B	x3 RZASG100M7Y1B				13.0	-	16	-	10.6	0.200	1.0	0.034x3	0.3x3
FDXM50F3V1B	x2 RZASG100M7Y1B				13.1	-	16	-	10.6	0.200	1.0	0.060x2	0.5x2
FHA35AVEB	x3 RZASG100M7Y1B				13.9	-	16	-	10.6	0.200	1.0	0.060x3	0.6x3
FHA50AVEB	x2 RZASG100M7Y1B				13.5	-	16	-	10.6	0.200	1.0	0.060x2	0.6x2
FHA100AVEB	RZASG100M7Y1B				14.9	-	16	-	12.0	0.200	1.0	0.150	1.3

RZASG100MY1

3D110014A

RZASG125-140MY1

Indoor	Outdoor	Power supply	Voltage range		MCA	TOCA	MFA	Compressor		OFM		IFM	
								MSC	RLA	kW	FLA	kW	FLA
FCAG35AVEB	x4 RZASG125M7Y1B	3 N~50Hz 380- 415 V	Minimum: 342 V	Maximum: 456V	12.2	-	16	-	9.5	0.200	1.0	0.044x4	0.3x4
FCAG50AVEB	x3 RZASG125M7Y1B				13.0	-	16	-	10.6	0.200	1.0	0.039x3	0.3x3
FCAG60AVEB	x2 RZASG125M7Y1B				12.7	-	16	-	10.6	0.200	1.0	0.044x2	0.3x2
FCAG125AVEB	RZASG125M7Y1B				14.6	-	16	-	12.0	0.200	1.0	0.168	1.0
FFA35A2VEB	x4 RZASG125M7Y1B				12.6	-	16	-	9.5	0.200	1.0	0.050x4	0.4x4
FFA50A2VEB	x3 RZASG125M7Y1B				13.3	-	16	-	10.6	0.200	1.0	0.050x3	0.4x3
FFA60A2VEB	x2 RZASG125M7Y1B				13.3	-	16	-	10.6	0.200	1.0	0.050x2	0.6x2
FBA35A2VEB	x4 RZASG125M7Y1B				13.4	-	16	-	9.5	0.200	1.0	0.089x4	0.6x4
FBA50A2VEB	x3 RZASG125M7Y1B				13.9	-	16	-	10.6	0.200	1.0	0.089x3	0.6x3
FBA60A2VEB	X2 RZASG125M7Y1B				13.1	-	16	-	10.6	0.200	1.0	0.070x2	0.5x2
FBA125A2VEB	RZASG125M7Y1B				15.1	-	16	-	12.0	0.200	1.0	0.187	1.5
FNA35A2VEB	x4 RZASG125M7Y1B				12.2	-	16	-	9.5	0.200	1.0	0.034x4	0.3x4
FNA50A2VEB	x3 RZASG125M7Y1B				13.6	-	16	-	10.6	0.200	1.0	0.060x3	0.5x3
FNA60A2VEB	x2 RZASG125M7Y1B				13.1	-	16	-	10.6	0.200	1.0	0.060x2	0.5x2
FUA125AVEB	RZASG125M7Y1B				15.0	-	16	-	12.0	0.200	1.0	0.106	1.4
FDA125A5VEB	RZASG125M7Y1B				15.7	-	16	-	12.0	0.200	1.0	0.350	2.1
FVA125AMVEB	RZASG125M7Y1B				14.8	-	16	-	12.0	0.200	1.0	0.238	1.2
FDXM35F3V1B	x4 RZASG125M7Y1B				12.2	-	16	-	9.5	0.200	1.0	0.034x3	0.3x4
FDXM50F3V1B	x3 RZASG125M7Y1B				13.6	-	16	-	10.6	0.200	1.0	0.060x3	0.5x3
FDXM60F3V1B	x2 RZASG125M7Y1B				13.1	-	16	-	10.6	0.200	1.0	0.060x2	0.5x2
FHA35AVEB	x4 RZASG125M7Y1B	13.4	-	16	-	9.5	0.200	1.0	0.060x4	0.6x4			
FHA50AVEB	x3 RZASG125M7Y1B	13.9	-	16	-	10.6	0.200	1.0	0.060x3	0.6x3			
FHA60AVEB	x2 RZASG125M7Y1B	13.3	-	16	-	10.6	0.200	1.0	0.091x2	0.6x2			
FHA125AVEB	RZASG125M7Y1B	15.1	-	16	-	12.0	0.200	1.0	0.150	1.5			
FCAG35AVEB	x4 RZASG140M7Y1B	3 N~50Hz 380- 415 V	Minimum: 342 V	Maximum: 456V	12.2	-	16	-	9.5	0.200	1.0	0.044x4	0.3x4
FCAG50AVEB	x3 RZASG140M7Y1B				12.9	-	16	-	10.5	0.200	1.0	0.039x3	0.3x3
FCAG71AVEB	x2 RZASG140M7Y1B				14.4	-	16	-	12.0	0.200	1.0	0.054x2	0.4x2
FCAG140AVEB	RZASG140M7Y1B				14.6	-	16	-	12.0	0.200	1.0	0.168	1.0
FFA35A2VEB	x4 RZASG140M7Y1B				12.6	-	16	-	9.5	0.200	1.0	0.050x4	0.4x4
FFA50A2VEB	x3 RZASG140M7Y1B				13.2	-	16	-	10.5	0.200	1.0	0.050x3	0.4x3
FBA35A2VEB	x4 RZASG140M7Y1B				13.4	-	16	-	9.5	0.200	1.0	0.089x4	0.6x4
FBA50A2VEB	x3 RZASG140M7Y1B				13.8	-	16	-	10.5	0.200	1.0	0.089x3	0.6x3
FBA71A2VEB	x2 RZASG140M7Y1B				14.6	-	16	-	12.0	0.200	1.0	0.070x2	0.5x2
FBA140A2VEB	RZASG140M7Y1B				15.1	-	16	-	12.0	0.200	1.0	0.187	1.5
FNA35A2VEB	X4 RZASG140M7Y1B				12.2	-	16	-	9.5	0.200	1.0	0.034x4	0.3x4
FNA50A2VEB	X3 RZASG140M7Y1B				13.5	-	16	-	10.5	0.200	1.0	0.060x3	0.5x3
FUA71AVEB	X2 RZASG140M7Y1B				15.4	-	16	-	12.0	0.200	1.0	0.046x2	0.9x2
FAA71AUEB	X2 RZASG140M7Y1B				14.4	-	16	-	12.0	0.200	1.0	0.048x2	0.4x2
FVA71AMVEB	x2 RZASG140M7Y1B				14.8	-	16	-	12.0	0.200	1.0	0.117	0.6x2
FVA140AMVEB	RZASG140M7Y1B				15.0	-	16	-	12.0	0.200	1.0	0.276	1.4
FDXM35F3V1B	x4 RZASG140M7Y1B				12.2	-	16	-	9.5	0.200	1.0	0.034x4	0.3x4
FDXM50F3V1B	x3 RZASG140M7Y1B				13.5	-	16	-	10.5	0.200	1.0	0.060x3	0.5x3
FHA35AVEB	x4 RZASG140M7Y1B				13.4	-	16	-	9.5	0.200	1.0	0.060x4	0.6x4
FHA50AVEB	x3 RZASG140M7Y1B				13.8	-	16	-	10.5	0.200	1.0	0.060x3	0.6x3
FHA71AVEB	x2 RZASG140M7Y1B	15.2	-	16	-	12.0	0.200	1.0	0.091x2	0.8x2			
FHA140AVEB	RZASG140M7Y1B	15.4	-	16	-	12.0	0.200	1.0	0.150	1.8			

RZASG125-140MY1

3D110014A



RZASG-MV1/MY1

Symbols	Notes
MCA Min. Circuit Amps. (A)	<p>1 RLA is based on the following indoor conditions: Cooling Indoor temperature 27.0°CDB/19.0°CWB Outdoor temperature 35.0°CDB Heating Indoor temperature 20.0°CDB Outdoor temperature 7.0°CDB/6.0°CWB.</p> <p>2 TOCA means the total value of each OC set.</p> <p>3 Voltage range Units are suitable for use on electrical systems where voltage supplied to unit terminals is not below or above listed range limits.</p> <p>4 Maximum allowable voltage variation between phases is 2% .</p> <p>5 MCA is the maximum input current. The capacity of the MFA must be greater than that of the MCA. Select the MFA according to the table.</p> <p>6 Select the wire size according to the MCA.</p> <p>7 MFA is used to select the circuit breaker and the ground fault circuit interrupter. (earth leakage circuit breaker)</p>
TOCA Total Over-Current Amps. (A)	
MFA Max. Fuse Amps (See note 7) (A)	
MSC Max. current during the starting compressor. (A)	
RLA Rated Load Amps. (A)	
OFM Outdoor Fan Motor. (A)	
IFM Indoor Fan Motor.	
FLA Full Load Amps.	
kW Fan Motor Rated Output (kW)	

3D110014A.

RZASG71MV1

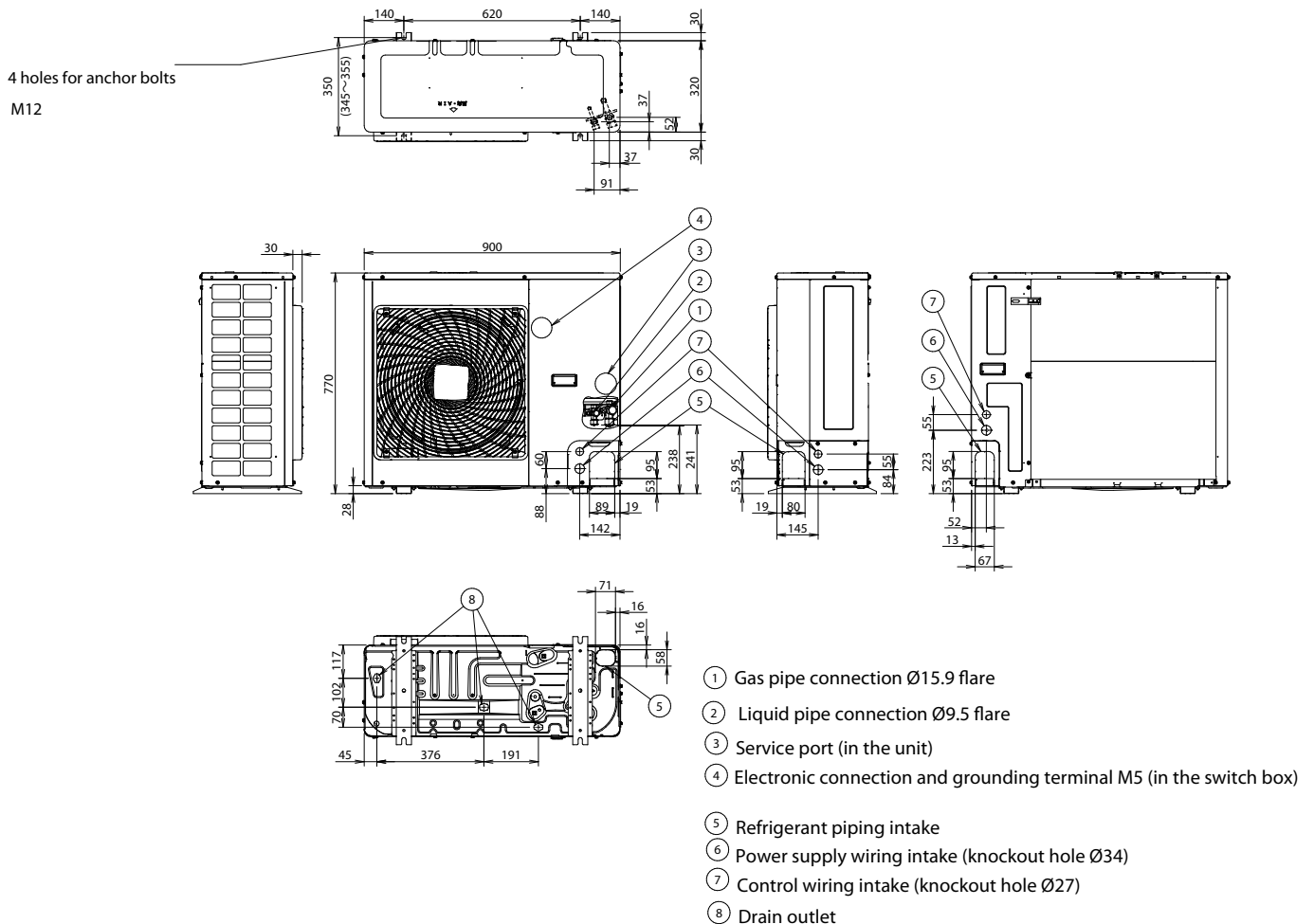



RZASG100-140MV1/MY1

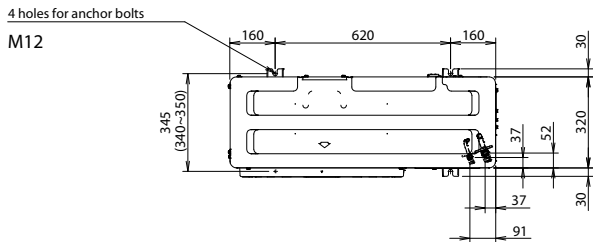

Model	AA	AB
RZAG71* / RZASG100-125* / AZAS100-125*	331	337
RZASG140* / AZAS140*	414	420

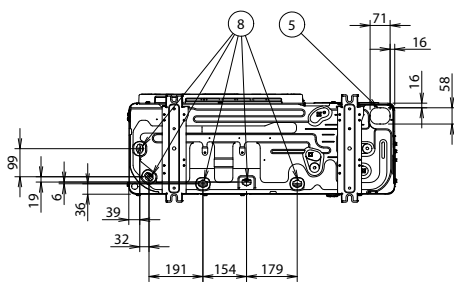
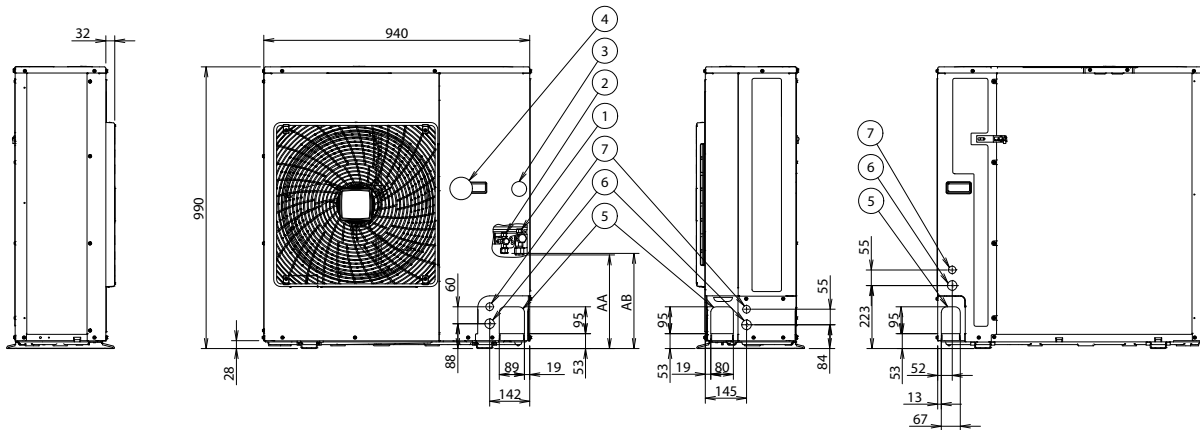

- ① Gas pipe connection Ø15.9 flare
- ② Liquid pipe connection Ø9.5 flare
- ③ Service port (in the unit)
- ④ Electronic connection and grounding terminal M5 (in the switch box)
- ⑤ Refrigerant piping intake
- ⑥ Power supply wiring intake (knockout hole Ø34)
- ⑦ Control wiring intake (knockout hole Ø27)
- ⑧ Drain outlet

3D110011



RZASG-MV1/MY1

Installation service space

The measure of these values is "mm".

(A) When there are obstacles on suction sides.

• No obstacle above

- ① Stand-alone installation
 - Obstacle on the suction side only

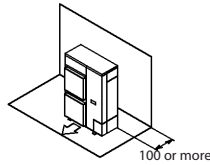

- Obstacle on both sides and suction side, too

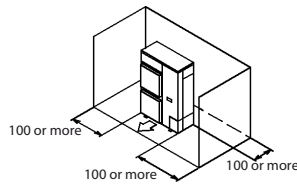

- ② Series installation (2 or more) (Note 1)
 - Obstacle on the suction side and both sides

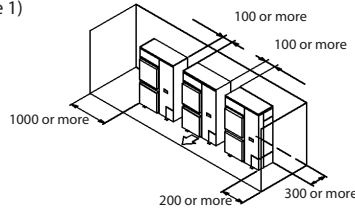

• Obstacle above, too.

- ① Stand-alone installation
 - Obstacle on the suction side, too

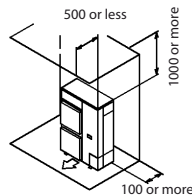

- Obstacle on both sides and suction side, too

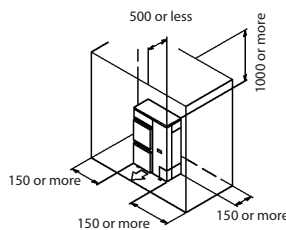

- ② Series installation (2 or more) (Note 1)
 - Obstacle on the suction side and both sides

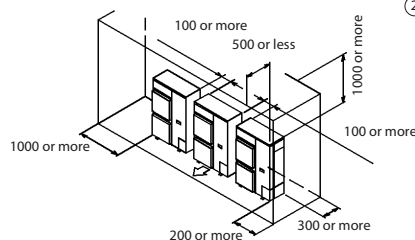

(B) When there are obstacles on discharge sides.

• No obstacle above

- ① Stand-alone installation
 - Obstacle on the discharge side only

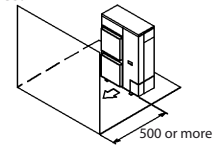

- ② Series installation (2 or more) (Note 1)
 - Obstacle on the suction side only

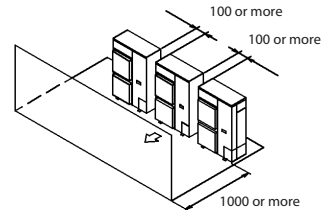

• Obstacle above, too.

- ① Stand-alone installation
 - Obstacle on the discharge side only, too

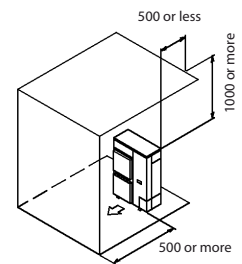

- ② Series installation (2 or more) (Note 1)
 - Obstacle on discharge side

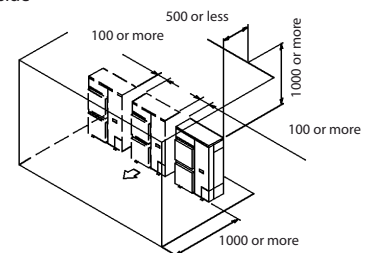

(C) When there are obstacles on both suction and discharge sides:

Pattern 1

When the obstacles on the discharge side is higher than the unit. (L > H)
(There is no limit for the height of obstructions on the suction side.)

• No obstacle above

- ① Stand-alone installation
 - No obstacle above

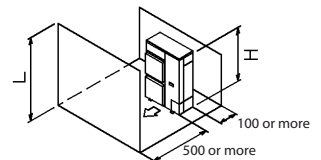

- ② Series installation (2 or more) (Note 1)
 - No obstacle above

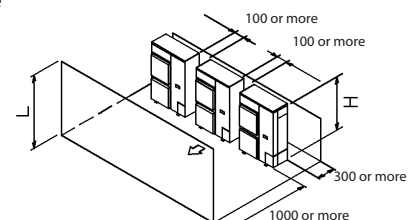

Detailed technical drawings

RZASG-MV1/MY1

• Obstacle above, too

- ① Stand-alone installation (Note 2)
 - When there are obstacles on suction, discharge and top sides.

The relations between H, A and L are as follows.

	L	A
$L \leq H$	$L \leq 1/2 H$ $1/2 H < L \leq H$	750 or more 1000 or more
$L > H$	Set the stand as : $L \leq H$ Refer to the column of $L \leq H$ for A	

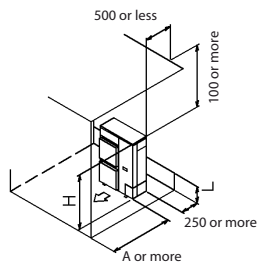

- ② Series installation (2 or more) (Note 1,2)
 - When there are obstacles on suction, discharge and top sides.

The relations between H, A and L are as follows.

	L	A
$L \leq H$	$L \leq 1/2 H$ $1/2 H < L \leq H$	1000 or more 1250 or more
$L > H$	Set the stand as : $L \leq H$ Refer to the column of $L \leq H$ for A	

Limit of series installation is 2 units.

Pattern 2

When the obstacle on the discharge side is lower than the unit ($L \leq H$) (There is no limit for the height of obstructions on the suction side.)

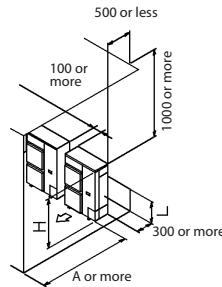

• No obstacle above

- ① Stand-alone installation
 - No obstacle above

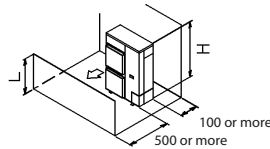

- ② Series installation (2 or more) (Note 1,2)
 - When there are obstacles on both suction and discharge sides.

The relations between H, A and L are as follows.

	L	A
$L \leq 1/2 H$	$L \leq 1/2 H$ $1/2 H < L \leq H$	250 or more 300 or more

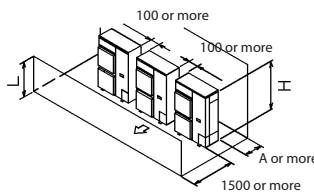

• Obstacle above

- ① Stand-alone installation (Note 2)
 - When there are obstacles on suction, discharge and top sides.

The relations between H, A and L are as follows.

	L	A
$L \leq H$	$L \leq 1/2 H$ $1/2 H < L \leq H$	100 or more 200 or more
$L > H$	Set the stand as : $L \leq H$ Refer to the column of $L \leq H$ for A	

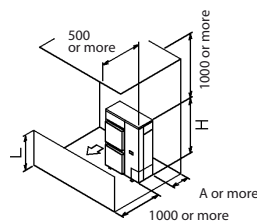

- ② Series installation (2 or more) (Note 1,2)
 - When there are obstacles on suction, discharge and top sides.

The relations between H, A and L are as follows.

	L	A
$L \leq H$	$L \leq 1/2 H$ $1/2 H < L \leq H$	250 or more 300 or more
$L > H$	Set the stand as : $L \leq H$ Refer to the column of $L \leq H$ for A	

Limit of series installation is 2 units.

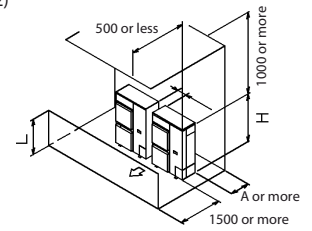

(D) Double-decker installation

- ① Obstacle on the discharge side. (1)
 - Do not exceed two levels for stacked installation.
 - Install a roof cover similar to A (field supply), as outdoor units with downward drainage are prone to dripping and freezing.
 - Install the upper-level outdoor unit so that its bottom plate is a sufficient height above the roof cover. This is to prevent the buildup of ice on the underside of the bottom plate.
- ② Obstacle on the suction side. (1)
 - Do not exceed two levels for stacked installation.
 - Install a roof cover similar to A (field supply), as outdoor units with downward drainage are prone to dripping and freezing.
 - Install the upper-level outdoor unit so that its bottom plate is a sufficient height above the roof cover. This is to prevent the buildup of ice on the underside of the bottom plate.

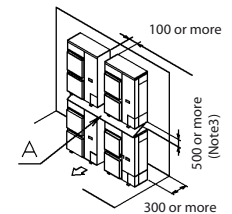
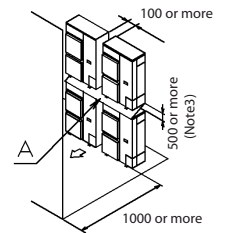

(E) Multiple rows of series installation (on the rooftop, etc.)

- ① One row of stand-alone installation

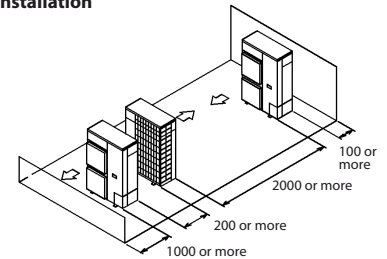

- ② Rows of series installation (2 or more)

The relations between H, A and L are as follows.

	L	A
$L \leq H$	$L \leq 1/2 H$ $1/2 H < L \leq H$	250 or more 300 or more
$L > H$	Can not be installed	

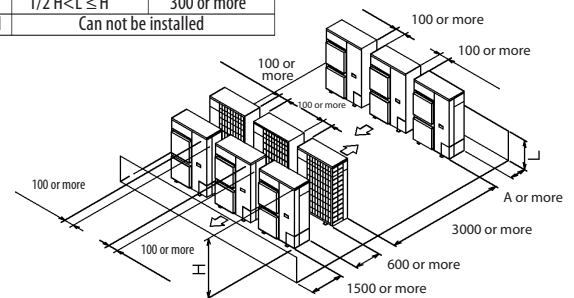

NOTES

- In case of the sideways piping, make a 100mm gap between the unit above.
- Close the bottom of the installation frame to prevent the discharged air from being bypassed.
- It is not necessary to install a roof cover if there is no danger of drainage dripping and freezing. In this case, the space between the upper and lower outdoor units should be at least 100mm. Close off the gap between the upper and lower units so there is no reintake of discharged air.



RZASG-MV1/MY1

To determine if adding additional refrigerant is necessary

if	Then
$(L1+L2+L3+L4+L5+L6+L7) \leq 30$ m (chargeless length)	You do not have to add additional refrigerant.
$(L1+L2+L3+L4+L5+L6+L7) > 30$ m (chargeless length)	You must add additional refrigerant. For future servicing, encircle the selected amount in the tables below.

INFORMATION

Piping length is the largest one way length of liquid piping.

To determine the additional refrigerant amount (R in kg) (in case of pair)

L1:	30~40 m	40~50 m
R:	0.35 kg	0.7 kg

To determine the additional refrigerant amount (R in kg) (in case of twin, triple and double twin)

1. Determine R1 and R2.

if	Then
$G1 > 30$ m	Use the table below to determine R1
$G1 \leq 30$ m (and $G1+G2 > 30$ m)	$R1 = 0.0$ kg. Use the table below to determine R2.

	Length (total length of liquid piping – 30 m)				
	0~10 m	10~20 m	20~30 m	30~40 m	40~45 m
R1:	0.35 kg	0.7 kg	1.05 kg ^(a)	1.4 kg ^(a)	
R2:	0.2 kg	0.4 kg	0.6 kg	0.8 kg ^(a)	1 kg ^(b)

a) Only for RZASG100~140.

b) Only for RZASG100+125.

2. Determine the additional refrigerant amount: $R = R1 + R2$.

Examples

Layout	Additional refrigerant amount (R)		
	Case: Twin, standard liquid pipe size		
	1.	G1	Total Ø9.5 => $G1 = 35$ m
		G2	Total Ø6.4 => $G2 = 7 + 5 = 12$ m
	2.		Case: $G1 > 30$ m
	R1	Length = $G1 - 30$ m = 5 m => $R1 = 0.35$ kg	
	R2	Length = $G2 = 12$ m => $R2 = 0.4$ kg	
3.	R	$R = R1 + R2 = 0.35 + 0.4 = 0.75$ kg	
	Case: Triple, standard liquid pipe size		
	1.	G1	Total Ø9.5 => $G1 = 5$ m
		G2	Total Ø6.4 => $G2 = 15 + 12 + 17 = 44$ m
	2.		Case: $G1 \leq 30$ m (and $G1 + G2 > 30$ m)
	R1	$R1 = 0.0$ kg	
	R2	Length = $G1 + G2 - 30$ m = $5 + 44 - 30 = 19$ m => $R2 = 0.4$ kg	
3.	R	$R = R1 + R2 = 0.0 + 0.4 = 0.4$ kg	



AZAS71-140MV1

Indoor	Outdoor	Power supply	Voltage range		MCA	TOCA	MFA	Compressor		OFM		IFM				
								MSC	RLA	kW	FLA	kW	FLA			
FCAG71AVEB	AZAS71M2V1B	50Hz~ 220- 240 V	Minimum: 198 V	Maximum: 264 V	17.4	-	20	-	15.4	0.094	0.9	0.054	0.4			
FBA71A2VEB	AZAS71M2V1B				17.5	-	20	-	15.4	0.094	0.9	0.070	0.5			
FAA71AUVEB	AZAS71M2V1B				17.4	-	20	-	15.4	0.094	0.9	0.048	0.4			
FCAG100AVEB	AZAS100M7V1B				21.5	-	25	-	19.0	0.200	1.0	0.117	0.7			
FBA100AVEB	AZAS100M7V1B				21.8	-	25	-	19.0	0.200	1.0	0.127	1.0			
FAA100AUVEB	AZAS100M7V1B				21.2	-	25	-	19.0	0.200	1.0	0.064	0.4			
FCAG125AVEB	AZAS125M7V1B				27.8	-	32	-	24.7	0.200	1.0	0.168	1.0			
FBA125A2VEB	AZAS125M7V1B				28.3	-	32	-	24.7	0.200	1.0	0.187	1.5			
					-	-	-	-	-	-	-	-	-	-	-	
FCAG140AVEB	AZAS140M7V1B				27.0	-	32	-	24.0	0.200	1.0	0.168	1.0			
FBA140A2VEB	AZAS140M7V1B				27.6	-	32	-	24.0	0.200	1.0	0.187	1.5			
FCAG100AVEB	AZAS100M7Y1B				3 N~50 Hz 380- 415 V	Minimum: 342 V	Maximum: 456 V	14.2	-	16	-	12.0	0.200	1.0	0.117	0.7
FBA100A2VEB	AZAS100M7Y1B							14.6	-	16	-	12.0	0.200	1.0	0.127	1.0
FAA100AUVEB	AZAS100M7Y1B							13.9	-	16	-	12.0	0.200	1.0	0.064	0.4
FCAG125AVEB	AZAS125M7Y1B	14.6	-	16				-	12.0	0.200	1.0	0.168	1.0			
FBA125A2VEB	AZAS125M7Y1B	15.1	-	16				-	12.0	0.200	1.0	0.187	1.5			
		-	-	-				-	-	-	-	-	-	-	-	
FCAG140AVEB	AZAS140M7Y1B	14.6	-	16				-	12.0	0.200	1.0	0.168	1.0			
FBA140A2VEB	AZAS125M7Y1B	15.1	-	16				-	12.0	0.200	1.0	0.187	1.5			

AZAS71-140MV1

3D110014A

AZAS-MV1/MY1

Symbols	Notes
<p>MCA Min. Circuit Amps. (A)</p> <p>TOCA Total Over-Current Amps. (A)</p> <p>MFA Max. Fuse Amps (See note 7) (A)</p> <p>MSC Max. current during the starting compressor. (A)</p> <p>RLA Rated Load Amps. (A)</p> <p>OFM Outdoor Fan Motor. (A)</p> <p>IFM Indoor Fan Motor.</p> <p>FLA Full Load Amps.</p> <p>kW Fan Motor Rated Output (kW)</p>	<p>1 RLA is based on the following indoor conditions: Cooling Indoor temperature 27.0°CDB/19.0°CWB Outdoor temperature 35.0°CDB Heating Indoor temperature 20.0°CDB Outdoor temperature 7.0°CDB/6.0°CWB.</p> <p>2 TOCA means the total value of each OC set.</p> <p>3 Voltage range Units are suitable for use on electrical systems where voltage supplied to unit terminals is not below or above listed range limits.</p> <p>4 Maximum allowable voltage variation between phases is 2% .</p> <p>5 MCA is the maximum input current. The capacity of the MFA must be greater than that of the MCA. Select the MFA according to the table.</p> <p>6 Select the wire size according to the MCA.</p> <p>7 MFA is used to select the circuit breaker and the ground fault circuit interrupter. (earth leakage circuit breaker)</p>

3D110014A.



AZAS71MV1

4 holes for anchor bolts
M12

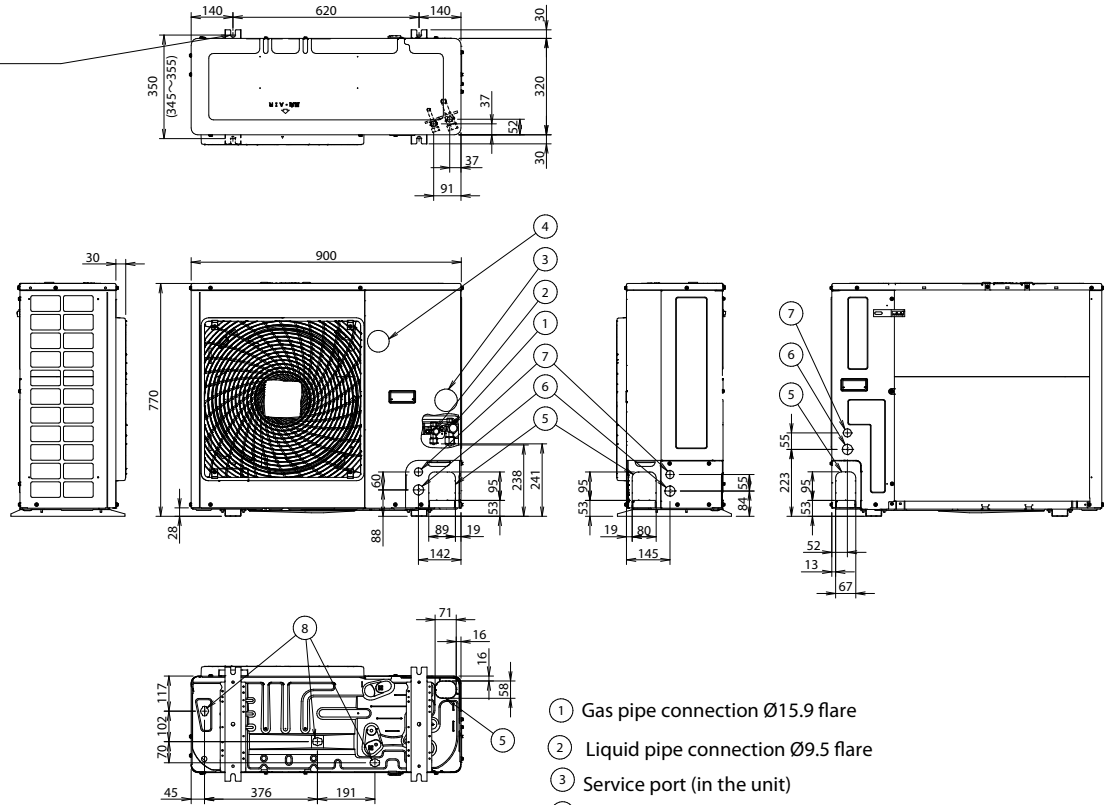

- ① Gas pipe connection $\text{\O}15.9$ flare
- ② Liquid pipe connection $\text{\O}9.5$ flare
- ③ Service port (in the unit)
- ④ Electronic connection and grounding terminal M5 (in the switch box)
- ⑤ Refrigerant piping intake
- ⑥ Power supply wiring intake (knockout hole $\text{\O}34$)
- ⑦ Control wiring intake (knockout hole $\text{\O}27$)
- ⑧ Drain outlet

3D110013



Detailed technical drawings

AZAS100-140MV1/MY1

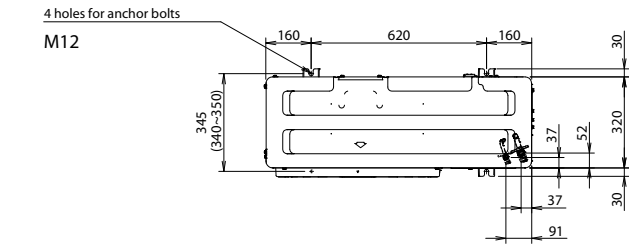

Model	AA	AB
RZAG71* / RZASG100-125* / AZAS100-125*	331	337
RZASG140* / AZAS140*	414	420

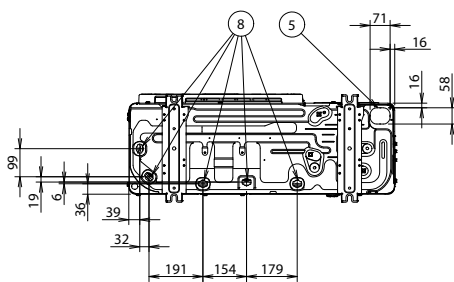
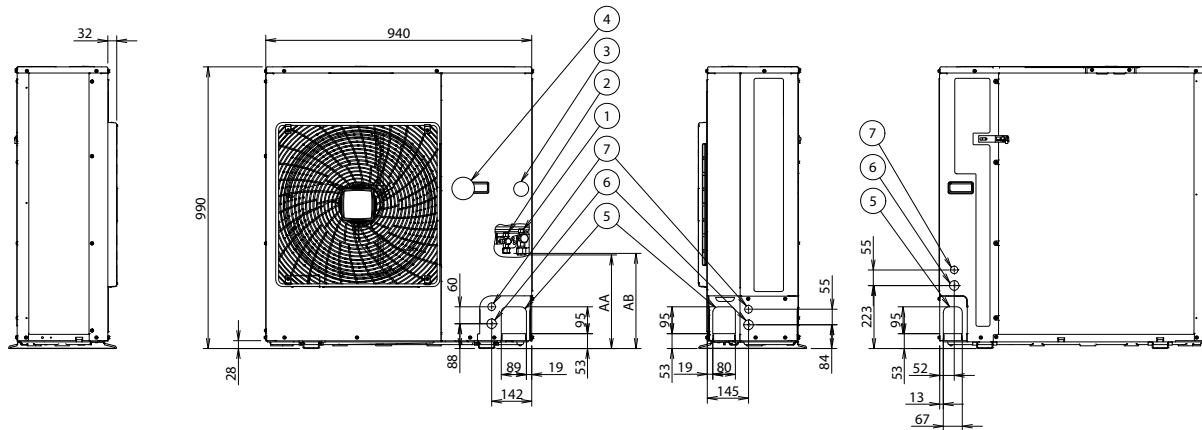

- ① Gas pipe connection Ø15.9 flare
- ② Liquid pipe connection Ø9.5 flare
- ③ Service port (in the unit)
- ④ Electronic connection and grounding terminal M5 (in the switch box)
- ⑤ Refrigerant piping intake
- ⑥ Power supply wiring intake (knockout hole Ø34)
- ⑦ Control wiring intake (knockout hole Ø27)
- ⑧ Drain outlet

3D110011



AZAS-MV1/MY1

Installation service space

The measure of these values is "mm".

(A) When there are obstacles on suction sides.

• No obstacle above

- ① Stand-alone installation
 - Obstacle on the suction side only

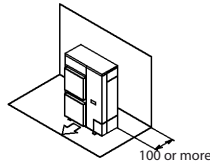

- Obstacle on both sides and suction side, too

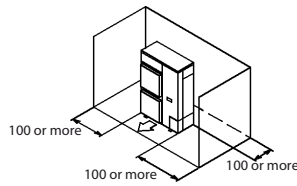

- ② Series installation (2 or more) (Note 1)
 - Obstacle on the suction side and both sides

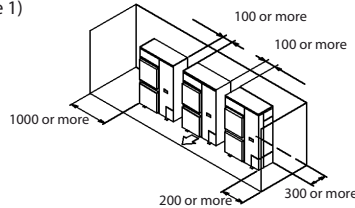

• Obstacle above, too.

- ① Stand-alone installation
 - Obstacle on the suction side, too

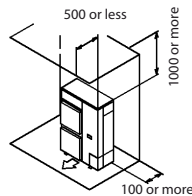

- Obstacle on both sides and suction side, too

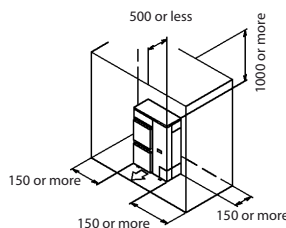

- ② Series installation (2 or more) (Note 1)
 - Obstacle on the suction side and both sides

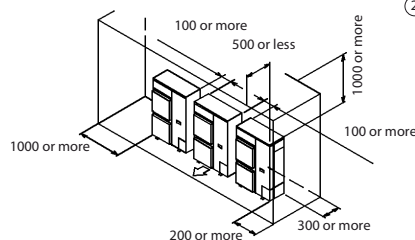

(B) When there are obstacles on discharge sides.

• No obstacle above

- ① Stand-alone installation
 - Obstacle on the discharge side only

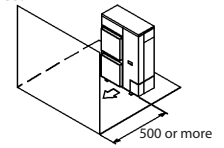

- ② Series installation (2 or more) (Note 1)
 - Obstacle on the suction side only

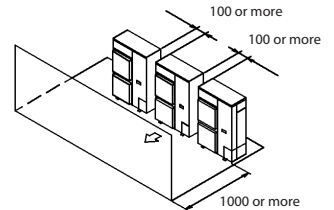

• Obstacle above, too.

- ① Stand-alone installation
 - Obstacle on the discharge side only, too

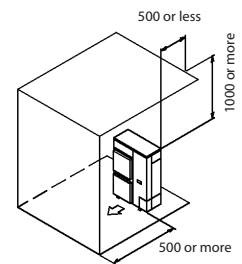

- ② Series installation (2 or more) (Note 1)
 - Obstacle on discharge side

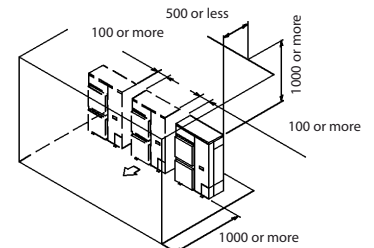

(C) When there are obstacles on both suction and discharge sides:

Pattern 1

When the obstacles on the discharge side is higher than the unit. (L > H)
(There is no limit for the height of obstructions on the suction side.)

• No obstacle above

- ① Stand-alone installation
 - No obstacle above

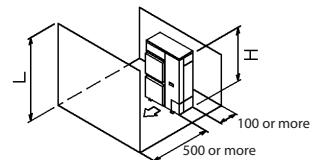

- ② Series installation (2 or more) (Note 1)
 - No obstacle above

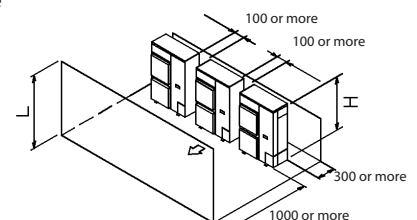

Detailed technical drawings

AZAS-MV1/MY1

• Obstacle above, too

- ① Stand-alone installation (Note 2)
 - When there are obstacles on suction, discharge and top sides.

The relations between H, A and L are as follows.

	L	A
$L \leq H$	$L \leq 1/2 H$ $1/2 H < L \leq H$	750 or more 1000 or more
$L > H$	Set the stand as: $L \leq H$ Refer to the column of $L \leq H$ for A	

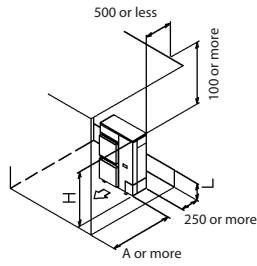

- ② Series installation (2 or more) (Note 1,2)
 - When there are obstacles on suction, discharge and top sides.

The relations between H, A and L are as follows.

	L	A
$L \leq H$	$L \leq 1/2 H$ $1/2 H < L \leq H$	1000 or more 1250 or more
$L > H$	Set the stand as: $L \leq H$ Refer to the column of $L \leq H$ for A	

Limit of series installation is 2 units.

Pattern 2

When the obstacle on the discharge side is lower than the unit ($L \leq H$) (There is no limit for the height of obstructions on the suction side.)

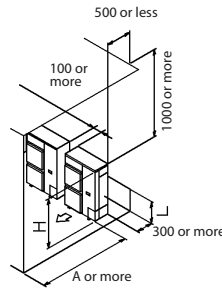

• No obstacle above

- ① Stand-alone installation
 - No obstacle above

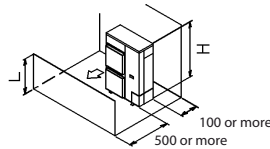

- ② Series installation (2 or more) (Note 1,2)
 - When there are obstacles on both suction and discharge sides.

The relations between H, A and L are as follows.

	L	A
$L \leq 1/2 H$	$L \leq 1/2 H$ $1/2 H < L \leq H$	250 or more 300 or more

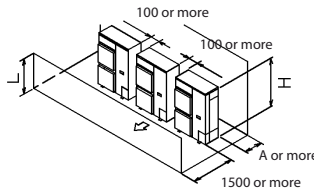

• Obstacle above

- ① Stand-alone installation (Note 2)
 - When there are obstacles on suction, discharge and top sides.

The relations between H, A and L are as follows.

	L	A
$L \leq H$	$L \leq 1/2 H$ $1/2 H < L \leq H$	100 or more 200 or more
$L > H$	Set the stand as: $L \leq H$ Refer to the column of $L \leq H$ for A	

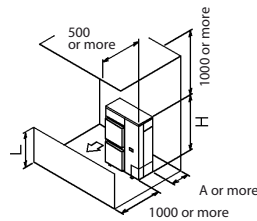

- ② Series installation (2 or more) (Note 1,2)
 - When there are obstacles on suction, discharge and top sides.

The relations between H, A and L are as follows.

	L	A
$L \leq H$	$L \leq 1/2 H$ $1/2 H < L \leq H$	250 or more 300 or more
$L > H$	Set the stand as: $L \leq H$ Refer to the column of $L \leq H$ for A	

Limit of series installation is 2 units.

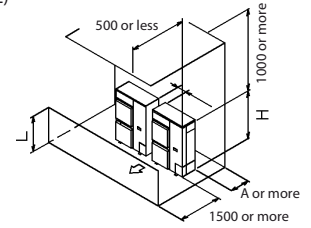

(D) Double-decker installation

- ① Obstacle on the discharge side. (1)
 - Do not exceed two levels for stacked installation.
 - Install a roof cover similar to A (field supply), as outdoor units with downward drainage are prone to dripping and freezing.
 - Install the upper-level outdoor unit so that its bottom plate is a sufficient height above the roof cover. This is to prevent the buildup of ice on the underside of the bottom plate.
- ② Obstacle on the suction side. (1)
 - Do not exceed two levels for stacked installation.
 - Install a roof cover similar to A (field supply), as outdoor units with downward drainage are prone to dripping and freezing.
 - Install the upper-level outdoor unit so that its bottom plate is a sufficient height above the roof cover. This is to prevent the buildup of ice on the underside of the bottom plate.

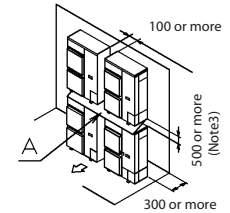
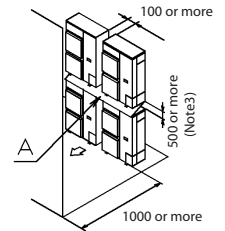

(E) Multiple rows of series installation (on the rooftop, etc.)

- ① One row of stand-alone installation

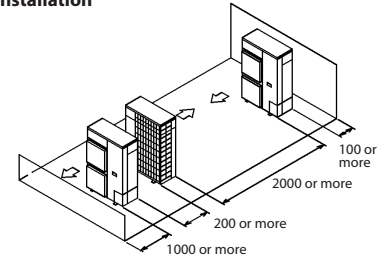

- ② Rows of series installation (2 or more)

The relations between H, A and L are as follows.

	L	A
$L \leq H$	$L \leq 1/2 H$ $1/2 H < L \leq H$	250 or more 300 or more
$L > H$	Can not be installed	

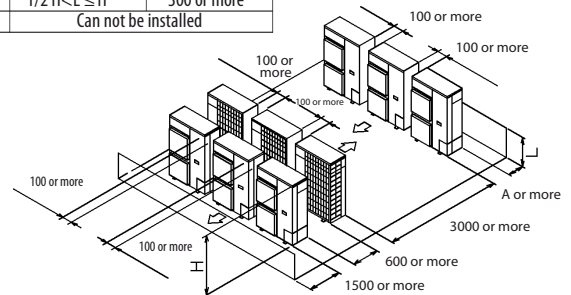

NOTES

- In case of the sideways piping, make a 100mm gap between the unit above.
- Close the bottom of the installation frame to prevent the discharged air from being bypassed.
- It is not necessary to install a roof cover if there is no danger of drainage dripping and freezing. In this case, the space between the upper and lower outdoor units should be at least 100mm. Close off the gap between the upper and lower units so there is no reintake of discharged air.



AZAS-MV1/MY1

To determine the complete recharge amount (kg)

Model	Length
	5~30m
AZAS71	2.45 Kg
AZAS100- 125	2.6 Kg
AZAS140	2.9 Kg

4P485929-1 – 2017.04

**RZQG-L9V1**

Unit combination restrictions		Power supply			COMP			OFM		IFM		
Indoor	Outdoor	1	2	3	MCA	MFA	RHz	RLA	kW	FLA	kW	FLA
2xFNA35A	RZQG71L9V1B	50	220-240V	Max.50Hz 264V Min. 50Hz 198V	17.2	20	-	15.6	0.094+0.094	0.4	2x0.034	2x0.3
2xFNA50A	RZQG100L9V1B				28.9	32	-	24.2	0.094+0.094	0.4+0.4	2x0.06	2x0.5
3xFNA35A	RZQG100L9V1B				28.8	32	-	24.2	0.094+0.094	0.4+0.4	3x0.034	3x0.3
2xFNA60A	RZQG125L9V1B				29	32	-	24.2	0.094+0.094	0.4+0.4	2x0.06	2x0.5
3xFNA50A	RZQG125L9V1B				29.5	32	-	24.2	0.094+0.094	0.4+0.4	3x0.06	3x0.5
4xFNA35A	RZQG125L9V1B				29.2	32	-	24.2	0.094+0.094	0.4+0.4	4x0.034	4x0.3
3xFNA50A	RZQG140L9V1B				29.5	32	-	24.2	0.094+0.094	0.4+0.4	3x0.06	3x0.5

Symbols	Notes
1 - HZ 2 - Voltage 3 - Voltage range MCA Minimum Circuit Ampere (A) MFA Maximum Fuse Ampere (A) RLA Rared Load Amps [A] OFM Outdoor Fan Motor IFM Indoor Fan Motor FLA Full Load Ampere (A) kW Fan motor rated output [kW] RHz Rated operating frequency [Hz] COMP Compressor	1 The RLA is based on the following conditions. Indoor temperature 27° CDB / 19° CWB. Outdoor temperature 35° CDB. 2 Select the wire size according to the MCA. 3 The maximum allowable voltage is unbalanced between phases is 2%. 4 Use a circuit breaker instead of a fuse.

RZQG140L9V1

3D096315C

RZQG71-125L9V1

Unit combination restrictions		Power supply			COMP			OFM		IFM		
Indoor	Outdoor	1	2	3	MCA	MFA	RHz	RLA	kW	FLA	FLA	FLA
FBA71A	RZQG71L9V1B	50	220-400V	MAX. 50Hz 264V Min. 50Hz 198V	16,4	20	51	15,6	0,094	0,4	0,07	0,5
2xFBA35A	RZQG71L9V1B				17,1	20	-	15,6	0,094	0,4	2x0.089	2x0.6
FBA1 00A	RZQG100L9V1B				28,9	32	49	24,2	0,094+ 0,094	0,4+ 0,4	0,127	1,0
2xFBA50A	RZQG100L9V1B				29,1	32	-	24,2	0,094+ 0,094	0,4+ 0,4	2x0.089	2x0.6
3xFBA35A	RZQG100L9V1B				29,7	32	-	24,2	0,094+ 0,094	0,4+ 0,4	3x0.089	3x0.6
FBA125A	RZQG1 25L9V1B				29,5	32	64	24,2	0,094+ 0,094	0,4+ 0,4	0,187	1,5
2xFBA60A	RZQG1 25L9V1B				29	32	-	24,2	0,094+ 0,094	0,4+ 0,4	2x0.070	2x0.5
3xFBA50A	RZQG1 25L9V1				29,8	32	-	24,2	0,094+ 0,094	0,4+ 0,4	3x0.089	3x0.6

Symbols	Notes
1 - HZ 2 - Voltage 3 - Voltage range MCA Minimum Circuit Ampere (A) MFA Maximum Fuse Ampere (A) RLA Rared Load Amps [A] OFM Outdoor Fan Motor IFM Indoor Fan Motor FLA Full Load Ampere (A) kW Fan motor rated output [kW] RHz Rated operating frequency [Hz] COMP Compressor	1 The RLA is based on the following conditions. Indoor temperature 27° CDB / 19° CWB. Outdoor temperature 35° CDB. 2 Select the wire size according to the MCA. 3 The maximum allowable voltage is unbalanced between phases is 2%. 4 Use a circuit breaker instead of a fuse.

RZQG71-125L9V1

30094863B



RZQG125-140L9V1

Unit combination restrictions		Power supply			COMP			OFM		IFM				
Indoor	Outdoor	1	2	3	MCA	MFA	RHz	RLA	kW	FLA	kW	FLA		
4xFBA35A	RZQG125L9V1B	50	220 - 240V	MAX. 50Hz 264V MIN. 50Hz 198V	30.4	32	-	24.2	0.094+0.094	0.4+0.4	4x0.089	4x0.6		
FBA140A	RZQG140L9V1B				29.5	32	68	24.2	0.094+0.094	0.4+0.4	0,187	1,5		
2xFBA71A	RZQG140L9V1B				29	32	-	24.2	0.094+0.094	0.4+0.4	2x0.07	2x0.5		
3xFBA50A	RZQG140L9V1B				29.8	32	-	24.2	0.094+0.094	0.4+0.4	3x0.089	3x0.6		
4xFBA35A	RZQG140L9V1B				30.4	32	-	24.2	0.094+0.094	0.4+0.4	4x0.089	4x0.6		

Symbols	Notes
1 - Hz	<p>1 The RLA is based on the following conditions. Indoor temperature 27°C CDB / 19°C CWB. Outdoor temperature 35°C CDB.</p> <p>2 Select the wire size according to the MCA.</p> <p>3 The maximum allowable voltage is unbalanced between phases is 2%.</p> <p>4 Use a circuit breaker instead of a fuse.</p>
2 - Voltage	
3 - Voltage range	
MCA Minimum Circuit Ampere (A)	
MFA Maximum Fuse Ampere (A)	
RLA Rared Load Amps [A]	
OFM Outdoor Fan Motor	
IFM Indoor Fan Motor	
FLA Full Load Ampere (A)	
kW Fan motor rated output [kW]	
RHz Rated operating frequency [Hz]	
COMP Compressor	

RZQG125-140L9V1

3D094863B

RZQG125-140L9V1

Indoor	Outdoor	Power supply	Voltage range	Compressor			OFM		IFM			
				MCA	TOCA	MFA	MSC	RLA	kW	FLA	kW	FLA
FCAHG71G	x2	1~50Hz 220-240V	Minimum: 198V Maximum: 264V	28.8	-	32	-	24.2	0.094+0.094	0.4+0.4	0,091x2	0,5x2
FCAHG140G				29.3	-	32	-	24.2	0.094+0.094	0.4+0.4	0,244	1,4
FCAG35A	x4			29.0	-	32	-	24.2	0.094+0.094	0.4+0.4	0,044x4	0,3x4
FCAG50A	x3			28.6	-	32	-	24.2	0.094+0.094	0.4+0.4	0,039x3	0,3x3
FCAG71A	x2			28.5	-	32	-	24.2	0.094+0.094	0.4+0.4	0,054x2	0,4x2
FCAG140A				28.8	-	32	-	24.2	0.094+0.094	0.4+0.4	0,168	1,0
FFA35A	x4			29.5	-	32	-	24.2	0.094+0.094	0.4+0.4	0,050x4	0,4x4
FFA50A	x3			29.0	-	32	-	24.2	0.094+0.094	0.4+0.4	0,050x3	0,4x3
FBA35A	x4			30.5	-	32	-	24.2	0.094+0.094	0.4+0.4	0,089x4	0,6 x4
FBA50A	x3			29.8	-	32	-	24.2	0.094+0.094	0.4+0.4	0,089x3	0,6x3
FBA71A	x2			28.8	-	32	-	24.2	0.094+0.094	0.4+0.4	0,070x2	0,5x2
FBA140A				29.4	-	32	-	24.2	0.094+0.094	0.4+0.4	0,187	1,5
FHA35A	x4			30.5	-	32	-	24.2	0.094+0.094	0.4+0.4	0,060x4	0,6x4
FHA50A	x3			29.8	-	32	-	24.2	0.094+0.094	0.4+0.4	0,060x3	0,6x3
FHA71A	x2			29.5	-	32	-	24.2	0.094+0.094	0.4+0.4	0,091x2	0,8x2
FHA140A				29.8	-	32	-	24.2	0.094+0.094	0.4+0.4	0,150	1,8
FUA71A	x2			29.8	-	32	-	24.2	0.094+0.094	0.4+0.4	0,046x2	0,9x2
FAA71A	x2			28.5	-	32	-	24.2	0.094+0.094	0.4+0.4	0,048x2	0,4x2
FVA140A				29.3	-	32	-	24.2	0.094+0.094	0.4+0.4	0,276	1,4
FDXM35F3	x4			29.0	-	32	-	24.2	0.094+0.094	0.4+0.4	0,034x4	0,3x4
FDXM50F3	x3	29.4	-	32	-	24.2	0.094+0.094	0.4+0.4	0,060x3	0,5x3		
FCAHG71G	x2	1~50Hz 220-240V	Minimum: 198V Maximum: 264V	28.8	-	32	-	24.2	0.094+0.094	0.4+0.4	0,091x2	0,2x2
FCAHG140G				29.3	-	32	-	24.2	0.094+0.094	0.4+0.4	0,244	1,4
FCAG35A	x4			29.0	-	32	-	24.2	0.094+0.094	0.4+0.4	0,044x4	0,3x4
FCAG50A	x3			28.6	-	32	-	24.2	0.094+0.094	0.4+0.4	0,039x3	0,3x3
FCAG71A	x2			28.5	-	32	-	24.2	0.094+0.094	0.4+0.4	0,054x2	0,4x2
FCAG140A				28.8	-	32	-	24.2	0.094+0.094	0.4+0.4	0,168	1,0
FFA35A	x4			29.5	-	32	-	24.2	0.094+0.094	0.4+0.4	0,050x4	0,4x4
FFA50A	x3			29.0	-	32	-	24.2	0.094+0.094	0.4+0.4	0,050x3	0,4x3
FBA35A	x4			30.5	-	32	-	24.2	0.094+0.094	0.4+0.4	0,089x4	0,6x4
FBA50A	x3			29.8	-	32	-	24.2	0.094+0.094	0.4+0.4	0,089x3	0,6x3
FBA71A	x2			28.8	-	32	-	24.2	0.094+0.094	0.4+0.4	0,070x2	0,5x2
FBA140A				29.4	-	32	-	24.2	0.094+0.094	0.4+0.4	0,187	1,5
FHA35A	x4			30.5	-	32	-	24.2	0.094+0.094	0.4+0.4	0,060x4	0,6x4
FHA50A	x3			29.8	-	32	-	24.2	0.094+0.094	0.4+0.4	0,060x3	0,6x3
FHA71A	x2			29.5	-	32	-	24.2	0.094+0.094	0.4+0.4	0,091x2	0,8x2
FHA140A				29.8	-	32	-	24.2	0.094+0.094	0.4+0.4	0,150	1,8
FUA71A	x2			29.8	-	32	-	24.2	0.094+0.094	0.4+0.4	0,046x2	0,9x2
FAA71A	x2			28.5	-	32	-	24.2	0.094+0.094	0.4+0.4	0,048x2	0,4x2
FVA140A				29.3	-	32	-	24.2	0.094+0.094	0.4+0.4	0,276	1,4
FDXM35F3	x4			29.0	-	32	-	24.2	0.094+0.094	0.4+0.4	0,034x4	0,3x4
FDXM50F3	x3	29.4	-	32	-	24.2	0.094+0.094	0.4+0.4	0,060x3	0,5x3		

Symbols	Notes
MCA Min. Circuit Amps. (A)	<p>1 RLA is based on the following indoor conditions: Power supply: 50Hz 400V Cooling Indoor temperature 27.0°CDB/19.0°CWB Outdoor temperature 35.0°CDB Heating Indoor temperature 20.0°CDB Outdoor temperature 7.0°CDB/6.0°CWB.</p> <p>2 TOCA means the total value of each OC set.</p> <p>3 Voltage range Units are suitable for use on electrical systems where voltage supplied to unit terminals is not below or above listed range limits.</p> <p>4 Maximum allowable voltage variation between phases is 2% .</p> <p>5 MCA represents maximum input current, MFA represents capacity which may accept MCA. (next lower standard fuse rating, min.15A).</p> <p>6 Select wire size based on the larger value of MCA or TOCA.</p> <p>7 MFA is used to select the circuit breaker and the ground fault circuit interrupter. (earth leakage circuit breaker)</p>
TOCA Total Over-Current Amps. (A)	
MFA Max. Fuse Amps (See note 7) (A)	
MSC Max. current during the starting compressor. (A)	
RLA Rated Load Amps. (A)	
OFM Outdoor Fan Motor. (A)	
IFM Indoor Fan Motor.	
FLA Full Load Amps.	
kW Fan Motor Rated Output (kW)	

RZQG125-140L9V1

3D098291



Detailed technical drawings

RZQG125-140L9V1

Indoor	Outdoor	Hz	Voltage	MCA	TOCA	MFA	Compressor		OFM		IFM	
							MSC	RLA	kW	FLA	kW	FLA
FCAHG125G		SOHz 220-240V	Min. 198V Max.264V	29.3	-	32	-	24.2	0.094+0.094	0.4+0.4	0.244	1.4
FCAG35A	x4			29.0	-	32	-	24.2	0.094+0.094	0.4+0.4	0.044x4	0.3x4
FCAG50A	x3			28.6	-	32	-	24.2	0.094+0.094	0.4+0.4	0.039x3	0.3x3
FCAG60A	x2			28.3	-	32	-	24.2	0.094+0.094	0.4+0.4	0.044x2	0.3x2
FCAG125A				28.8	-	32	-	24.2	0.094+0.094	0.4+0.4	0.168	1.0
FFA35A	x4			29.5	-	32	-	24.2	0.094+0.094	0.4+0.4	0.050x4	0.4x4
FFA50A	x3			29.0	-	32	-	24.2	0.094+0.094	0.4+0.4	0.050x3	0.4x3
FFA60A	x2			29.0	-	32	-	24.2	0.094+0.094	0.4+0.4	0.050x2	0.6x2
FDXM35F3	x4			29.0	-	32	-	24.2	0.094+0.094	0.4+0.4	0.034x4	0.3x4
FDXM50F3	x3			29.4	-	32	-	24.2	0.094+0.094	0.4+0.4	0.06x3	0.5x3
FDXM60F3	x2			28.8	-	32	-	24.2	0.094+0.094	0.4+0.4	0.060x2	0.5x2
FBA35A	x4			33.5	-	40	-	24.2	0.094+0.094	0.4+0.4	0.140x4	1.2x4
FBA50A	x3			32.0	-	40	-	24.2	0.094+0.094	0.4+0.4	0.140x3	1.2x3
FBA60A	x2			30.3	-	32	-	24.2	0.094+0.094	0.4+0.4	0.350x2	1.1x2
FBA125A				30.1	-	32	-	24.2	0.094+0.094	0.4+0.4	0.350	2.1
FHA35A	x4			30.5	-	32	-	24.2	0.094+0.094	0.4+0.4	0.062x4	0.6x4
FHA50A	x3			29.8	-	32	-	24.2	0.094+0.094	0.4+0.4	0.062x3	0.6x3
FHA60A	x2			29.0	-	32	-	24.2	0.094+0.094	0.4+0.4	0.062x2	0.6x2
FUA125A				28.8	-	32	-	24.2	0.094+0.094	0.4+0.4	0.289	1.0
FDA125A				30.1	-	32	-	24.2	0.094+0.094	0.4+0.4	0.350	2.1
FVA125A				29.0	-	32	-	24.2	0.094+0.094	0.4+0.4	0.238	1.2
FHA35A	x4			30.5	-	32	-	24.2	0.094+0.094	0.4+0.4	0.060x4	0.6x4
FHA50A	x3			29.8	-	32	-	24.2	0.094+0.094	0.4+0.4	0.060x3	0.6x3
FHA60A	x2			29.0	-	32	-	24.2	0.094+0.094	0.4+0.4	0.091x2	0.6x2
FUA125A				29.4	-	32	-	24.2	0.094+0.094	0.4+0.4	0.150	1.5
FUA125A				29.3	-	32	-	24.2	0.094+0.094	0.4+0.4	0.106	1.4
FCAHG71G	x2			28.8	-	32	-	24.2	0.094+0.094	0.4+0.4	0.091x2	0.5x2
FCAHG140G				29.3	-	32	-	24.2	0.094+0.094	0.4+0.4	0.244	1.4
FCAG35A	x4			29.0	-	32	-	24.2	0.094+0.094	0.4+0.4	0.044x4	0.3x4
FCAG50A	x3			28.6	-	32	-	24.2	0.094+0.094	0.4+0.4	0.039x3	0.3x3
FCAG71A	x2	28.5	-	32	-	24.2	0.094+0.094	0.4+0.4	0.054x2	0.4x2		
FCAG140A		28.8	-	32	-	24.2	0.094+0.094	0.4+0.4	0.168	1.0		
FFA35A	x4	29.5	-	32	-	24.2	0.094+0.094	0.4+0.4	0.050x4	0.4x4		
FFA50A	x3	29.0	-	32	-	24.2	0.094+0.094	0.4+0.4	0.050x3	0.4x3		
FDXM35F3	x4	29.0	-	32	-	24.2	0.094+0.094	0.4+0.4	0.034x4	0.3x4		
FDXM50F3	x3	29.4	-	33	-	24.2	0.094+0.094	0.4+0.4	0.06x3	0.5x3		
FBA35A	x4	33.5	-	40	-	24.2	0.094+0.094	0.4+0.4	0.140x4	1.2x4		
FBA50A	x3	32.0	-	40	-	24.2	0.094+0.094	0.4+0.4	0.140x3	1.2x3		
FBA71A	x2	30.3	-	32	-	24.2	0.094+0.094	0.4+0.4	0.350x2	1.1x2		
FBA140A		30.1	-	32	-	24.2	0.094+0.094	0.4+0.4	0.350	2.1		
FAA71A	x2	28.5	-	32	-	24.2	0.094+0.094	0.4+0.4	0.048x2	0.4x2		
FVA140A		29.3	-	32	-	24.2	0.094+0.094	0.4+0.4	0.276	1.4		
FHA35A	x4	30.5	-	32	-	24.2	0.094+0.094	0.4+0.4	0.060 X 4	0.6x4		
FHA50A	x3	29.8	-	32	-	24.2	0.094+0.094	0.4+0.4	0.060 X 3	0.6x3		
FHA71A	x2	29.5	-	32	-	24.2	0.094+0.094	0.4+0.4	0.091 X 2	0.8x2		
FHA140A		29.8	-	32	-	24.2	0.094+0.094	0.4+0.4	0.150	1.8		
FUA71A	x2	29.8	-	32	-	24.2	0.094+0.094	0.4+0.4	0.046 X 2	0.9x2		

Symbols	Notes
<p>MCA Min. Circuit Amps. (A)</p> <p>TOCA Total Over-Current Amps. (A)</p> <p>MFA Max. Fuse Amps (See note 7) (A)</p> <p>MSC Max. current during the starting compressor. (A)</p> <p>RLA Rated Load Amps. (A)</p> <p>OFM Outdoor Fan Motor. (A)</p> <p>IFM Indoor Fan Motor.</p> <p>FLA Full Load Amps.</p> <p>kW Fan Motor Rated Output (kW)</p>	<p>1 RLA is based on the following indoor conditions: Power supply: 50Hz 400V Cooling Indoor temperature 27.0°CDB/19.0°CWB Outdoor temperature 35.0°CDB Heating Indoor temperature 20.0°CDB Outdoor temperature 7.0°CDB/6.0°CWB.</p> <p>2 TOCA means the total value of each OC set.</p> <p>3 Voltage range Units are suitable for use on electrical systems where voltage supplied to unit terminals is not below or above listed range limits.</p> <p>4 Maximum allowable voltage variation between phases is 2% .</p> <p>5 MCA represents maximum input current, MFA represents capacity which may accept MCA. (next lower standard fuse rating, min.15A).</p> <p>6 Select wire size based on the larger value of MCA or TOCA.</p> <p>7 MFA is used to select the circuit breaker and the ground fault circuit interrupter. (earth leakage circuit breaker)</p>

(1) EWAQ-CWN: Version without pump. (2) EWAQ-CWP: Version with pump.

RZQG125-140L9V1

3D090680

RZQG140L9V1

Unit combination restrictions		Power supply			COMP			OFM		IFM		
Indoor	Outdoor	1	2	3	MCA	MFA	RHz	RLA	kW	FLA	kW	FLA
4X FNA35A	RZQG140L9V1B	50	220- 240	Max. 50Hz 264V Min. 50Hz 198V	29.2	32	-	24.2	0.094+ 0.094	0.4+0.4	4x0.034	4x0.3

Symbols	Notes
<p>1 - HZ</p> <p>2 - Voltage</p> <p>3 - Voltage range</p> <p>MCA Minimum Circuit Ampere (A)</p> <p>MFA Maximum Fuse Ampere (A)</p> <p>RLA Rared Load Amps [A]</p> <p>OFM Outdoor Fan Motor</p> <p>IFM Indoor Fan Motor</p> <p>FLA Full Load Ampere (A)</p> <p>kW Fan motor rated output [kW]</p> <p>RHz Rated operating frequency [Hz]</p> <p>COMP Compressor</p>	<p>1 The RLA is based on the following conditions. Indoor temperature 27° CDB / 19° CWB. Outdoor temperature 35° CDB.</p> <p>2 Select the wire size according to the MCA.</p> <p>3 The maximum allowable voltage is unbalanced between phases is 2%.</p> <p>4 Use a circuit breaker instead of a fuse.</p>

RZQG140L9V1

3D096315C



RZQG71-100L8Y1

Indoor	Outdoor	Phase ~ Hz Power supply	Voltage range	MCA	TOCA	MFA	Comp		OFM		IFM			
							MSC	RLA	kW	FLA	kW	FLA		
FCAG71A		3N ~ 50Hz 380-415V	Min. 342V Max. 456V	11,5	-	16	-	9,6	0,094	0,4	0,048	0,4		
FCAHG71G				11,6	-	16	-	9,6	0,094	0,4	0,091	0,5		
FCAG35A	x2			11,8	-	16	-	9,6	0,094	0,4	0,044x2	0,3x2		
FCAG71A				11,5	-	16	-	9,6	0,094	0,4	0,054	0,4		
FFA35A	x2			12,0	-	16	-	9,6	0,094	0,4	0,05x2	0,4x2		
FDXM35F3	x2			11,8	-	16	-	9,6	0,094	0,4	0,034x2	0,3x2		
FBA35A	x2			14,0	-	16	-	9,6	0,094	0,4	0,140x2	1,2x2		
FBA71A				12,4	-	16	-	9,6	0,094	0,4	0,350	1,1		
FAA71A				11,5	-	16	-	9,6	0,094	0,4	0,048	0,4		
FVA71A				11,8	-	16	-	9,6	0,094	0,4	0,117	0,6		
FHA35A	x2			12,5	-	16	-	9,6	0,094	0,4	0,060x2	0,6x2		
FHA71A				12,0	-	16	-	9,6	0,094	0,4	0,091	0,8		
FUA71A				12,1	-	16	-	9,6	0,094	0,4	0,046	0,9		
FCAG100A				3N ~ 50Hz 380-415V	Min. 342V Max. 456V	17,8	-	20	-	14,2	0,094+0,094	0,4+0,4	0,106	1,0
FCAHG100G						18,1	-	20	-	14,2	0,094+0,094	0,4+0,4	0,221	1,3
FCAG35A	x3					17,6	-	20	-	14,2	0,094+0,094	0,4+0,4	0,044x3	0,3x3
FCAG50A	x2					17,3	-	20	-	14,2	0,094+0,094	0,4+0,4	0,039x2	0,3x2
FCAG100A						7,4	-	20	-	14,2	0,094+0,094	0,4+0,4	0,117	0,7
FFA35A	x3					18,0	-	20	-	14,2	0,094+0,094	0,4+0,4	0,05x3	0,4x3
FFA50A	x2					17,5	-	20	-	14,2	0,094+0,094	0,4+0,4	0,05x2	0,4x2
FDXM35F3	x3					17,6	-	17,6	-	14,2	0,094+0,094	0,4+0,4	0,034x3	0,3x3
FDXM50F3	x2	17,8	-			20	-	14,2	0,094+0,094	0,4+0,4	0,06x2	0,5x2		
FBA35A	x3	21,0	-			25	-	14,2	0,094+0,094	0,4+0,4	0,140x3	1,2x3		
FBA50A	x2	19,5	-			20	-	14,2	0,094+0,094	0,4+0,4	0,140x2	1,2x2		
FBA100A		18,5	-			20	-	14,2	0,094+0,094	0,4+0,4	0,350	1,6		
FAA100A		17,0	-			20	-	14,2	0,094+0,094	0,4+0,4	0,064	0,4		
FVA100A		18,0	-			20	-	14,2	0,094+0,094	0,4+0,4	0,238	1,2		
FHA35A	x3	18,8	-			20	-	14,2	0,094+0,094	0,4+0,4	0,060x3	0,6x3		
FHA50A	x2	18,0	-			20	-	14,2	0,094+0,094	0,4+0,4	0,060x2	0,6x2		
FHA100A		18,1	-			20	-	14,2	0,094+0,094	0,4+0,4	0,150	1,3		
FUA100A		18,1	-			20	-	14,2	0,094+0,094	0,4+0,4	0,106	1,3		

Symbols	Notes
<p>MCA Min. Circuit Amps. (A) TOCA Total Over-Current Amps. (A) MFA Max. Fuse Amps (See note 7) (A) MSC Max. current during the starting compressor. (A) RLA Rated Load Amps. (A) OFM Outdoor Fan Motor. (A) IFM Indoor Fan Motor. FLA Full Load Amps. kW Fan Motor Rated Output (kW)</p>	<p>1 RLA is based on the following indoor conditions: Cooling Indoor temperature 27.0°CDB/19.0°CWB Outdoor temperature 35.0°CDB 2 Voltage range The units are suitable for use with electrical systems in which the voltage supplied to the unit terminals is not below or above the listed range limits. 3 Maximum allowable voltage variation between phases is 2% . 4 MCA represents maximum input current, MFA represents capacity which may accept MCA. 5 Select the wire size according to the MCA..</p>

3D077810B

RZQG71-100L8Y1

Unit combination restrictions		Power supply			COMP		OFM		IFM			
Indoor	Outdoor	1	2	3	MCA	MFA	RHz	RLA	kW	FLA	kW	FLA
3xFBA60A	RZQ200C7Y1B	3N~ 50Hz	400V	MAX. 50Hz	11.8	16	-	9.6	0.094	0.4	0.07	0.5
4xFBA50A	RZQ200C7Y1B			415V	12	16	-	9.6	0.094	0.4	2x0.089	2x0.6
2xFBA125A	RZQ250C7Y1B			Min. 50Hz	17.9	20	-	14.2	0.094+ 0.094	0.4+ 0.4	0.127	1.0
4xFBA60A	RZQ250C7Y1B			380V	18.1	20	-	14.2	0.094+ 0.094	0.4+ 0.4	2x0.089	2x0.6

Symbols	Notes
<p>1 - HZ 2 - Voltage 3 - Voltage range MCA Minimum Circuit Ampere (A) MFA Maximum Fuse Ampere (A) RLA Rared Load Amps [A] OFM Outdoor Fan Motor IFM Indoor Fan Motor FLA Full Load Ampere (A) kW Fan motor rated output [kW] RHz Rated operating frequency [Hz] COMP Compressor</p>	<p>1. The RLA is based on the following conditions. Indoor temperature 27° CDB / 19° CWB. Outdoor temperature 35° CDB. 2. Select the wire size according to the MCA. 3. The maximum allowable voltage is unbalanced between phases is 2%. 4. Use a circuit breaker instead of a fuse.</p>

RZQG71-100L8Y1

3D094863B



Detailed technical drawings

RZQG71-100L8Y1

Unit combination restrictions		Power supply			COMP			OFM		IFM		
Indoor	Outdoor	1	2	3	MCA	MFA	RHz	RLA	kW	FLA	FLA	FLA
2xFNA35A	RZQG71L81B	3N~50Hz	380-400V	MAX. 50Hz 456V	11,9	16	-	9,6	0,094	0,4	2x0.034	2x0.3
2xFNA50A	RZQG100L8Y1B			Min. 50Hz 342V	17,9	20	-	14,2	0,094+ 0,094	0,4+ 0,4	2x0.06	2x0.5

Symbols	Notes
1 - Hz 2 - Voltage 3 - Voltage range MCA Minimum Circuit Ampere (A) MFA Maximum Fuse Ampere (A) RLA Rared Load Amps [A] OFM Outdoor Fan Motor IFM Indoor Fan Motor FLA Full Load Ampere (A) kW Fan motor rated output [kW] RHz Rated operating frequency [Hz] COMP Compressor	<p>1 The RLA is based on the following conditions. Indoor temperature 27° CDB / 19° CWB. Outdoor temperature 35° CDB.</p> <p>2 Select the wire size according to the MCA.</p> <p>3 The maximum allowable voltage is unbalanced between phases is 2%.</p> <p>4 Use a circuit breaker instead of a fuse.</p>

RZQG71-100L8Y1

3D096315C

RZQG71-100L8Y1

Indoor	Outdoor	Power supply	Voltage range	Compressor					OFM		IFM			
				MCA	TOCA	MFA	MSC	RLA	kW	FLA	kW	FLA		
FCAHG100G	RZQG71L8Y1B	3N~50Hz 380-415V	Minimum: 342V Maximum: 456V	12,6	-	16	-	9,6	0,094	0,4	0,221	1,3		
FCAG35A	x3 RZQG71L8Y1B			12,1	-	16	-	9,6	0,094	0,4	0,044x3	0,3x3		
FCAG50A	x2 RZQG71L8Y1B			11,8	-	16	-	9,6	0,094	0,4	0,039x2	0,3x2		
FCAG100A	RZQG71L8Y1B			11,9	-	16	-	9,6	0,094	0,4	0,117	0,7		
FFA35A	x3 RZQG71L8Y1B			12,5	-	16	-	9,6	0,094	0,4	0,050x3	0,4x3		
FFA50A	x2 RZQG71L8Y1B			12,0	-	16	-	9,6	0,094	0,4	0,050x2	0,4x2		
FBA35A	x3 RZQG71L8Y1B			13,3	-	16	-	9,6	0,094	0,4	0,089x3	0,6x3		
FBA50A	x2 RZQG71L8Y1B			12,5	-	16	-	9,6	0,094	0,4	0,089x2	0,6x2		
FBA100A	RZQG71L8Y1B			12,3	-	16	-	9,6	0,094	0,4	0,127	1,0		
FHA35A	x3 RZQG71L8Y1B			13,3	-	16	-	9,6	0,094	0,4	0,060x3	0,6x3		
FHA50A	x2 RZQG71L8Y1B			12,5	-	16	-	9,6	0,094	0,4	0,060x2	0,6x2		
FHA100A	RZQG71L8Y1B			12,6	-	16	-	9,6	0,094	0,4	0,150	1,3		
FUA100A	RZQG71L8Y1B			12,6	-	16	-	9,6	0,094	0,4	0,106	1,3		
FAA100A	RZQG71L8Y1B			11,5	-	16	-	9,6	0,094	0,4	0,064	0,4		
FVA100A	RZQG71L8Y1B			12,5	-	16	-	9,6	0,094	0,4	0,238	1,2		
FDXM35F3	x3 RZQG71L8Y1B			12,1	-	16	-	9,6	0,094	0,4	0,034x3	0,3x3		
FDXM50F3	x2 RZQG71L8Y1B			12,3	-	16	-	9,6	0,094	0,4	0,060x2	0,5x2		
FCAHG71G	x2 RZQG100L8Y1B			3N~50Hz 380-415V	Minimum: 342V Maximum: 456V	17,8	-	20	-	14,2	0,094+ 0,094	0,4+ 0,4	0,091 x2	0,5x2
FCAHG140G	RZQG100L8Y1B					18,3	-	20	-	14,2	0,094+ 0,094	0,4+ 0,4	0,244	1,4
FCAG35A	x4 RZQG100L8Y1B					18,0	-	20	-	14,2	0,094+ 0,094	0,4+ 0,4	0,044x4	0,3x4
FCAG50A	x3 RZQG100L8Y1B	17,6	-			20	-	14,2	0,094+ 0,094	0,4+ 0,4	0,039x3	0,3x3		
FCAG71A	x2 RZQG100L8Y1B	17,5	-			20	-	14,2	0,094+ 0,094	0,4+ 0,4	0,054x2	0,4x2		
FCAG140A	RZQG100L8Y1B	17,8	-			20	-	14,2	0,094+ 0,094	0,4+ 0,4	0,168	1,0		
FFA35A	x4 RZQG100L8Y1B	18,5	-			20	-	14,2	0,094+ 0,094	0,4+ 0,4	0,050x4	0,4x4		
FFA50A	x3 RZQG100L8Y1B	18,0	-			20	-	14,2	0,094+ 0,094	0,4+ 0,4	0,050x3	0,4x3		
FBA35A	x4 RZQG100L8Y1B	19,5	-			20	-	14,2	0,094+ 0,094	0,4+ 0,4	0,089x4	0,6x4		
FBA50A	x3 RZQG100L8Y1B	18,8	-			20	-	14,2	0,094+ 0,094	0,4+ 0,4	0,089x3	0,6x3		
FBA71A	x2 RZQG100L8Y1B	17,8	-			20	-	14,2	0,094+ 0,094	0,4+ 0,4	0,070x2	0,5x2		
FBA140A	RZQG100L8Y1B	18,4	-			20	-	14,2	0,094+ 0,094	0,4+ 0,4	0,187	1,5		
FHA35A	x4 RZQG100L8Y1B	19,5	-			20	-	14,2	0,094+ 0,094	0,4+ 0,4	0,060x4	0,6x4		
FHA50A	x3 RZQG100L8Y1B	18,8	-			20	-	14,2	0,094+ 0,094	0,4+ 0,4	0,060x3	0,6x3		
FHA71A	x2 RZQG100L8Y1B	18,5	-			20	-	14,2	0,094+ 0,094	0,4+ 0,4	0,091x2	0,8x2		
FHA140A	RZQG100L8Y1B	18,8	-			20	-	14,2	0,094+ 0,094	0,4+ 0,4	0,150	1,8		
FUA71A	x2 RZQG100L8Y1B	18,8	-			20	-	14,2	0,094+ 0,094	0,4+ 0,4	0,046x2	0,9x2		
FAA71A	x2 RZQG100L8Y1B	17,5	-			20	-	14,2	0,094+ 0,094	0,4+ 0,4	0,048x2	0,4x2		
FVA140A	RZQG100L8Y1B	18,3	-			20	-	14,2	0,094+ 0,094	0,4+ 0,4	0,276	1,4		
FDXM35F3	x4 RZQG100L8Y1B	18,0	-			20	-	14,2	0,094+ 0,094	0,4+ 0,4	0,034x4	0,3x4		
FDXM50F3	x3 RZQG100L8Y1B	18,4	-	20	-	14,2	0,094+ 0,094	0,4+ 0,4	0,060x3	0,5x3				

Symbols	Notes
MCA Min. Circuit Amps. (A) TOCA Total Over-Current Amps. (A) MFA Max. Fuse Amps (See note 7) (A) MSC Max. current during the starting compressor. (A) RLA Rated Load Amps. (A) OFM Outdoor Fan Motor. (A) IFM Indoor Fan Motor. FLA Full Load Amps. kW Fan Motor Rated Output (kW)	<p>1 RLA is based on the following indoor conditions: Power supply: 50Hz 400V Cooling Indoor temperature 27.0°CDB/19.0°CWB Outdoor temperature 35.0°CDB Heating Indoor temperature 20.0°CDB Outdoor temperature 7.0°CDB/6.0°CWB.</p> <p>2 TOCA means the total value of each OC set.</p> <p>3 Voltage range Units are suitable for use on electrical systems where voltage supplied to unit terminals is not below or above listed range limits.</p> <p>4 Maximum allowable voltage variation between phases is 2% .</p> <p>5 MCA represents maximum input current, MFA represents capacity which may accept MCA. (next lower standard fuse rating, min.15A).</p> <p>6 Select wire size based on the larger value of MCA or TOCA.</p> <p>7 MFA is used to select the circuit breaker and the ground fault circuit interrupter. (earth leakage circuit breaker)</p>

RZQG71-100L8Y1

3D098292



RZQG71-100L8Y1

Indoor	Outdoor	Power supply	Voltage range	MCA	TOCA	MFA	Comp		OFM		IFM					
							MSC	RLA	kW	FLA	kW	FLA				
FCAHG71G				18.2	-	20	-	15.6	0.094	0.4	0.091	0.5				
FCAG35A	x2	RZQG71L9V1	50 Hz 220-240V	Min.198V Max.264V	18.4	-	20	-	15.6	0.094	0.4	0.044x2	0.3x2			
FCAG71A					18.1	-	20	-	15.6	0.094	0.4	0.054	0.4			
FFA35A	x2				18.6	-	20	-	15.6	0.094	0.4	0.050x2	0.4x2			
FDXM5F3	x2				18.4	-	20	-	15.6	0.094	0.4	0.034x2	0.3x2			
FBA35A	x2				20.6	-	25	-	15.6	0.094	0.4	0.140x2	1.2x2			
FBA71A					19.0	-	20	-	15.6	0.094	0.4	0.350	1.1			
FAA71A					18.1	-	20	-	15.6	0.094	0.4	0.048	0.4			
FVA71A					18.4	-	20	-	15.6	0.094	0.4	0.117	0.6			
FHA35A	x2				19.1	-	20	-	15.6	0.094	0.4	0.060x2	0.6x2			
FHA71A					18.6	-	20	-	15.6	0.094	0.4	0.091	0.8			
FUA71A					18.7	-	20	-	15.6	0.094	0.4	0.046	0.9			
FCAHG100G							29.1	-	32	-	24.2	0.094+0.094	0.4+0.4	0.221	1.3	
FCAG35A	x3				RZQG100L9V1	50Hz 220-240V	Min.198V Max.264V	28.6	-	32	-	24.2	0.094+0.094	0.4+0.4	0.044x3	0.3x3
FCAG50A	x2							28.3	-	32	-	24.2	0.094+0.094	0.4+0.4	0.039x2	0.3x2
FCAG100A								28.4	-	32	-	24.2	0.094+0.094	0.4+0.4	0.117	0.7
FFA35A	x3							29.0	-	32	-	24.2	0.094+0.094	0.4+0.4	0.050x3	0.4x3
FFA50A	x2							28.5	-	32	-	24.2	0.094+0.094	0.4+0.4	0.050x2	0.4x2
FDXM35F3	x3							28.6	-	32	-	24.2	0.094+0.094	0.4+0.4	0.034x3	0.3x3
FDXM50F3	x2	28.8	-	32				-	24.2	0.094+0.094	0.4+0.4	0.06x2	0.5x2			
FBA35A	x3	32.0	-	40				-	24.2	0.094+0.094	0.4+0.4	0.140x3	1.2x3			
FBA50A	x2	30.5	-	32				-	24.2	0.094+0.094	0.4+0.4	0.140x2	1.2x2			
FBA100A		29.5	-	32				-	24.2	0.094+0.094	0.4+0.4	0.350	1.6			
FAA100A		28.0	-	32				-	24.2	0.094+0.094	0.4+0.4	0.064	0.4			
FVA100A		29.0	-	32				-	24.2	0.094+0.094	0.4+0.4	0.238	1.2			
FHA35A	x3	29.8	-	32				-	24.2	0.094+0.094	0.4+0.4	0.060x3	0.6x3			
FHA50A	x2	29.0	-	32				-	24.2	0.094+0.094	0.4+0.4	0.060x2	0.6x2			
FUA100A		29.1	-	32				-	24.2	0.094+0.094	0.4+0.4	0.150	1.3			
FUA100A		29.1	-	32				-	24.2	0.094+0.094	0.4+0.4	0.106	1.3			

Symbols	Notes
MCA Min. Circuit Amps. (A)	<p>1 RLA is based on the following indoor conditions: Power supply: 50Hz 400V Cooling Indoor temperature 27.0°CDB/19.0°CWB Outdoor temperature 35.0°CDB Heating Indoor temperature 20.0°CDB Outdoor temperature 7.0°CDB/6.0°CWB.</p> <p>2 TOCA means the total value of each OC set.</p> <p>3 Voltage range: Units are suitable for use on electrical systems where voltage supplied to unit terminals is not below or above listed range limits.</p> <p>4 Maximum allowable voltage variation between phases is 2%.</p> <p>5 MCA represents maximum input current, MFA represents capacity which may accept MCA. (next lower standard fuse rating, min.15A).</p> <p>6 Select wire size based on the larger value of MCA or TOCA.</p> <p>7 MFA is used to select the circuit breaker and the ground fault circuit interrupter. (earth leakage circuit breaker)</p>
TOCA Total Over-Current Amps. (A)	
MFA Max. Fuse Amps (See note 7) (A)	
MSC Max. current during the starting compressor. (A)	
RLA Rated Load Amps. (A)	
OFM Outdoor Fan Motor. (A)	
IFM Indoor Fan Motor.	
FLA Full Load Amps.	
kW Fan Motor Rated Output (kW)	

RZQG71-100L9V1

3D090680

RZQG71-100L8Y1

Indoor	Outdoor	Power supply	Voltage range	MCA	TOCA	MFA	Compressor		OFM		IFM					
							MSC	RLA	kW	FLA	kW	FLA				
FCAHG100G				19.2	-	20	-	15.6	0,094	0.4	0,221	1,3				
FCAG35A	x3	RZQG71L9V1B	1~ 50Hz 220-240V	Minimum: 198V Maximum: 264V	18.7	-	20	-	15.6	0,094	0.4	0,044x3	0,3x3			
FCAG50A	x2				18.4	-	20	-	15.6	0,094	0.4	0,039x2	0,3x2			
FCAG100A					18.5	-	20	-	15.6	0,094	0.4	0,117	0,7			
FFA35A	x3				19.1	-	20	-	15.6	0,094	0.4	0,050x3	0,4x3			
FFA50A	x2				18.6	-	20	-	15.6	0,094	0.4	0,050x2	0,4x2			
FBA35A	x3				19.9	-	25	-	15.6	0,094	0.4	0,089x3	0,6x3			
FBA50A	x2				19.9	-	25	-	15.6	0,094	0.4	0,089x2	0,6x2			
FBA100A					18.9	-	20	-	15.6	0,094	0.4	0,127	1,0			
FHA35A	x3				19.9	-	25	-	15.6	0,094	0.4	0,060x3	0,6x3			
FHA50A	x2				19.1	-	20	-	15.6	0,094	0.4	0,060x2	0,6x2			
FHA100A					19.2	-	20	-	15.6	0,094	0.4	0,150	1,3			
FUA100A					19.2	-	20	-	15.6	0,094	0.4	0,106	1,3			
FAA100A					18.1	-	20	-	15.6	0,094	0.4	0,064	0,4			
FVA100A					19.1	-	20	-	15.6	0,094	0.4	0,238	1,2			
FDXM35F3	x3				18.7	-	20	-	15.6	0,094	0.4	0,034x3	0,3x3			
FDXM50F3	x2				18.9	-	20	-	15.6	0,094	0.4	0,06x3	0,5x2			
FCAHG71G	x2				RZQG100L9V1B	1~ 50Hz 220-240V	Minimum: 198V Maximum: 264V	28.8	-	32	-	24.2	0,094+0.094	0.4+0.4	0,091x2	0,5x2
FCAHG140G								29.3	-	32	-	24.2	0,094+0.094	0.4+0.4	0,244	1,4
FCAG35A	x4	29.0	-	32				-	24.2	0,094+0.094	0.4+0.4	0,044x4	0,3x4			
FCAG50A	x3	28.6	-	32				-	24.2	0,094+0.094	0.4+0.4	0,039x3	0,3x3			
FCAG71A	x2	28.5	-	32				-	24.2	0,094+0.094	0.4+0.4	0,054x2	0,4x2			
FCAG140A		28.8	-	32				-	24.2	0,094+0.094	0.4+0.4	0,168	1,0			
FFA35A	x4	29.5	-	32				-	24.2	0,094+0.094	0.4+0.4	0,050x4	0,4x4			
FFA50A	x3	29.0	-	32				-	24.2	0,094+0.094	0.4+0.4	0,050x3	0,4x3			
FBA35A	x4	30.5	-	32				-	24.2	0,094+0.094	0.4+0.4	0,089x4	0,6x4			
FBA50A	x3	29.8	-	32				-	24.2	0,094+0.094	0.4+0.4	0,089x3	0,6x3			
FBA71A	x2	28.8	-	32				-	24.2	0,094+0.094	0.4+0.4	0,070x2	0,5x2			
FBA140A		29.4	-	32				-	24.2	0,094+0.094	0.4+0.4	0,187	1,5			
FHA35A	x4	30.5	-	32				-	24.2	0,094+0.094	0.4+0.4	0,060x4	0,6x4			
FHA50A	x3	29.8	-	32				-	24.2	0,094+0.094	0.4+0.4	0,060x3	0,6x3			
FHA71A	x2	29.5	-	32				-	24.2	0,094+0.094	0.4+0.4	0,091x2	0,8x2			
FHA140A		29.8	-	32				-	24.2	0,094+0.094	0.4+0.4	0,150	1,8			
FUA71A	x2	29.8	-	32				-	24.2	0,094+0.094	0.4+0.4	0,046x2	0,9x2			
FAA71A	x2	28.5	-	32				-	24.2	0,094+0.094	0.4+0.4	0,048x2	0,4x2			
FVA140A		29.3	-	32	-	24.2	0,094+0.094	0.4+0.4	0,276	1,4						
FDXM35F3	x4	29.0	-	32	-	24.2	0,094+0.094	0.4+0.4	0,034x4	0,3x4						
FDXM50F3	x3	29.4	-	32	-	24.2	0,094+0.094	0.4+0.4	0,060 x3	0,5x3						

Symbols	Notes
MCA Min. Circuit Amps. (A)	<p>1 RLA is based on the following indoor conditions: Power supply: 50Hz 400V Cooling Indoor temperature 27.0°CDB/19.0°CWB Outdoor temperature 35.0°CDB Heating Indoor temperature 20.0°CDB Outdoor temperature 7.0°CDB/6.0°CWB.</p> <p>2 TOCA means the total value of each OC set.</p> <p>3 Voltage range: units are suitable for use on electrical systems where voltage supplied to unit terminals is not below or above listed range limits.</p> <p>4 Maximum allowable voltage variation between phases is 2%.</p> <p>5 MCA represents maximum input current, MFA represents capacity which may accept MCA. (next lower standard fuse rating, min.15A).</p> <p>6 Select wire size based on the larger value of MCA or TOCA.</p> <p>7 MFA is used to select the circuit breaker and the ground fault circuit interrupter. (earth leakage circuit breaker)</p>
TOCA Total Over-Current Amps. (A)	
MFA Max. Fuse Amps (See note 7) (A)	
MSC Max. current during the starting compressor. (A)	
RLA Rated Load Amps. (A)	
OFM Outdoor Fan Motor. (A)	
IFM Indoor Fan Motor.	
FLA Full Load Amps.	
kW Fan Motor Rated Output (kW)	

RZQG71-100L9V1

3D098291



RZQG100-125L8Y1

Unit combination		Minimum Ssc value [kVA]
FFA35A	x3	936
FFA50A	x2	951
FFA35A	x3	977
FHA50A	x2	936
FBA35A	x3	1092
FBA50A	x2	1014
FCAG35A	x3	915
FCAG50A	x2	899
FBA100A	x1	862
FCAG100A	x1	905
FCAHG100G	x1	941
FAA100A	x1	884
FVA100A	x1	936
FHAG100G	x1	936
FUA100A	x1	925
FFA35A	x4	962
FFA50A	x3	993
FFA60A	x2	951
FHA35A	x4	1014
FHA50A	x3	977
FHA60A	x2	936
FBA35A	x4	1170
FBA50A	x3	1092
FBA60A	x2	1003
FCAG35A	x4	936
FCAG50A	x3	915
FCAG60A	x2	899
FBA125A	x1	993
FCAG125A	x1	925
FCAHG125G	x1	951
FVA125A	x1	936
FCAHG125G	x1	962
FUA125A	x1	925
FDA125A	x1	993

NOTES

- In accordance with EN/IEC 61000-3-12⁽¹⁾, it may be necessary to consult the distribution network operator to ensure that the equipment is connected only to a supply with $S_{sc}^{(2)} \geq$ minimum Ssc value.
- (1) European/International technical standard setting the limits for harmonic currents produced by equipment connected to public low-voltage system with input current > 16A and \leq 75A per phase.
- (2) Short-circuit power.

RZQG100-125L8Y1

3D079056

RZQG100-140L(8)Y1

Unit combination restrictions		Power supply			COMP			OFM		IFM				
Indoor	Outdoor	1	2	3	MCA	MFA	RHz	RLA	kW	FLA	kW	FLA		
3xFBA35A	RZQG100L8Y18	3N ~ 50Hz	380 -415V	MAX. 50Hz 456V Min. 50Hz 342V	18.7	20	-	14.2	0.094+ 0.094	0.4+0.4	3x0.089	3x0.6		
FBA125A	RZQG125L8Y18				18.5	20	-	14.2	0.094+ 0.094	0.4+0.4	0,187	1,5		
2xFBA60A	RZQG125L8Y18				18	20	-	14.2	0.094+ 0.094	0.4+0.4	2x0.07	2x0.5		
3xFBA50A	RZQG125L8Y18				18,8	20	-	14.2	0.094+ 0.094	0.4+0.4	3x0.089	3x0.6		
4xFBA35A	RZQG125L8Y18				19.4	20	-	14.2	0.094+ 0.094	0.4+0.4	4x0.089	4x0.6		
FBA140A	RZQG140L7Y18				18.5	20	-	14.2	0.094+ 0.094	0.4+0.4	0,187	1,5		
2xFBA71A	RZQG140L7Y18				18	20	-	14.2	0.094+ 0.094	0.4+0.4	2x0.07	2x0.5		
3xFBA50A	RZQG140L7Y18				18.8	20	-	14.2	0.094+ 0.094	0.4+0.4	3x0.089	3x0.6		
4xFBA35A	RZQG140L7Y18				19.4	20	-	14.2	0.094+ 0.094	0.4+0.4	4x0.089	4x0.6		

Symbols

- 1 - HZ
- 2 - Voltage
- 3 - Voltage range
- MCA Minimum Circuit Ampere (A)
- MFA Maximum Fuse Ampere (A)
- RLA Rared Load Amps [A]
- OFM Outdoor Fan Motor
- IFM Indoor Fan Motor
- FLA Full Load Ampere (A)
- kW Fan motor rated output [kW]
- RHz Rated operating frequency [Hz]
- COMP Compressor

Notes

- The RLA is based on the following conditions.
Indoor temperature 27° CDB / 19° CWB.
Outdoor temperature 35° CDB.
- Select the wire size according to the MCA.
- The maximum allowable voltage is unbalanced between phases is 2%.
- Use a circuit breaker instead of a fuse.

RZQG100-140L(8)Y1

300948636



RZQG100-140L(8)Y1

Unit combination restrictions		Power supply			COMP				OFM		IFM	
Indoor	Outdoor	1	2	3	MCA	MFA	RHz	RLA	kW	FLA	kW	FLA
3xFNA35A	RZQG100L8Y1B	3N~ 50Hz	380- 415V	MAX. 50Hz 456V MIN. 50Hz 342V	17.8	20	-	14.2	0.094+0.094	0.4+0.4	3x0.034	3x0.3
2xFNA60A	RZQG125L8Y1B				18	20	-	14.2	0.094+0.094	0.4+0.4	2x0.06	2x0.5
3xFNA50A	RZQG125L8Y1B				18.5	20	-	14.2	0.094+0.094	0.4+0.4	3x0.06	3x0.5
4xFNA35A	RZQG125L8Y1B				18.2	20	-	14.2	0.094+0.094	0.4+0.4	4x0.034	4x0.3
3xFNA50A	RZQG140L7Y1B				18.5	20	-	14.2	0.094+0.094	0.4+0.4	3x0.06	3x0.5
4xFNA35A	RZQG140L7Y1B				18.2	20	-	14.2	0.094+0.094	0.4+0.4	4x0.034	4x0.3

Symbols	Notes
1 - Hz 2 - Voltage 3 - Voltage range MCA Minimum Circuit Ampere (A) MFA Maximum Fuse Ampere (A) RLA Rared Load Amps [A] OFM Outdoor Fan Motor IFM Indoor Fan Motor FLA Full Load Ampere (A) kW Fan motor rated output [kW] RHz Rated operating frequency [Hz] COMP Compressor	<p>1 The RLA is based on the following conditions. Indoor temperature 27° CDB / 19° CWB. Outdoor temperature 35° CDB.</p> <p>2 Select the wire size according to the MCA.</p> <p>3 The maximum allowable voltage is unbalanced between phases is 2%.</p> <p>4 Use a circuit breaker instead of a fuse.</p>

RZQG100-140L(8)Y1

3D096315C

RZQG125-140L(8)Y1

Indoor	Outdoor	Power supply	Voltage range	Compressor				OFM		IFM			
				MCA	TOCA	MFA	MSC	RLA	kW	FLA	kW	FLA	
FCAG125A		RZQG125L8Y1B	3N - SOHz 380 - 415V	Min. 342V Max. 456V	17.9	-	20	-	14.2	0.094+0.094	0.4+0.4	0.106	1.1
FCAHG125G					18.3	-	20	-	14.2	0.094+0.094	0.4+0.4	0.244	1.4
FCAG35A	x4				18.0	-	20	-	14.2	0.094+0.094	0.4+0.4	0.044x4	0.3x4
FCAG50A	x3				17.6	-	20	-	14.2	0.094+0.094	0.4+0.4	0.039x3	0.3x3
FCAG60A	x2				17.3	-	20	-	14.2	0.094+0.094	0.4+0.4	0.044x2	0.3x2
FCAG125A					17.8	-	20	-	14.2	0.094+0.094	0.4+0.4	0.168	1.0
FFA35A	x4				18.5	-	20	-	14.2	0.094+0.094	0.4+0.4	0.05x4	0.4x4
FFA50A	x3				18.0	-	20	-	14.2	0.094+0.094	0.4+0.4	0.05x3	0.4x3
FFA60A	x2				18.0	-	20	-	14.2	0.094+0.094	0.4+0.4	0.05x2	0.6x2
FDXM35F3	x4				18.0	-	20	-	14.2	0.094+0.094	0.4+0.4	0.034x4	0.3x4
FDXM50F3	x3				18.4	-	20	-	14.2	0.094+0.094	0.4+0.4	0.06x3	0.5x3
FDXM60F3	x2				17.8	-	20	-	14.2	0.094+0.094	0.4+0.4	0.060x2	0.5x2
FBA35A	x4				22.5	-	25	-	14.2	0.094+0.094	0.4+0.4	0.140x4	1.2x4
FBA50A	x3				21.0	-	25	-	14.2	0.094+0.094	0.4+0.4	0.140x3	1.2x3
FBA60A	x2				19.3	-	20	-	14.2	0.094+0.094	0.4+0.4	0.350x2	1.1x2
FBA125AB					19.1	-	20	-	14.2	0.094+0.094	0.4+0.4	0.350	2.1
FDA125A					19.1	-	20	-	14.2	0.094+0.094	0.4+0.4	0.350	2.1
FVA125A					18.0	-	20	-	14.2	0.094+0.094	0.4+0.4	0.238	1.2
FHA35A	x4				19.5	-	20	-	14.2	0.094+0.094	0.4+0.4	0.060x4	0.6x4
FHA50A	x3				18.8	-	20	-	14.2	0.094+0.094	0.4+0.4	0.060x3	0.6x4
FHA60A	x2				18.0	-	20	-	14.2	0.094+0.094	0.4+0.4	0.091x2	0.6x3
FHA125A					18.4	-	20	-	14.2	0.094+0.094	0.4+0.4	0.150	1.5
FUA125A					18.3	-	20	-	14.2	0.094+0.094	0.4+0.4	0.106	1.4
FCAG71A	x2				17.5	-	20	-	14.2	0.094+0.094	0.4+0.4	0.048x2	0.4x2
FCAG140A					17.9	-	20	-	14.2	0.094+0.094	0.4+0.4	0.106	1.1
FCAHG71G	x2				17.8	-	20	-	14.2	0.094+0.094	0.4+0.4	0.091x2	0.5x2
FCAHG 140G					18.3	-	20	-	14.2	0.094+0.094	0.4+0.4	0.244	1.4
FCAG35A	x4				18.0	-	20	-	14.2	0.094+0.094	0.4+0.4	0.044x4	0.3x4
FCAG50A	x3	17.6	-	20	-	14.2	0.094+0.094	0.4+0.4	0.039x3	0.3x3			
FCAG71A	x2	17.5	-	20	-	14.2	0.094+0.094	0.4+0.4	0.054x2	0.4x2			
FCAG140A		17.8	-	20	-	14.2	0.094+0.094	0.4+0.4	0.168	1.0			
FFA35AB	x4	18.5	-	20	-	14.2	0.094+0.094	0.4+0.4	0.05x4	0.4x4			
FFA50A	x3	18.0	-	20	-	14.2	0.094+0.094	0.4+0.4	0.05x3	0.4x3			
FDXM35F3	x4	18.0	-	20	-	14.2	0.094+0.094	0.4+0.4	0.034x4	0.3x4			
FDXM50F3	x4	18.4	-	20	-	14.2	0.094+0.094	0.4+0.4	0.06x3	0.5x3			
FBA35A	x4	22.5	-	25	-	14.2	0.094+0.094	0.4+0.4	0.140x4	1.2x4			
FBA50A	x3	21.0	-	25	-	14.2	0.094+0.094	0.4+0.4	0.140x3	1.2x3			
FBA71A	x2	19.3	-	20	-	14.2	0.094+0.094	0.4+0.4	0.350x2	1.1x2			
FBA140A		19.1	-	20	-	14.2	0.094+0.094	0.4+0.4	0.350	2.1			
FHA140A		18.8	-	20	-	14.2	0.094+0.094	0.4+0.4	0.150	1.8			
FUA71A	x2	18.8	-	20	-	14.2	0.094+0.094	0.4+0.4	0.046x2	0.9x2			

Symbols	Notes
MCA Min. Circuit Amps. (A) TOCA Total Over-Current Amps. (A) MFA Max. Fuse Amps (See note 7) (A) MSC Max. current during the starting compressor. (A) RLA Rated Load Amps. (A) OFM Outdoor Fan Motor. (A) IFM Indoor Fan Motor. FLA Full Load Amps. kW Fan Motor Rated Output (kW)	<p>1 RLA is based on the following indoor conditions: Power supply: 50Hz 400V Cooling Indoor temperature 27.0°CDB/19.0°CWB Outdoor temperature 35.0°CDB Heating Indoor temperature 20.0°CDB Outdoor temperature 7.0°CDB/6.0°CWB.</p> <p>2 TOCA means the total value of each OC set.</p> <p>3 Voltage range Units are suitable for use on electrical systems where voltage supplied to unit terminals is not below or above listed range limits.</p> <p>4 Maximum allowable voltage variation between phases is 2% .</p> <p>5 MCA represents maximum input current, MFA represents capacity which may accept MCA. (next lower standard fuse rating, min.15A).</p> <p>6 Select wire size based on the larger value of MCA or TOCA.</p> <p>7 MFA is used to select the circuit breaker and the ground fault circuit interrupter. (earth leakage circuit breaker)</p>

RZQG125-140L(8)Y1

3D077810B



Detailed technical drawings

RZQG125-140L(8)Y1

Indoor	Outdoor	Power supply	Voltage range	MCA	TOCA	MFA	Compressor		OFM		IFM			
							MSC	RLA	kW	FLA	kW	FLA		
FCAHG71G	x2 RZQG125L8Y1B	3N~50Hz 380-415V	Minimum: 342V Maximum: 456V	17,8	-	20	-	14.2	0.094+ 0.094	0.4+0.4	0,091x2	0.5x2		
FCAHG140G	RZQG125L8Y1B			18,3	-	20	-	14.2	0.094+ 0.094	0.4+0.4	0,244	1.4		
FCAG35A	x4 RZQG125L8Y1B			18,0	-	20	-	14.2	0.094+ 0.094	0.4+0.4	0,044x4	0.3x4		
FCAG50A	x3 RZQG125L8Y1B			17,6	-	20	-	14.2	0.094+ 0.094	0.4+0.4	0,039x3	0.3x3		
FCAG71A	x2 RZQG125L8Y1B			17,5	-	20	-	14.2	0.094+ 0.094	0.4+0.4	0,054x2	0.4x2		
FCAG140A	RZQG125L8Y1B			17,8	-	20	-	14.2	0.094+ 0.094	0.4+0.4	0,168	1.0		
FFA35A	x4 RZQG125L8Y1B			18,5	-	20	-	14.2	0.094+ 0.094	0.4+0.4	0,050x4	0.4x4		
FBA50A	x3 RZQG125L8Y1B			18,0	-	20	-	14.2	0.094+ 0.094	0.4+0.4	0,050x3	0.4x3		
FBA35A	x4 RZQG125L8Y1B			19,5	-	20	-	14.2	0.094+ 0.094	0.4+0.4	0,089x4	0.6x4		
FBA50A	x3 RZQG125L8Y1B			18,8	-	20	-	14.2	0.094+ 0.094	0.4+0.4	0,089x3	0.6x3		
FBA71A	x2 RZQG125L8Y1B			17,8	-	20	-	14.2	0.094+ 0.094	0.4+0.4	0,070x2	0.5x2		
FBA140A	RZQG125L8Y1B			18,4	-	20	-	14.2	0.094+ 0.094	0.4+0.4	0,187	1.5		
FHA35A	x4 RZQG125L8Y1B			19,5	-	20	-	14.2	0.094+ 0.094	0.4+0.4	0,060x4	0.6x4		
FHA50A	x3 RZQG125L8Y1B			18,8	-	20	-	14.2	0.094+ 0.094	0.4+0.4	0,060x3	0.6x3		
FHA71A	x2 RZQG125L8Y1B			18,5	-	20	-	14.2	0.094+ 0.094	0.4+0.4	0,091x2	0.8x2		
FHA140A	RZQG125L8Y1B			18,8	-	20	-	14.2	0.094+ 0.094	0.4+0.4	0,150	1.8		
FUA71A	x2 RZQG125L8Y1B			18,8	-	20	-	14.2	0.094+ 0.094	0.4+0.4	0,046x2	0.9x2		
FAA71AB	x2 RZQG125L8Y1B			17,5	-	20	-	14.2	0.094+ 0.094	0.4+0.4	0,048x2	0.4x2		
FVA140A	RZQG125L8Y1B			18,3	-	20	-	14.2	0.094+ 0.094	0.4+0.4	0,276	1.4		
FDXM35F3	x4 RZQG125L8Y1B			18,0	-	20	-	14.2	0.094+ 0.094	0.4+0.4	0,034x4	0.3x4		
FDXM50F3	x3 RZQG125L8Y1B			18,4	-	20	-	14.2	0.094+ 0.094	0.4+0.4	0,060x3	0.5x3		
FCAHG71G	x2 RZQG140L7Y1B			3N~50Hz 380-415V	Minimum: 342V Maximum: 456V	17,8	-	20	-	14.2	0.094+ 0.094	0.4+0.4	0,091x2	0.5x2
FCAHG140G	RZQG140L7Y1B					18,3	-	20	-	14.2	0.094+ 0.094	0.4+0.4	0,244	1.4
FCAG35A	x4 RZQG140L7Y1B					18,0	-	20	-	14.2	0.094+ 0.094	0.4+0.4	0,044x4	0.3x4
FCAG50AB	x3 RZQG140L7Y1B					17,6	-	20	-	14.2	0.094+ 0.094	0.4+0.4	0,039x3	0.3x3
FCAG71A	x2 RZQG140L7Y1B					17,5	-	20	-	14.2	0.094+ 0.094	0.4+0.4	0,054x2	0.4x2
FCAG140A	RZQG140L7Y1B					17,8	-	20	-	14.2	0.094+ 0.094	0.4+0.4	0,168	1.0
FFA35A	x4 RZQG140L7Y1B					18,5	-	20	-	14.2	0.094+ 0.094	0.4+0.4	0,050x4	0.4x4
FBA50A	x3 RZQG140L7Y1B	18,0	-			20	-	14.2	0.094+ 0.094	0.4+0.4	0,050x3	0.4x3		
FBA35A	x4 RZQG140L7Y1B	19,5	-			20	-	14.2	0.094+ 0.094	0.4+0.4	0,089x4	0.6x4		
FBA50A	x3 RZQG140L7Y1B	18,8	-			20	-	14.2	0.094+ 0.094	0.4+0.4	0,089x3	0.6x3		
FBA71A	x2 RZQG140L7Y1B	17,8	-			20	-	14.2	0.094+ 0.094	0.4+0.4	0,070x2	0.5x2		
FBA140A	RZQG140L7Y1B	18,4	-			20	-	14.2	0.094+ 0.094	0.4+0.4	0,187	1.5		
FHA35A	x4 RZQG140L7Y1B	19,5	-			20	-	14.2	0.094+ 0.094	0.4+0.4	0,060x4	0.6x4		
FHA50A	x3 RZQG140L7Y1B	18,8	-			20	-	14.2	0.094+ 0.094	0.4+0.4	0,060x3	0.6x3		
FHA71A	x2 RZQG140L7Y1B	18,5	-			20	-	14.2	0.094+ 0.094	0.4+0.4	0,091x2	0.8x2		
FHA140A	RZQG140L7Y1B	18,8	-			20	-	14.2	0.094+ 0.094	0.4+0.4	0,150	1.8		
FUA71A	x2 RZQG140L7Y1B	18,8	-			20	-	14.2	0.094+ 0.094	0.4+0.4	0,046x2	0.9x2		
FAA71A	x2 RZQG140L7Y1B	17,5	-			20	-	14.2	0.094+ 0.094	0.4+0.4	0,048x2	0.4x2		
FVA140A	RZQG140L7Y1B	18,3	-			20	-	14.2	0.094+ 0.094	0.4+0.4	0,276	1.4		
FDXM35F3	x4 RZQG140L7Y1B	18,0	-			20	-	14.2	0.094+ 0.094	0.4+0.4	0,034x4	0.3x4		
FDXM50F3	x3 RZQG140L7Y1B	18,4	-			20	-	14.2	0.094+ 0.094	0.4+0.4	0,060x3	0.5x3		

Symbols	Notes
<p>MCA Min. Circuit Amps. (A)</p> <p>TOCA Total Over-Current Amps. (A)</p> <p>MFA Max. Fuse Amps (See note 7) (A)</p> <p>MSC Max. current during the starting compressor. (A)</p> <p>RLA Rated Load Amps. (A)</p> <p>OFM Outdoor Fan Motor. (A)</p> <p>IFM Indoor Fan Motor.</p> <p>FLA Full Load Amps.</p> <p>kW Fan Motor Rated Output (kW)</p>	<p>1 RLA is based on the following indoor conditions: Power supply: 50Hz 400V Cooling Indoor temperature 27.0°CDB/19.0°CWB Outdoor temperature 35.0°CDB Heating Indoor temperature 20.0°CDB Outdoor temperature 7.0°CDB/6.0°CWB.</p> <p>2 TOCA means the total value of each OC set.</p> <p>3 Voltage range Units are suitable for use on electrical systems where voltage supplied to unit terminals is not below or above listed range limits.</p> <p>4 Maximum allowable voltage variation between phases is 2% .</p> <p>5 MCA represents maximum input current, MFA represents capacity which may accept MCA. (next lower standard fuse rating, min.15A).</p> <p>6 Select wire size based on the larger value of MCA or TOCA.</p> <p>7 MFA is used to select the circuit breaker and the ground fault circuit interrupter. (earth leakage circuit breaker)</p>



RZQG-L9V1/L8Y1

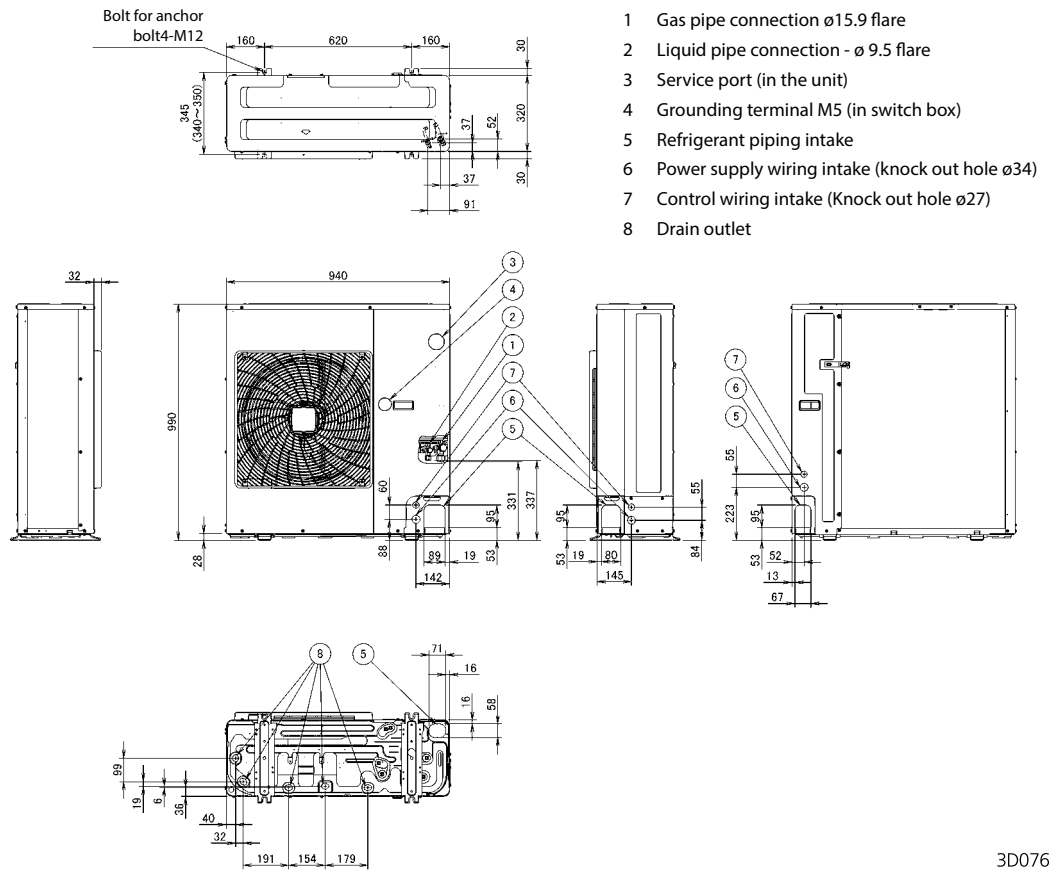

3D076345

RZQG100-140L9V1/L8Y1

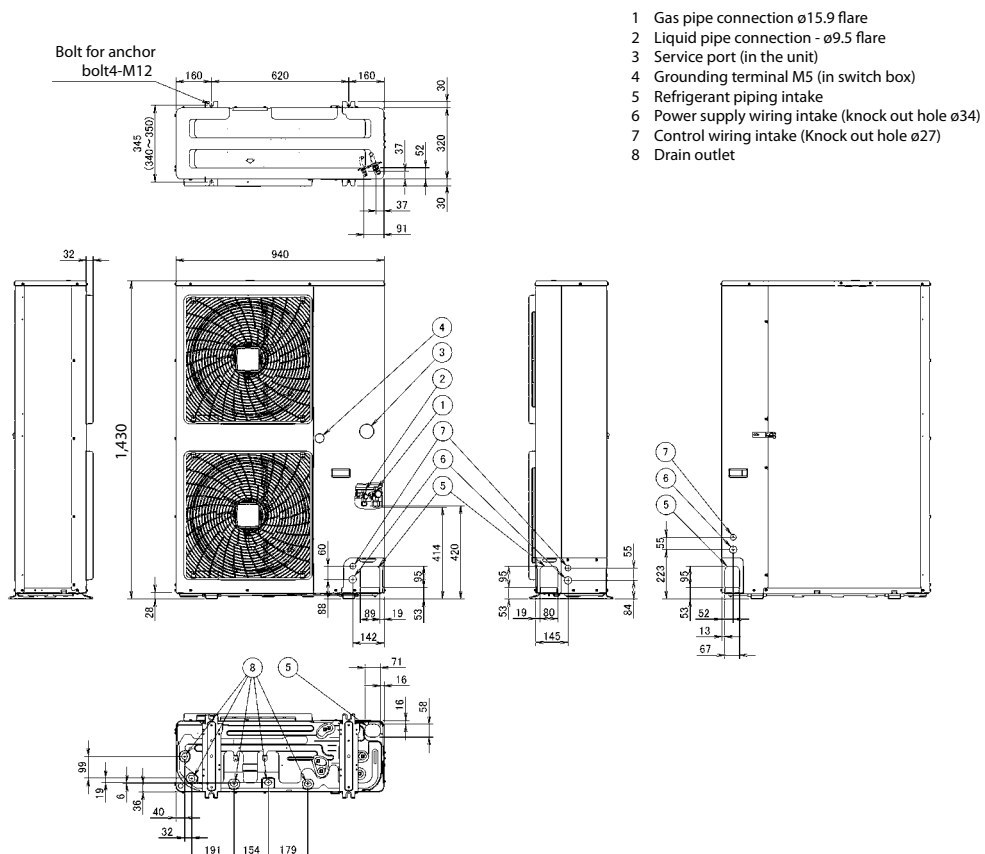

3D076346

RZQG-L9V1/L8Y1

Installation service space

(A) When there are obstacles on suction sides.

• No obstacle above

- ① Stand-alone installation
 - Obstacle on the suction side only

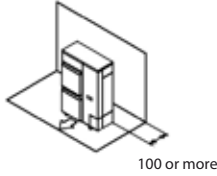

- Obstacle on both sides and suction side, too

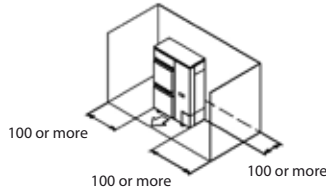

- ② Series installation (2 or more) (Note 1)
 - Obstacle on the suction side and both sides

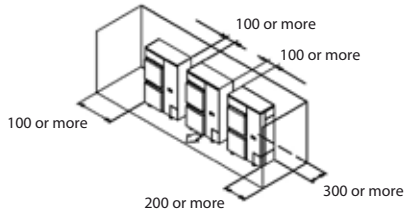

• Obstacle above, too.

- ① Stand-alone installation
 - Obstacle on the suction side, too

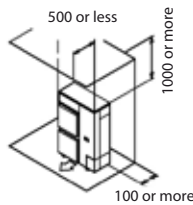

- Obstacle on both sides and suction side, too

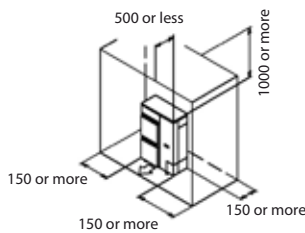

- ② Series installation (2 or more) (Note 1)
 - Obstacle on the suction side and both sides

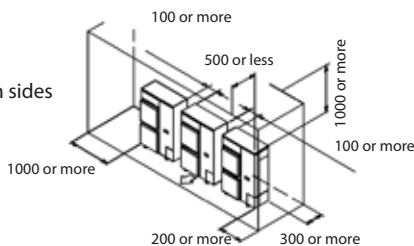

(B) When there are obstacles on discharge sides.

• No obstacle above

- ① Stand-alone installation
 - Obstacle on the discharge side only

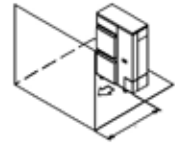

- ② Series installation (2 or more) (Note 1)
 - Obstacle on the suction side only

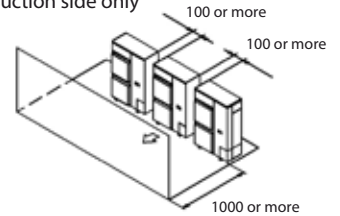

• Obstacle above, too.

- ① Stand-alone installation
 - Obstacle on the discharge side only, too

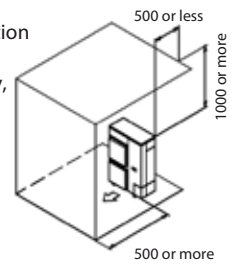

- ② Series installation (2 or more) (Note 1)
 - Obstacle on discharge side

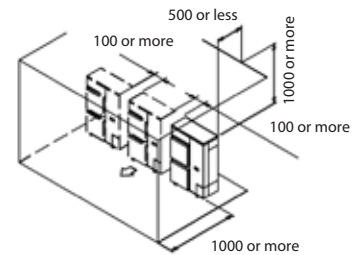

(C) When there are obstacles on both suction and discharge sides:

Pattern 1

When the obstacles on the discharge side is higher than the unit. (L > H)
(There is no limit for the height of obstructions on the suction side.)

• No obstacle above

- ① Stand-alone installation
 - No obstacle above

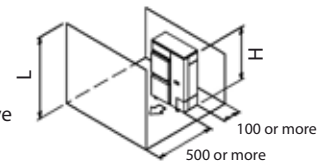

- ② Series installation (2 or more) (Note 1)
 - No obstacle above

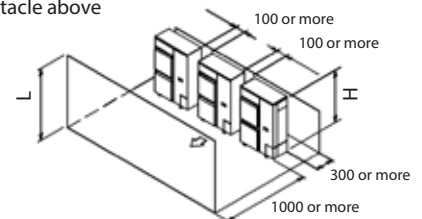

3D069554



RZQG-L9V1/L8Y1

• Obstacle above, too

- ① Stand-alone installation (Note 2)
• When there are obstacles on suction, discharge and top sides.

The relations between H, A and L are as follows.

	L	A
$L \leq H$	$L \leq 1/2 H$	750 or more
	$1/2 H < L \leq H$	1000 or more
$L > H$	Set the stand as : $L \leq H$ Refer to the column of $L \leq H$ for A	

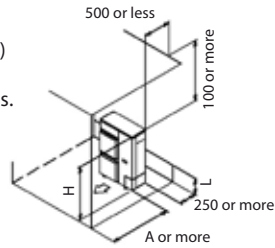

- ② Series installation (2 or more) (Note 1,2)

- When there are obstacles on suction, discharge and top sides.

The relations between H, A and L are as follows.

	L	A
$L \leq H$	$L \leq 1/2 H$	1000 or more
	$1/2 H < L \leq H$	1250 or more
$L > H$	Set the stand as : $L \leq H$ Refer to the column of $L \leq H$ for A	

Limit of series installation is 2 units.

Pattern 2

When the obstacle on the discharge side is lower than the unit ($L \leq H$) (There is no limit for the height of obstructions on the suction side.)

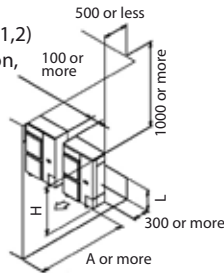

• No obstacle above

- ① Stand-alone installation
• No obstacle above

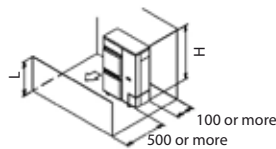

- ② Series installation (2 or more) (Note 1,2)

- When there are obstacles on both suction and discharge sides.

The relations between H, A and L are as follows.

	L	A
$L \leq H$	$L \leq 1/2 H$	250 or more
	$1/2 H < L \leq H$	300 or more

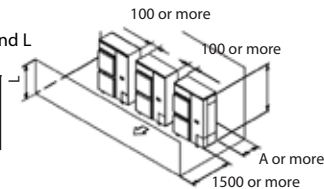

• Obstacle above

- ① Stand-alone installation (Note 2)
• When there are obstacles on suction, discharge and top sides.

The relations between H, A and L are as follows.

	L	A
$L \leq H$	$L \leq 1/2 H$	100 or more
	$1/2 H < L \leq H$	200 or more
$L > H$	Set the stand as : $L \leq H$ Refer to the column of $L \leq H$ for A	

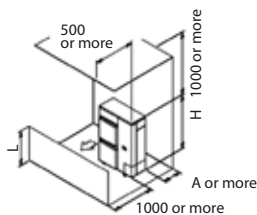

- ② Series installation (2 or more) (Note 1,2)

- When there are obstacles on suction, discharge and top sides.

The relations between H, A and L are as follows.

	L	A
$L \leq H$	$L \leq 1/2 H$	250 or more
	$1/2 H < L \leq H$	300 or more
$L > H$	Set the stand as : $L \leq H$ Refer to the column of $L \leq H$ for A	

Limit of series installation is 2 units.

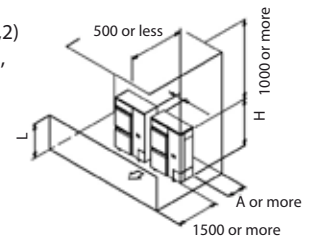

(D) Double-decker installation

- ① Obstacle on the discharge side. (1)

- Do not exceed two levels for stacked installation.
- Install a roof cover similar to A (field supply), as outdoor units with downward drainage are prone to dripping and freezing.
- Install the upper-level outdoor unit so that its bottom plate is a sufficient height above the roof cover. This is to prevent the buildup of ice on the underside of the bottom plate.

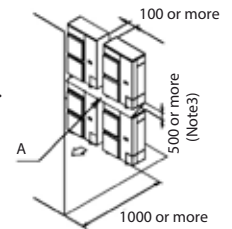

- ② Obstacle on the suction side. (1)

- Do not exceed two levels for stacked installation.
- Install a roof cover similar to A (field supply), as outdoor units with downward drainage are prone to dripping and freezing.
- Install the upper-level outdoor unit so that its bottom plate is a sufficient height above the roof cover. This is to prevent the buildup of ice on the underside of the bottom plate.

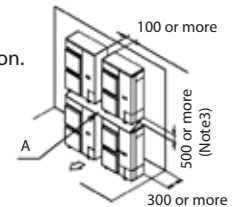

(E) Multiple rows of series installation (on the rooftop, etc.)

- ① One row of stand-alone installation

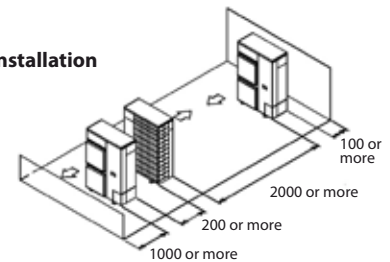

- ② Rows of series installation (2 or more)

The relations between H, A and L are as follows.

	L	A
$L \leq H$	$L \leq 1/2 H$	250 or more
	$1/2 H < L \leq H$	300 or more
$L > H$	Can not be installed	

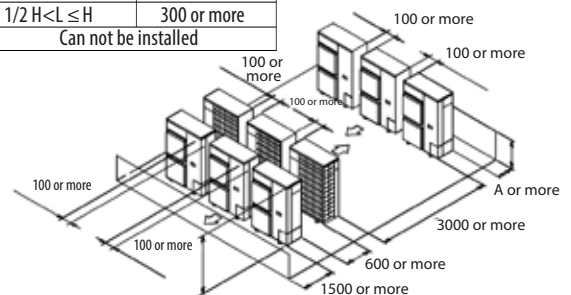

NOTES

1. In case of the sideways's piping, make a 100mm gap between the unit above.
2. Close the bottom of the installation frame to prevent the discharged air from being bypassed.
3. It is not necessary to install a roof cover if there is no danger of drainage dripping and freezing. In this case, the space between the upper and lower outdoor units should be at least 100mm. Close off the gap between the upper and lower units so there is no re-intake of discharged air.

3D069554



Detailed technical drawings

RZQG-L9V1/L8Y1

3.4 Charging refrigerant

Definitions: L1~L7, H1, H2

3.4.1



a) Assume that the longest line in the illustration corresponds with the actual longest pipe, and the highest unit in the illustration corresponds with the actual highest unit.

- L1 Main piping
- L2~L7 Branch piping
- H1 Height difference between the highest indoor unit and the outdoor unit
- H2 Height difference between the highest and the lowest indoor unit
- Refrigerant branch kit

3.4.2 To determine the additional refrigerant amount

To determine if adding additional refrigerant is necessary

if	Then
$(L1+L2+L3+L4+L5+L6+L7) \leq$ chargeless length Chargeless length= 10 m (size-down) 30 m (standard) 15 m (size-up) $(L1+L2+L3+L4+L5+L6+L7) >$ chargeless length	You do not have to add additional refrigerant.
	You must add additional refrigerant. For future servicing, encircle the selected amount in the tables below.

INFORMATION

Piping length is the largest one way length of liquid piping.

To determine the additional refrigerant amount (R in kg) (in case of pair)

L1 (standard):	30~40 m	40~50 m	50~60 m ^(a)	60~75 m ^(a)
L1 (size-up):	15~20 m	20~25 m	25~30 m ^(a)	30~35 m ^(a)
R:	0.5 kg	1.0 kg	1.5 kg	2.0 kg

a) Only for RZQG100~140.

To determine the additional refrigerant amount (R in kg) (in case of twin, triple and double twin)

1. Determine G1 and G2.

G1 (m)	Total length of <x> liquid piping x= Ø9.5 mm (standard) x= Ø12.7 mm (size-up)
G2 (m)	Total length of Ø6.4 mm liquid piping

2. Determine R1 and R2.

if	Then
G1>30 m ^(a)	Use the table below to determine R1 (length = G1-30m) ^(a) and R2 (length = G2).
G1≤30 m ^(a) (and G1+G2)	R1=0.0 kg. Use the table below to determine R2 (length = G1+G2-30 m) ^(a) .

a) In case of size-up: Replace 30 m by 15 m.

In case of **standard** liquid pipe size:

	Length			
	0~10 m	10~20 m	20~30 m ^(a)	30~45 m ^(a)
R1:	0.5 kg	1.0 kg	1.5 kg	2.0 kg
R2:	0.3 kg	0.6 kg	0.9 kg	1.2 kg

In case of **size-up** liquid pipe size:

	Length			
	0~5 m	5~10 m	10~15 m ^(a)	15~20 m ^(a)
R1, R2:	0.5 kg	1.0 kg	1.5 kg	2.0 kg

a) Only for RZQG100~140.

3. Determine the additional refrigerant amount: R=R1+R2.

Examples

Layout	Additional refrigerant amount (R)	
	Case: Twin, standard liquid pipe size 1. G1 Total Ø9.5 => G1=35 m G2 Total Ø6.4 => G2=7+5=12 m Case: G1>30 m 2. R1 Length=G1-30 m=5 m=> R1=0.5 kg R2 Length=G2=12 m=> R2=0.6 kg 3. R R=R1+R2=0.5+0.6=1.1 kg	
		Case: Triple, standard liquid pipe size 1. G1 Total Ø9.5 => G1=5 m G2 Total Ø6.4 => G2=20+17+17=54 m Case: G1≤30 m (and G1+G2>30 m) 2. R1 R1=0.0 kg R2 Length=G1+G2-30 m=5+54-30=29 m 3. R R=R1+R2=0.0+0.9=0.9 kg



RZQSG-L3_9V1

Unit combination restrictions		Power supply			COMP		OFM		IFM			
Indoor	Outdoor	1	2	3	MCA	MFA	RHz	RLA	kW	FLA	kW	FLA
2xFNA35A	RZQSG71L3V1B	3N~50Hz	380- 415V	Max. 50Hz 456V Min. 50Hz 342V	19	20	-	16.2	0.07	0.3	2x0.034	2x0.3
2xFNA50A	RZQSG100L9V1B				28.9	32	-	24.2	0.02	0.6	2x0.06	2x0.5
3xFNA50A	RZQSG100L9V1B				28.8	32	-	24.4	0.02	0.6	3x0.034	3x0.3
2xFNA60A	RZQSG125L9V1B				29	32	-	24.4	0.02	0.6	2x0.06	2x0.5
3xFNA50A	RZQSG125L9V1B				29.5	32	-	24.4	0.02	0.6	3x0.06	3x0.5
4xFNA35A	RZQSG125L9V1B				29.2	32	-	24.4	0.02	0.6	4x0.034	4x0.3
3xFNA50A	RZQSG140L9V1B				29.5	32	-	24.2	0.094+0.094	0.4+0.4	3x0.06	3x0.5
4xFNA35A	RZQSG140L9V1B				29.2	32	-	24.2	0.094+0.094	0.4+0.4	4x0.034	4x0.3

Symbols	Notes
1 - HZ 2 - Voltage 3 - Voltage range MCA Minimum Circuit Ampere (A) MFA Maximum Fuse Ampere (A) RLA Rared Load Amps [A] OFM Outdoor Fan Motor IFM Indoor Fan Motor FLA Full Load Ampere (A) kW Fan motor rated output [kW] RHz Rated operating frequency [Hz] COMP Compressor	1 The RLA is based on the following conditions. Indoor temperature 27°C CDB / 19°C CWB. Outdoor temperature 35°C CDB. 2 Select the wire size according to the MCA. 3 The maximum allowable voltage is unbalanced between phases is 2%. 4 Use a circuit breaker instead of a fuse.

RZQSG L3/9V1

3D096315C

RZQSG71-100L3_9V1

Indoor	Outdoor	Power supply	Voltage range	Compressor				OFM		IFM			
				MCA	TOCA	MFA	MSC	RLA	kW	FLA	kW	FLA	
FCAHG125G	RZQSG125L9V1	50Hz 220-240V	Min. 198V Max. 264V	29.3	-	32	-	24.4	0.2	0.06	0.244	1.4	
FCAG35A				x4	29.0	-	32	-	24.4	0.2	0.06	0.044x4	0.3x4
FCAG50A				x3	28.6	-	32	-	24.4	0.2	0.06	0.039x3	0.3x3
FCAG60A				x2	28.3	-	32	-	24.4	0.2	0.06	0.044 x2	0.3x2
FCAG125A					28.8	-	32	-	24.4	0.2	0.06	0.168	1.0
FFA35A				x4	29.5	-	32	-	24.4	0.2	0.06	0.05x4	0.4x4
FFA50A				x3	29.0	-	32	-	24.4	0.2	0.06	0.05 x3	0.4x3
FFA60A				x2	29.0	-	32	-	24.4	0.2	0.06	0.05 x2	0.6x2
FDXM35F3				x4	29.0	-	32	-	24.4	0.2	0.06	0.034 x4	0.3x4
FDXM50F3				x3	29.4	-	32	-	24.4	0.2	0.06	0.06 x3	0.5x3
FDXM60F3				x2	28.8	-	32	-	24.4	0.2	0.06	0.060 x2	0.5x2
FBA35A				x4	33.5	-	32	-	24.4	0.2	0.06	0.140 x4	1.2x4
FBA50A				x3	32.0	-	32	-	24.4	0.2	0.06	0.140 x3	1.2x3
FBA60A				x2	30.3	-	32	-	24.4	0.2	0.06	0.350 x2	1.1x2
FBA125A					30.1	-	32	-	24.4	0.2	0.06	0.350	2.1
FDA125A					30.1	-	32	-	24.4	0.2	0.06	0.350	2.1
FVA125A					29.0	-	32	-	24.4	0.2	0.06	0.238	1.2
FHA35A				x4	30.5	-	32	-	24.4	0.2	0.06	0.060 x4	0.6x4
FHA50A				x3	29.8	-	32	-	24.4	0.2	0.06	0.060 x3	0.6x3
FHA60A				x2	29.0	-	32	-	24.4	0.2	0.06	0.091 x2	0.6x2
FHA125A		29.4	-	32	-	24.4	0.2	0.06	0.150	1.5			
FCAHG71G	x2	28.8	-	32	-	24.4	0.094+0.094	0.4+0.4	0.091x2	0.5x2			
FCAHG140G		29.3	-	32	-	24.4	0.094+0.094	0.4+0.4	0.244	1.4			
FCAG35A	x4	29.0	-	32	-	24.4	0.094+0.094	0.4+0.4	0.044x4	0.3x4			
FCAG50A	x3	28.6	-	32	-	24.4	0.094+0.094	0.4+0.4	0.039x2	0.3x3			
FCAG71A	x2	28.5	-	32	-	24.4	0.094+0.094	0.4+0.4	0.054x2	0.4x2			
FCAG140A		28.8	-	32	-	24.4	0.094+0.094	0.4+0.4	0.168	1.0			
FFA35A	x4	29.5	-	32	-	24.4	0.094+0.094	0.4+0.4	0.05x4	0.4x4			
FFA50A	x3	29.0	-	32	-	24.4	0.094+0.094	0.4+0.4	0.05x3	0.4x3			
FDXM35F3	x2	29.0	-	32	-	24.4	0.094+0.094	0.4+0.4	0.034x4	0.3x4			
FDXM50F3	x3	29.4	-	32	-	24.4	0.094+0.094	0.4+0.4	0.06x3	0.5x3			
FBA35A	x4	33.5	-	32	-	24.4	0.094+0.094	0.4+0.4	0.140x4	1.2x4			
FBA50A	x3	32.0	-	32	-	24.4	0.094+0.094	0.4+0.4	0.140x3	1.2x3			
FBA71A	x2	30.3	-	32	-	24.4	0.094+0.094	0.4+0.4	0.350x2	1.1x2			
FBA140A		30.1	-	32	-	24.4	0.094+0.094	0.4+0.4	0.350	2.1			
FAA71A	x2	28.5	-	32	-	24.4	0.094+0.094	0.4+0.4	0.048 x2	0.4x2			
FVA140A		29.3	-	32	-	24.4	0.094+0.094	0.4+0.4	0.276	1.4			
FHA35A	x4	30.5	-	32	-	24.4	0.094+0.094	0.4+0.4	0.060 x4	0.6x4			
FHA50A	x3	29.8	-	32	-	24.4	0.094+0.094	0.4+0.4	0.060 x3	0.6x3			
FHA71A	x2	29.5	-	32	-	24.4	0.094+0.094	0.4+0.4	0.091 x2	0.8x2			
FHA140A		29.8	-	32	-	24.4	0.094+0.094	0.4+0.4	0.15	1.8			

Notes	Symbols
MCA Min. Circuit Amps. (A) TOCA Total Over-Current Amps. (A) MFA Max. Fuse Amps (See note 7) (A) MSC Max. current during the starting compressor. (A) RLA Rated Load Amps. (A) OFM Outdoor Fan Motor. (A) IFM Indoor Fan Motor. FLA Full Load Amps. kW Fan Motor Rated Output (kW)	1 RLA is based on the following indoor conditions: Power supply: 50Hz 400V Cooling Indoor temperature 27.0°CDB/19.0°CWB Outdoor temperature 35.0°CDB Heating Indoor temperature 20.0°CDB Outdoor temperature 7.0°CDB/6.0°CWB. 2 TOCA means the total value of each OC set. 3 Voltage range Units are suitable for use on electrical systems where voltage supplied to unit terminals is not below or above listed range limits. 4 Maximum allowable voltage variation between phases is 2% . 5 MCA represents maximum input current, MFA represents capacity which may accept MCA. (next lower standard fuse rating, min.15A). 6 Select wire size based on the larger value of MCA or TOCA. 7 MFA is used to select the circuit breaker and the ground fault circuit interrupter. (earth leakage circuit breaker)

RZQSG71-100L3_9V1

3D090679



Detailed technical drawings

RZQSG71-100L3_9V1

Unit combination restrictions		Power supply			COMP			OFM		IFM		
Indoor	Outdoor	1	2	3	MCA	MFA	RHz	RLA	kW	FLA	kW	FLA
2xFBA60A	RZQSG125L9V1B	50	220- 240V	Max. 50Hz 264V Min. 50Hz 198V	29	32	-	24,4	0,2	0,6	2x0,07	2x0,5
3xFBA50A	RZQSG125L9V1B				29,8	32	-	24,4	0,2	0,6	3x0,089	3x0,6
4xFBA35A	RZQSG125L9V1B				30,4	32	-	24,4	0,2	0,6	4x0,089	4x0,6
FBA140A	RZQSG140L9V1B				29,5	32	74	24,2	0,094+0,094	0,4+0,4	0,187	1,5
2xFBA71A	RZQSG140L9V1B				29	32	-	24,2	0,094+0,094	0,4+0,4	2x0,07	2x0,5
3xFBA50A	RZQSG140L9V1B				29,8	32	-	24,2	0,094+0,094	0,4+0,4	3x0,089	3x0,6
4xFBA35A	RZQSG140L9V1B				30,4	32	-	24,2	0,094+0,094	0,4+0,4	4x0,089	4x0,6

Symbols	Notes
1 - HZ 2 - Voltage 3 - Voltage range MC Minimum Circuit Ampere (A) MFA Maximum Fuse Ampere (A) RLA Rared Load Amps [A] OFM Outdoor Fan Motor IFM Indoor Fan Motor FLA Full Load Ampere (A) kW Fan motor rated output [kW] RHz Rated operating frequency [Hz] COMP Compressor	1 The RLA is based on the following conditions. Indoor temperature 27°CDB / 19°CWB. Outdoor temperature 35°CDB. 2 Select the wire size according to the MCA. 3 The maximum allowable voltage is unbalanced between phases is 2%. 4 Use a circuit breaker instead of a fuse.

RZQSG125-140L9V1

3D094863B

RZQSG71-100L3_9V1

Indoor	Outdoor	Power supply	Voltage range	MCA	TOCA	MFA	Compressor		OFM		IFM					
							MSC	RLA	kW	FLA	kW	FLA				
FCAHG71G		RZQSG71L3V1	50Hz 220-240V	Min. 198V Max. 264V	18.8	-	20	-	16.2	0.7	0.3	0.091	0.5			
FCAG35A	X2				18.9	-	20	-	16.2	0.7	0.3	0.044x2	0.3x2			
FCAG71A					18.7	-	20	-	16.2	0.7	0.3	0.054	0.4			
FFA35A	x2				19.2	-	20	-	16.2	0.7	0.3	0.050x2	0.4x2			
FDXM35F3	x2				18.9	-	20	-	16.2	0.7	0.3	0.034x2	0.3x1			
FBA35A	x2				21.2	-	25	-	16.2	0.7	0.3	0.140x2	1.2x2			
FBA71A					19.5	-	20	-	16.2	0.7	0.3	0.350	1.1			
FAA71A					18.7	-	20	-	16.2	0.7	0.3	0.048	0.4			
FVA71A					18.9	-	20	-	16.2	0.7	0.3	0.117	0.6			
FHA35A	x2				19.1	-	20	-	15.7	0.7	0.3	0.060x2	0.6x2			
FHA71A					18.6	-	20	-	15.7	0.7	0.3	0.091	0.8			
FCAHG100G					RZQSG100L9V1	50Hz 220-240V	Min. 198V Max. 264V	29.1	-	32	-	24.4	0.2	0.6	0.221	1.3
FCAG35A	x3							28.6	-	32	-	24.4	0.2	0.6	0.044x3	0.3x3
FCAG50A	x2							28.3	-	32	-	24.4	0.2	0.6	0.039x2	0.3x2
FCAG100A		28.4	-	32				-	24.4	0.2	0.6	0.117	0.7			
FFA35A	x3	29.0	-	32				-	24.4	0.2	0.6	0.05x3	0.4x3			
FFA50A	x2	28.5	-	32				-	24.4	0.2	0.6	0.05x2	0.4x2			
FDXM35F3	x3	28.6	-	32				-	24.4	0.2	0.6	0.034x3	0.3x3			
FDXM50F3	x2	28.8	-	32				-	24.4	0.2	0.6	0.06x2	0.5x2			
FBA35A	x3	32.0	-	40				-	24.4	0.2	0.6	0.140x3	1.2x3			
FBA50A	x2	30.5	-	32				-	24.4	0.2	0.6	0.140x2	1.2x2			
FBA100A		29.5	-	32				-	24.4	0.2	0.6	0.350	1.6			
FAA100A		28.0	-	32				-	24.4	0.2	0.6	0.064	0.4			
FVA100A		29.0	-	32				-	24.4	0.2	0.6	0.238	1.2			
FHA35A	x3	29.8	-	32				-	24.4	0.2	0.6	0.060x3	0.6x3			
FHA50A	x2	29.0	-	32	-	24.4	0.2	0.6	0.060x2	0.6x2						
FHA100A		29.1	-	32	-	24.4	0.2	0.6	0.150	1.3						

Symbols	Notes
MCA Min. Circuit Amps. (A) TOCA Total Over-Current Amps. (A) MFA Max. Fuse Amps (See note 7) (A) MSC Max. current during the starting compressor. (A) RLA Rated Load Amps. (A) OFM Outdoor Fan Motor. (A) IFM Indoor Fan Motor. FLA Full Load Amps. kW Fan Motor Rated Output (kW)	1 RLA is based on the following indoor conditions: Power supply: 50Hz 400V Cooling Indoor temperature 27.0°CDB/19.0°CWB Outdoor temperature 35.0°CDB Heating Indoor temperature 20.0°CDB Outdoor temperature 7.0°CDB/6.0°CWB. 2 TOCA means the total value of each OC set. 3 Voltage range Units are suitable for use on electrical systems where voltage supplied to unit terminals is not below or above listed range limits. 4 Maximum allowable voltage variation between phases is 2% . 5 MCA represents maximum input current, MFA represents capacity which may accept MCA. (next lower standard fuse rating, min.15A). 6 Select wire size based on the larger value of MCA or TOCA. 7 MFA is used to select the circuit breaker and the ground fault circuit interrupter. (earth leakage circuit breaker)

RZQSG71-100L3_9V1

3D090679



RZQSG71L3V1

Indoor	Outdoor	Power supply	Voltage range	MCA	TOCA	MFA	Compressor		OFM		IFM	
							MSC	RLA	kW	FLA	kW	FLA
FCAHG71G		50Hz 220-240V	Min. 198V Max. 264V	18.8	-	20	-	16.2	0.07	0.3	0.091	0.5
FCAG35A	x2			18.9	-	20	-	16.2	0.07	0.3	0.044x2	0.3x2
FCAG71A				18.7	-	20	-	16.2	0.07	0.3	0.054	0.4
FFA35A	x2			19.2	-	20	-	16.2	0.07	0.3	0.055x2	0.4x2
FFA35A	x2			18.9	-	20	-	16.2	0.07	0.3	0.050x2	0.3x2
FBA35A	x2			21.2	-	20	-	16.2	0.07	0.3	0.140x2	1.2x2
FBA71A				19.5	-	20	-	16.2	0.07	0.3	0.350	1.1
FHA35A	x2			19.7	-	20	-	16.2	0.07	0.3	0.062x2	0.6x2
FCAHG71G				19.2	-	20	-	16.2	0.07	0.3	0.091	0.8
FAA71A				18.7	-	20	-	16.2	0.07	0.3	0.048	0.4
FVA71A				18.9	-	20	-	16.2	0.07	0.3	0.117	0.6
FFA71A	x2			19.2	-	20	-	16.2	0.07	0.3	0.050x2	0.4x2
FDXM35F3	x2			18.9	-	20	-	16.2	0.07	0.3	0.034x2	0.3x2

Symbols

MCA	Min. Circuit Amps. (A)
TOCA	Total Over-Current Amps. (A)
MFA	Max. Fuse Amps (See note 7) (A)
MSC	Max. current during the starting compressor. (A)
RLA	Rated Load Amps. (A)
OFM	Outdoor Fan Motor. (A)
IFM	Indoor Fan Motor.
FLA	Full Load Amps.
kW	Fan Motor Rated Output (kW)

Notes

- RLA is based on the following indoor conditions:
Power supply: 50Hz 400V
Cooling
Indoor temperature 27.0°CDB/19.0°CWB
Outdoor temperature 35.0°CDB
Heating
Indoor temperature 20.0°CDB
Outdoor temperature 7.0°CDB/6.0°CWB.
- TOCA means the total value of each OC set.
- Voltage range
Units are suitable for use on electrical systems where voltage supplied to unit terminals is not below or above listed range limits.
- Maximum allowable voltage variation between phases is 2%.
- MCA represents maximum input current, MFA represents capacity which may accept MCA. (next lower standard fuse rating, min.15A).
- Select wire size based on the larger value of MCA or TOCA.
- MFA is used to select the circuit breaker and the ground fault circuit interrupter. (earth leakage circuit breaker)

RZQSG71L3V1

3D082372A



RZQSG71L3V1

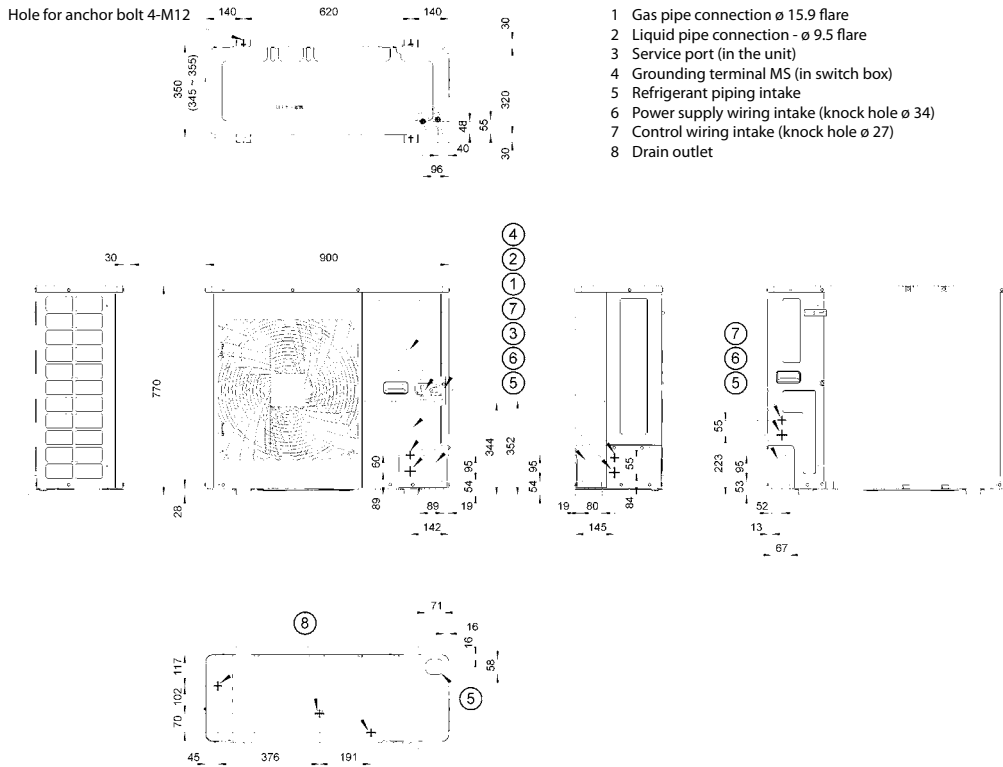

3D082346

RZQSG100-125L9V1/L8Y1

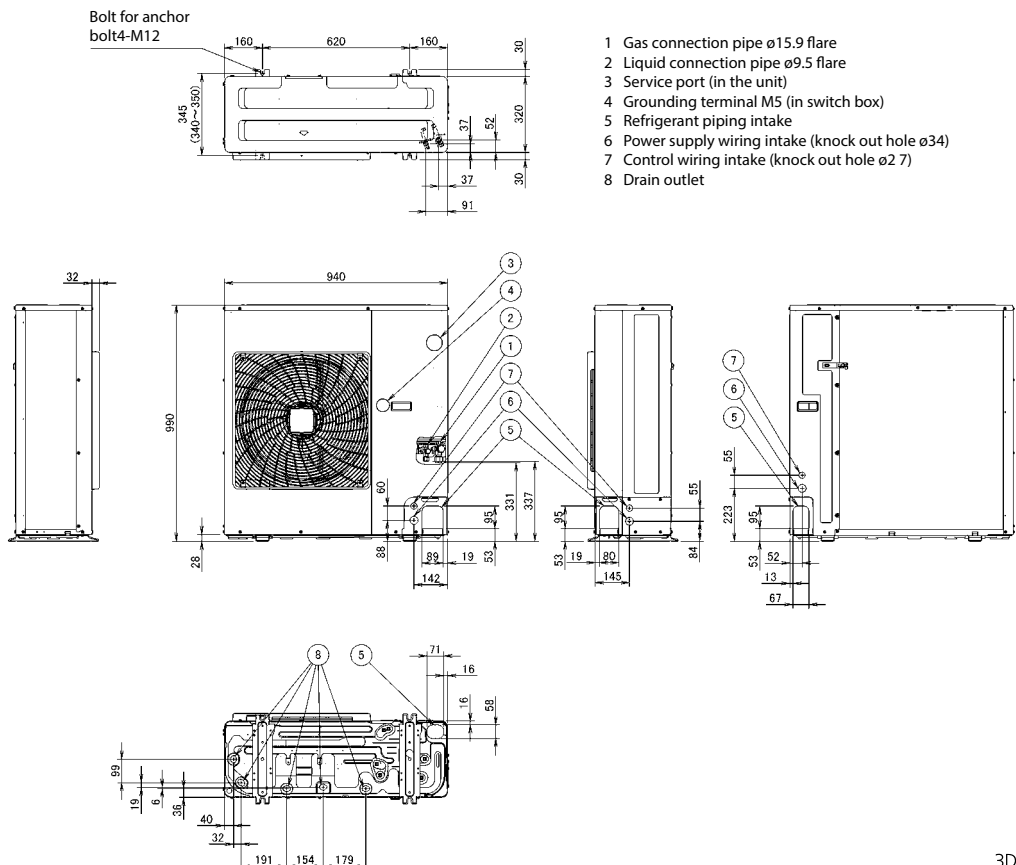

3D076345



RZQSG140LY1

- 1 Gas connection pipe $\varnothing 15.9$ flare
- 2 Liquid connection pipe $\varnothing 9.5$ flare
- 3 Service port (in the unit)
- 4 Grounding terminal M5 (in switch box)
- 5 Refrigerant piping intake
- 6 Power supply wiring intake (knock out hole $\varnothing 34$)
- 7 Control wiring intake (knock out hole $\varnothing 27$)
- 8 Drain outlet

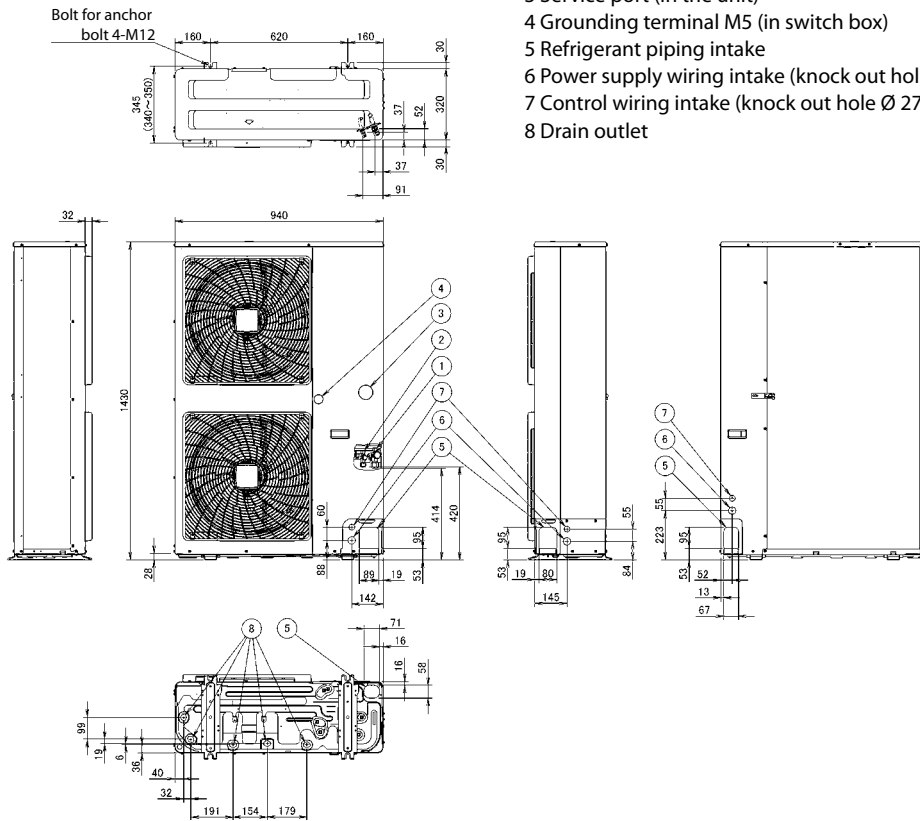

3D076346



Detailed technical drawings

RZQSG71L3V1

A. Non stacked installation

		←	→	↖	↗	↘	A	B1	B2	C	D1	D2	E	L1/L2	
	✓							≥50(100)							
	✓						≥100	≥100		≥100					
	✓							≥100					≥1000		
	✓						≥150	≥150		≥100			≥1000		
		✓										≥500			
		✓		✓								≥500		≥1000	
	✓	✓						L1<L2	≥50(100)		≤500		≥500		
								L2<L1	≥50(100)				≥500		
								L1<L2	L1≤H	≥150(100)	≤200		≥750		0<L1≤1/2H
									H<L1				≥1000		0<L1≤1/2H
	✓		✓	✓			≥200	≥200(300)		≥1000					
	✓		✓	✓	✓		≥200	≥200(300)		≥1000		≤500	≥1000		
		✓										≥1000			
		✓		✓						≤500		≥1000		≥1000	
	✓	✓						L1<L2	≥200(300)			≥1000			
								L2<L1	≥150(250)			≥1000		0<L2≤1/2H	
									≥200(300)			≥1000		1/2H<L2≤H	
								L1<L2	L1<L2	≥200(300)	≤500		≥1000		0<L1≤1/2H
									H<L1			≥1250		≥1000	1/2H<L2≤H

Legend (Unit:mm)

←	→	↖	↗	↘	✓
Suction side obstacle	Discharge side obstacle	Left side obstacle	Right side obstacle	Top side obstacle	Obstacle is present

- In these cases, close the bottom of the installation frame to prevent discharged air from being bypassed.
 - In these cases, only 2 units can be installed.
- ✗ This situation is not allowed.

Figures between () indicate the dimensions only for the 100-125-140 class models.

B. Stacked installation

1. Obstacles exist in front of the outlet side

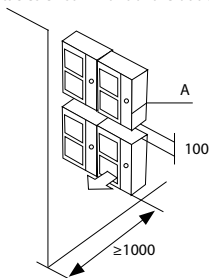

2. Obstacles exist in front of the air inlet

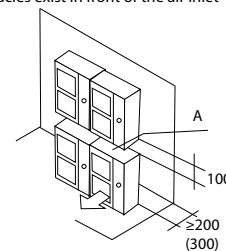

Do not stack more than one unit.
About 100mm is required as the dimension for laying the upper outdoor unit's drain pipe.
Get the portion A sealed so that air from the outlet does not bypass.

C. Multiple-row installation

1. Installation of one unit per row

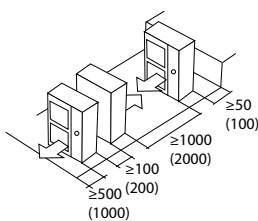

2. Installing multiple units (2 units or more) in lateral connection per row

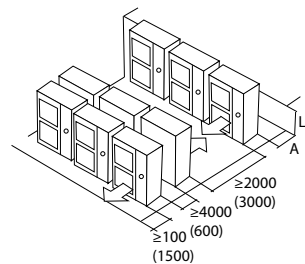

Relation of dimensions of H, A, and L are shown in the table below.

	L	A
L ≤ H	0 < L ≤ 1/2 H	150 (250)
H > L	1/2 H < L	200 (300)
	Installation impossible	



RZQSG100-140L9V1

Installation service space

The measure of these values is "mm".

(A) When there are obstacles on suction sides.

• No obstacle above

- ① Stand-alone installation
 - Obstacle on the suction side only

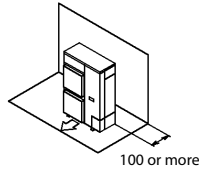

• Obstacle on both sides and suction side, too

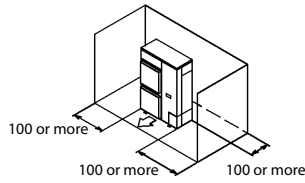

- ② Series installation (2 or more) (Note 1)
 - Obstacle on the suction side and both sides

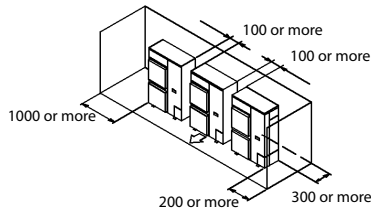

• Obstacle above, too

- ① Stand-alone installation
 - Obstacle on the suction side, too

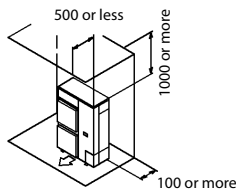

• Obstacle on both sides and suction side, too

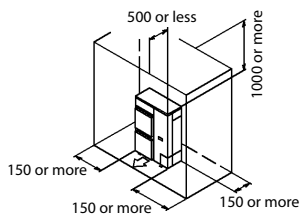

- ② Series installation (2 or more) (Note 1)
 - Obstacle on the suction side and both sides

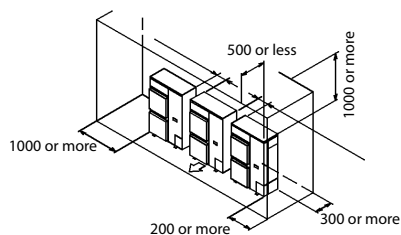

(B) When there are obstacles on discharge sides.

• No obstacle above

- ① Stand-alone installation
 - Obstacle on the discharge side only

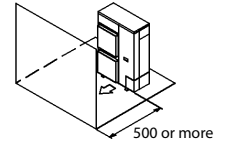

- ② Series installation (2 or more) (Note 1)
 - Obstacle on the discharge side only

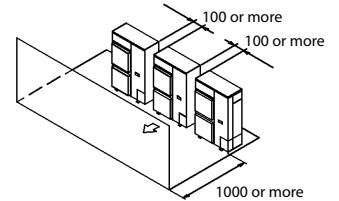

• Obstacle above, too.

- ① Stand-alone installation
 - Obstacle on the discharge side only, too

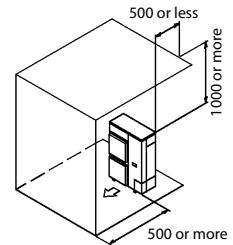

- ② Series installation (2 or more) (Note 1)
 - Obstacle on the discharge side

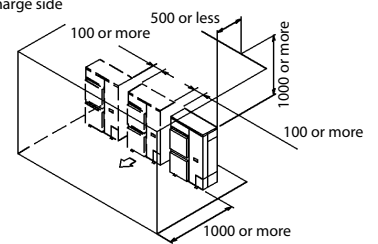

(C) When there are obstacles on both suction and discharge sides:

Pattern 1

When the obstacles on the discharge side is higher than the unit. (L>H)
(There is no limit for the height of obstructions on the suction side.)

• No obstacle above

- ① Stand-alone installation
 - No obstacle above

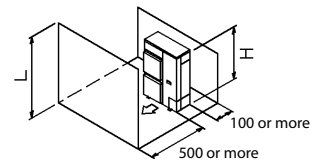

- ② Series installation (2 or more) (Note 1)
 - No obstacle above

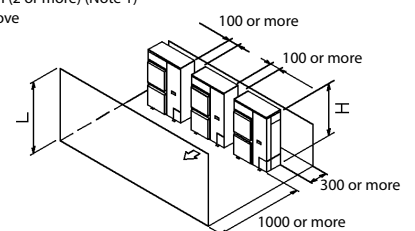



Detailed technical drawings

RZQSG100-140L9V1

- **Obstacle above, too**
- ① Stand-alone installation (Note 2)
- When there are obstacles on suction, discharge and top sides.

The relations between H, A and L are as follows.

	L	A
$L \leq H$	$L \leq 1/2H$	750 or more
	$1/2 H < L \leq H$	1000 or more
$L > H$	Set the stand as: $L \leq H$ Refer to the column of $L \leq H$ for A	

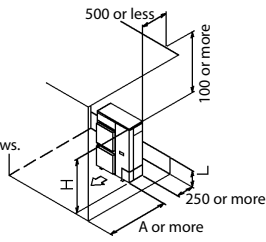

- ② Series installation (2 or more) (Note 1, 2)
- When there are obstacles on suction, discharge and top sides.

The relations between H, A and L are as follows.

	L	A
$L \leq H$	$L \leq 1/2H$	250 or more
	$1/2 H < L \leq H$	300 or more
$L > H$	Set the stand as: $L \leq H$ Refer to the column of $L \leq H$ for A	

Limit of series installation is 2 units.

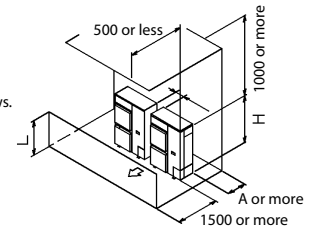

- ② Series installation (Note 1,2)
- When there are obstacles on suction, discharge and top sides.

The relations between H, A and L are as follows.

	L	A
$L \leq H$	$L \leq 1/2H$	1000 or more
	$1/2 H < L \leq H$	1250 or more
$L > H$	Set the stand as: $L \leq H$ Refer to the column of $L \leq H$ for A	

Limit of series installation is 2 units.

Pattern 2

When the obstacle on the discharge side is lower than the unit ($L \leq H$) (There is no limit for the height of obstructions on the suction side.)

- **No obstacle above**
- ① Stand-alone installation
- No obstacle above

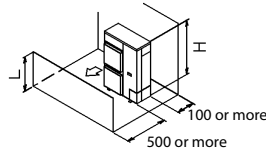

- ② Series installation (2 or more) (Note 1, 2)
- When there are obstacles on both suction and discharge sides.

The relations between H, A and L are as follows.

	L	A
$L \leq 1/2H$		250 or more
$1/2 H < L \leq H$		300 or more

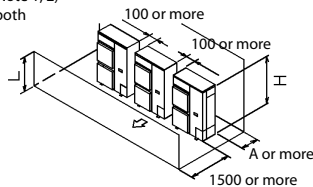

- **Obstacle above, too**
- ① Stand-alone installation (Note 2)
- When there are obstacles on suction, discharge and top sides

The relations between H, A and L are as follows.

	L	A
$L \leq H$	$L \leq 1/2H$	100 or more
	$1/2 H < L \leq H$	200 or more
$L > H$	Set the stand as: $L \leq H$ Refer to the column of $L \leq H$ for A	

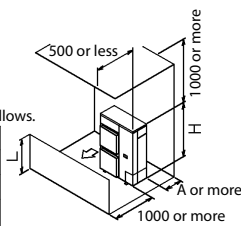

(D) Double-decker installation

- ① Obstacle on the discharge side. (Note 1)
- Do not exceed two levels for stacked installation.
- Install a roof cover similar to A (field supply), as outdoor units with downward drainage are prone to dripping and freezing.
- Install the upper-level outdoor unit so that its bottom plate is a sufficient height above the roof cover. This is to prevent the buildup of ice on the underside of the bottom plate.

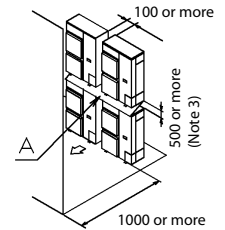

- ② Obstacle on the suction side. (Note 1)
- Do not exceed two levels for stacked installation.
- Install a roof cover similar to A (field supply), as outdoor units with downward drainage are prone to dripping and freezing.
- Install the upper-level outdoor unit so that its bottom plate is a sufficient height above the roof cover. This is to prevent the buildup of ice on the underside of the bottom plate.

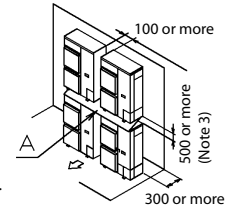

(E) Multiple rows of series installation (on the rooftop, etc.)

- ① One row of stand-alone installation

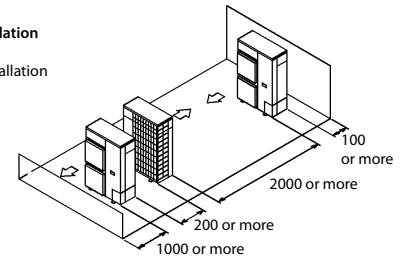

- ② Rows of series installation (2 or more)

The relations between H, A and L are as follows.

	L	A
$L \leq H$	$L \leq 1/2H$	250 or more
	$1/2 H < L \leq H$	300 or more
$L > H$	Can not be installed	

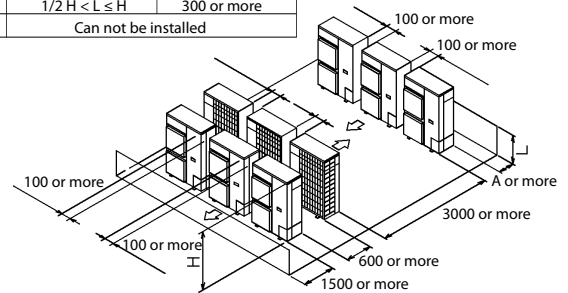

Notes

- 1 In case of the sideways's piping, make a 100mm gap between the unit above.
- 2 Close the bottom of the installation frame to prevent the discharged air from being bypassed.
- 3 It is not necessary to install a roof cover if there is no danger of drainage dripping and freezing. In this case, the space between the upper and lower outdoor units should be at least 100mm. Close off the gap between the upper and lower units so there is no re-intake of discharged air.



AZQS-B(8)V1

Indoor	Outdoor	Power supply	Voltage range	MCA	TOCA	MFA	Compressor		OFM		IFM			
							MSC	RLA	kW	FLA	kW	FLA		
ACQ71DV1	AZQS71B2V1B	50Hz ~ 220-240V	Min. 198V Max. 264V	18.8	-	20	-	16.2	0.07	0.3	0.067	0.52		
ABQ71CV1	AZQS71B2V1B			19.5	-	20	-	16.2	0.07	0.3	0.128	1.05		
AHQ71CV1	AZQS71B2V1B			19.2	-	20	-	16.2	0.07	0.3	0.106	0.8		
ACQ100DV1	AZQS100B8V1B			28.5	-	32	-	24.4	0.2	0.6	0.094	0.77		
ABQ100CV1	AZQS100B8V1B			28.6	-	32	-	24.4	0.2	0.6	0.109	0.9		
AHQ100CV1	AZQS100B8V1B			28.9	-	32	-	24.4	0.2	0.6	0.149	1.12		
ACQ125DV1	AZQS100B8V1B			21.5	-	32	-	24.4	0.2	0.6	0.137	1.12		
ABQ125CV1	AZQS100B8V1B			31.5	-	32	-	24.4	0.2	0.6	0.413	3.16		
AHQ125CV1	AZQS100B8V1B			28.9	-	32	-	24.4	0.2	0.6	0.240	1.1		
ABQ140CV1	AZQS140B8V1B			32.8	-	40	-	24.2	0.094+0.094	0.4+0.4	0.546	4.23		
AHQ140CV1	AZQS140B8V1B			30.7	-	32	-	24.2	0.094+0.094	0.4+0.4	0.316	2.52		
ACQ140DV1	AZQS140B8V1B			28.9	-	32	-	24.2	0.094+0.094	0.4+0.4	0.137	1.12		
ACQ100DV1	AZQS100B7Y1B			3N~50Hz 380-415V	Min. 342V Max. 456V	14.2	-	11.4	-	11.4	0.2	0.6	0.094	0.77
ABQ100CV1	AZQS100B7Y1B					14.3	-	11.4	-	11.4	0.2	0.6	0.109	0.9
AHQ100CV1	AZQS100B7Y1B	14.6	-			11.4	-	11.4	0.2	0.6	0.149	1.12		
ACQ125DV1	AZQS125B7Y1B	14.6	-			11.4	-	11.4	0.2	0.6	0.137	1.12		
ABQ125CV1	AZQS125B7Y1B	17.2	-			11.4	-	11.4	0.2	0.6	0.413	3.16		
AHQ125CV1	AZQS125B7Y1B	14.6	-			11.4	-	11.4	0.2	0.6	0.240	1.10		
ABQ140CV1	AZQS140B7Y1B	21.8	-			14.2	-	14.2	0.094+0.094	0.4+0.4	0.546	4.23		
AHQ140CV1	AZQS140B7Y1B	19.7	-			14.2	-	14.2	0.094+0.094	0.4+0.4	0.316	2.52		
ACQ140DV1	AZQS140B7Y1B	17.9	-			14.2	-	14.2	0.094+0.094	0.4+0.4	0.137	1.12		

Symbols

- MCA Min. Circuit Amps. (A)
- TOCA Total Over-Current Amps. (A)
- MFA Max. Fuse Amps (See note 7) (A)
- MSC Max. current during the starting compressor. (A)
- RLA Rated Load Amps. (A)
- OFM Outdoor Fan Motor. (A)
- IFM Indoor Fan Motor.
- FLA Full Load Amps.
- kW Fan Motor Rated Output (kW)

Notes

- 1 RLA is based on the following indoor conditions:
Cooling
Indoor temperature 27.0°CDB/19.0°CWB
Outdoor temperature 35.0°CDB
Heating
Indoor temperature 20.0°CDB
Outdoor temperature 7.0°CDB/6.0°CWB.
- 2 TOCA is the total value of each overcurrent set.
- 3 Voltage range
The units are suitable for use with electrical systems in which the voltage supplied to the unit terminals is not below or above the listed range limits
- 4 Maximum allowable voltage variation between phases is 2%.
- 5 MCA is the maximum input current.
The capacity of the MFA must be greater than that of the MCA.
Select the MFA according to the table.
- 6 Select the wire size according to the MCA.
- 7 MFA is used to select the circuit breaker and the ground fault circuit interrupter.
(earth leakage circuit breaker)

AZQS-B(8)V1 AZQS-BY1

3D090681B

AZQS71B2V1

unit (mm)

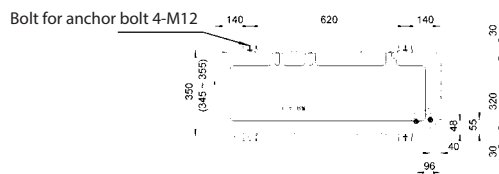

- KA Gas pipe connection Ø 15.9 flare
- KB Liquid pipe connection Ø 15.9 flare
- KC Service port (in the unit)
- KD Grounding terminal M5 (in switch box)
- KE Refrigerant piping intake
- KF Power supply wiring intake (knock hole Ø 34)
- KG Control wiring intake (knock hole Ø 34)
- KH Drain outlet

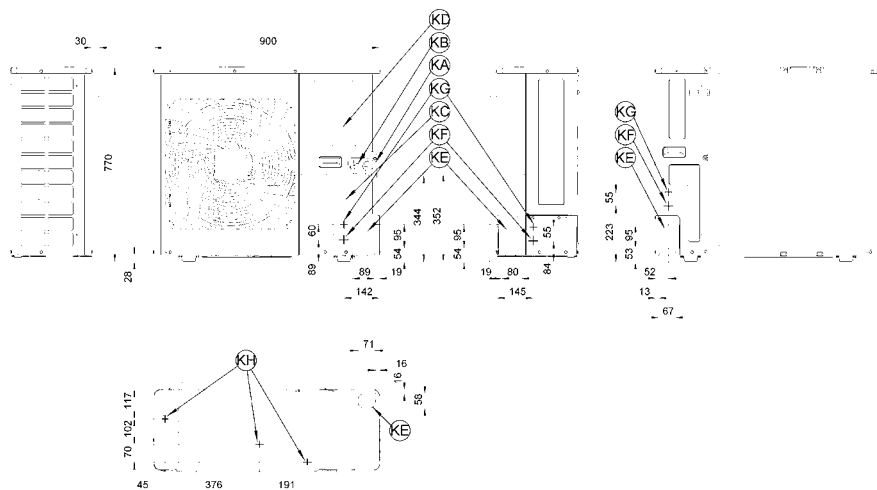

3D081307



AZQS100-125B8V1/BY1

Bolt for anchor bolt 4-M12

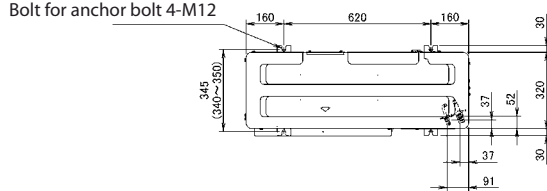

- 1 Gas pipe connection Ø 15.9 flare
- 2 Liquid pipe connection Ø 9.5 flare
- 3 Service port (in the unit)
- 4 Grounding terminal M5 (in switch box)
- 5 Refrigerant piping intake
- 6 Power supply wiring intake (knock hole Ø 34)
- 7 Control wiring intake (knock hole Ø 34)
- 8 Drain outlet

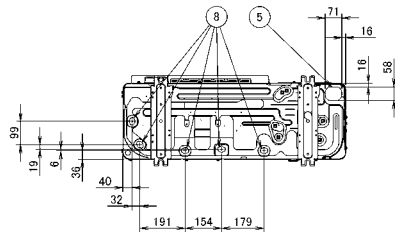
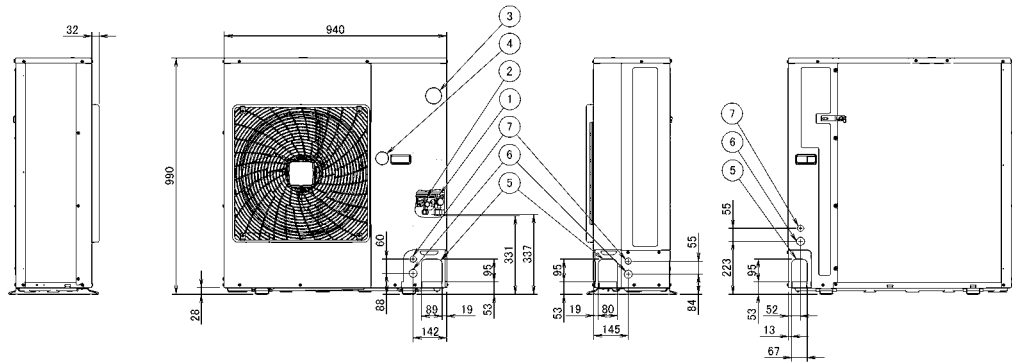

3D076345

AZQS140B8V1/BY1

Bolt for anchor bolt 4-M12

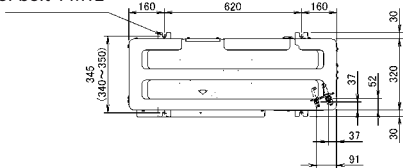

- 1 Gas pipe connection Ø 15.9 flare
- 2 Liquid pipe connection Ø 9.5 flare
- 3 Service port (in the unit)
- 4 Grounding terminal M5 (in switch box)
- 5 Refrigerant piping intake
- 6 Power supply wiring intake (knock hole Ø 34)
- 7 Control wiring intake (knock hole Ø 27)
- 8 Drain outlet

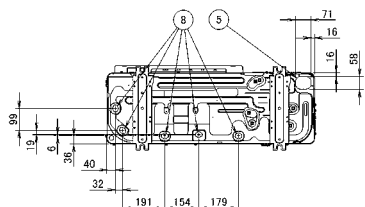
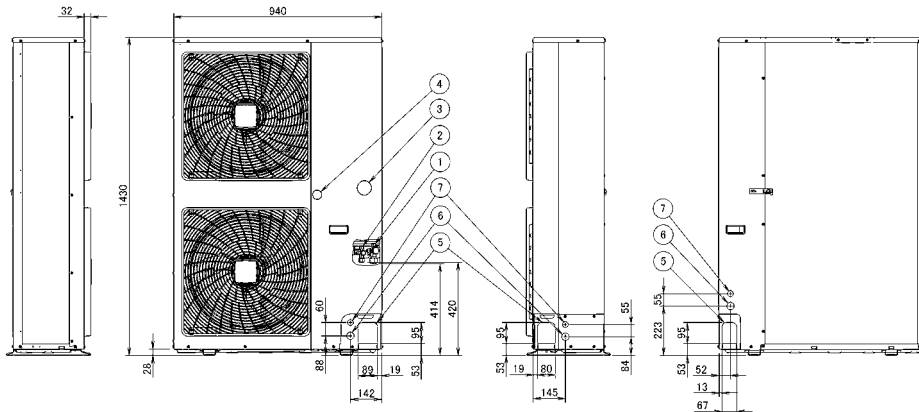

3D076346



AZQS-B8V1/BY1

Installation service space

The measure of these values is "mm".

(A) When there are obstacles on suction sides.

• No obstacle above

- ① Stand-alone installation
 - Obstacle on the suction side only

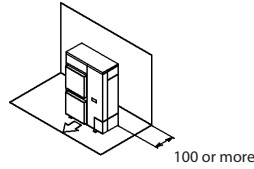

- Obstacle on both sides and suction side, too

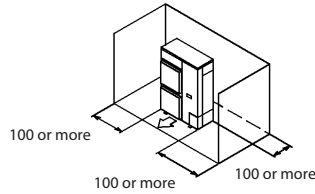

- ② Series installation (2 or more) (Note 1)
 - Obstacle on the suction side and both sides

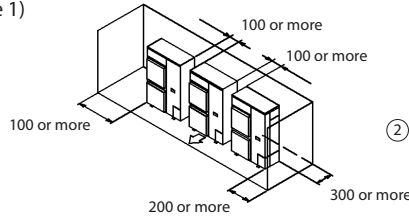

• Obstacle above, too.

- ② Stand-alone installation
 - Obstacle on the suction side, too

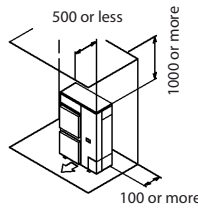

- Obstacle on both sides and suction side, too

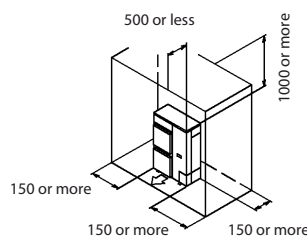

- ② Series installation (2 or more) (Note 1)
 - Obstacle on the suction side and both sides

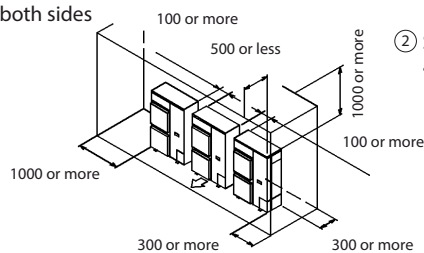

(A) When there are obstacles on discharge sides.

• No obstacle above

- ① Stand-alone installation
 - Obstacle on the discharge side only
- ② Series installation (2 or more) (Note 1)
 - Obstacle on the suction side only

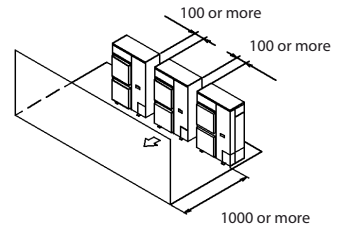
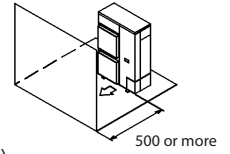

• Obstacle above, too.

- ① Stand-alone installation
 - Obstacle on the discharge side only, too

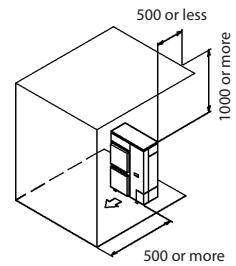

- ② Series installation (2 or more) (Note 1)
 - Obstacle on discharge side

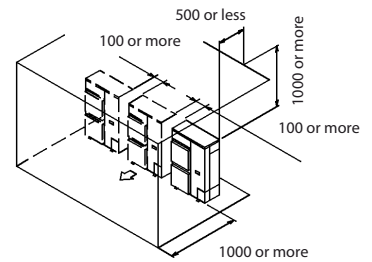

(C) When there are obstacles on both suction and discharge sides:

Pattern 1

When the obstacles on the discharge side is higher than the unit. ($L > H$)
(There is no limit for the height of obstructions on the suction side.)

• No obstacle above

- ① Stand-alone installation
 - No obstacle above

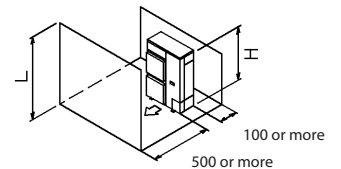

- ② Series installation (2 or more) (Note 1)
 - No obstacle above

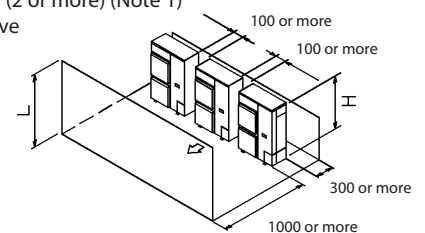

AZQS-B8V1/BY1

• Obstacle above, too

- ① Stand-alone installation (Note 2)
 - When there are obstacles on suction, discharge and top sides.

	L	A
$L \leq H$	$L \leq 1/2 H$	750 or more
	$1/2 H < L \leq H$	1000 or more
$L > H$	Set the stand as: $L \leq H$ Refer to the column of $L \leq H$ for A	

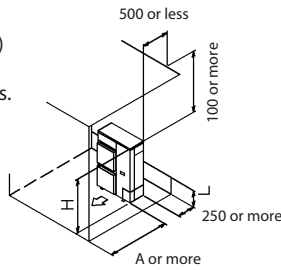

- ② Series installation (2 or more) (Note 1,2)
 - When there are obstacles on suction, discharge and top sides.

The relations between H, A and L are as follows.

	L	A
$L \leq H$	$L \leq 1/2 H$	250 or more
	$1/2 H < L \leq H$	300 or more
$L > H$	Set the stand as: $L \leq H$ Refer to the column of $L \leq H$ for A	

Limit of series installation is 2 units.

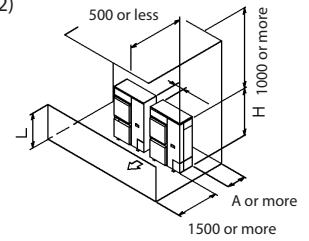

- ② Series installation (2 or more) (Note 1,2)

- When there are obstacles on suction, discharge and top sides.

The relations between H, A and L are as follows.

	L	A
$L \leq H$	$L \leq 1/2 H$	1000 or more
	$1/2 H < L \leq H$	1250 or more
$L > H$	Set the stand as: $L \leq H$ Refer to the column of $L \leq H$ for A	

Limit of series installation is 2 units.

Pattern 2

When the obstacle on the discharge side is lower than the unit ($L \leq H$) (There is no limit for the height of obstructions on the suction side.)

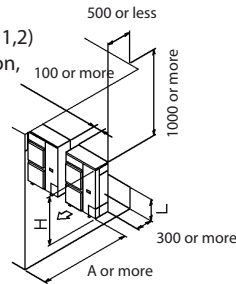

• No obstacle above

- ① Stand-alone installation
 - No obstacle above

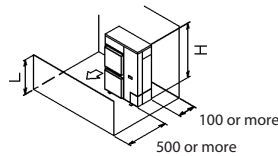

- ② Series installation (2 or more) (Note 1,2)

- When there are obstacles on both suction and discharge sides.

The relations between H, A and L are as follows.

	L	A
$L \leq 1/2 H$		250 or more
$1/2 H < L \leq H$		300 or more

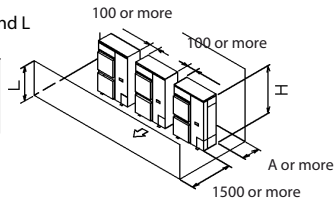

• No obstacle above

- ① Stand-alone installation (Note 2)
 - When there are obstacles on suction, discharge and top sides.

The relations between H, A and L are as follows.

	L	A
$L \leq H$	$L \leq 1/2 H$	100 or more
	$1/2 H < L \leq H$	200 or more
$L > H$	Set the stand as: $L \leq H$ Refer to the column of $L \leq H$ for A	

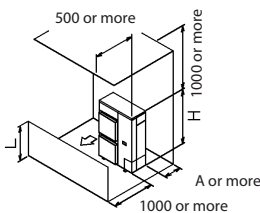

(D) Double-decker installation

- ① Obstacle on the discharge side. (1)

- Do not exceed two levels for stacked installation.
- Install a roof cover similar to A (field supply), as outdoor units with downward drainage are prone to dripping and freezing.
- Install the upper-level outdoor unit so that its bottom plate is a sufficient height above the roof cover. This is to prevent the buildup of ice on the underside of the bottom plate.

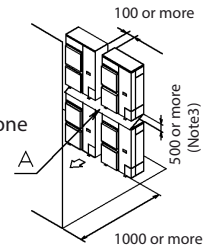

- ② Obstacle on the suction side. (1)

- Do not exceed two levels for stacked installation.
- Install a roof cover similar to A (field supply), as outdoor units with downward drainage are prone to dripping and freezing.
- Install the upper-level outdoor unit so that its bottom plate is a sufficient height above the roof cover. This is to prevent the buildup of ice on the underside of the bottom plate.

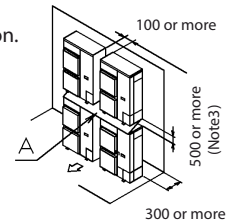

(E) Multiple rows of series installation (on the rooftop, etc.)

- ① One row of stand-alone installation

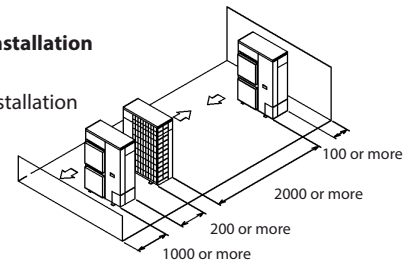

- ② Rows of series installation (2 or more)

The relations between H, A and L are as follows.

	L	A
$L \leq H$	$L \leq 1/2 H$	250 or more
	$1/2 H < L \leq H$	300 or more
$L > H$	Can not be installed	

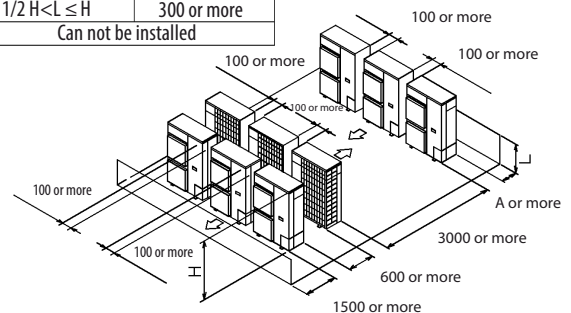

NOTES

- In case of the sideways's piping, make a 100mm gap between the unit above.
- Close the bottom of the installation frame to prevent the discharged air from being bypassed.
- It is not necessary to install a roof cover if there is no danger of drainage dripping and freezing. In this case, the space between the upper and lower outdoor units should be at least 100mm. Close off the gap between the upper and lower units so there is no reintake of discharged air.



RZQ-C

Unit combination			Power supply				Comp.		OFM		IFM	
Indoor unit	Outdoor unit	HZ-volts	Voltage range	MCA	TOCA	MCA	MSC	RLA	kW	FLA	kW	FLA
FFA50A X4	RZQ200C7Y1B	50-400		Max.50Hz415V Min. 50Hz380V	16.8	-	25	-	13.3	0.75	0.7	0.055X4
FFA60A X3	RZQ200C7Y1B	50-400	16.1		-	20	-	13.3	0.75	0.7	0.055X3	0.7X3
FBA5AA X4	RZQ200C7Y1B	50-400	16.8		-	25	-	13.3	0.75	0.7	0.085X4	0.7X4
FBA60A X3	RZQ200C7Y1B	50-400	16.7		-	25	-	13.3	0.75	0.7	0.125X3	0.9X3
FBA71A X3	RZQ200C7Y1B	50-400	16.7		-	25	-	13.3	0.75	0.7	0.125X3	0.9X3
FBA100A X2	RZQ200C7Y1B	50-400	16.0		-	20	-	13.3	0.75	0.7	0.135X2	1.0X2
FHA50A X4	RZQ200C7Y1B	50-400	16.4		-	20	-	13.3	0.75	0.7	0.062X4	0.6X4
FHA60A X3	RZQ200C7Y1B	50-400	15.8		-	20	-	13.3	0.75	0.7	0.062X3	0.6X3
FHA71A X3	RZQ200C7Y1B	50-400	15.8		-	20	-	13.3	0.75	0.7	0.062X3	0.6X3
FUA100A X2	RZQ200C7Y1B	50-400	15.4		-	20	-	13.3	0.75	0.7	0.130X2	0.7X2
FAA71A X3	RZQ200C7Y1B	50-400	16.1		-	20	-	13.3	0.75	0.7	0.045X3	0.7X3
FUA100A X2	RZQ200C7Y1B	50-400	16.2		-	20	-	13.3	0.75	0.7	0.090X2	1.1X2
FAA71A X3	RZQ200C7Y1B	50-400	14.9		-	20	-	13.3	0.75	0.7	0.043X3	0.3X3
FAA100A X2	RZQ200C7Y1B	50-400	14.8		-	20	-	13.3	0.75	0.7	0.049X2	0.4X2
FDQ200B7V3B	RZQ200C7Y1B	50-400	14.0		-	20	-	13.3	0.75	0.7	0.650	6.8
FFA60A X4	RZQ250C7Y1B	50-400	16.8		-	25	-	13.3	0.75	0.7	0.055X4	0.7X4
FFA60A X4	RZQ250C7Y1B	50-400	17.6		-	25	-	13.3	0.75	0.7	0.125X4	0.9X4
FBA125A X4	RZQ250C7Y1B	50-400	16.8		-	25	-	13.3	0.75	0.7	0.225X2	1.4X2
FHA60A X4	RZQ250C7Y1B	50-400	16.4		-	20	-	13.3	0.75	0.7	0.062X4	0.6X4
FHA125A X2	RZQ250C7Y1B	50-400	15.4		-	20	-	13.3	0.75	0.7	0.130X2	0.7X2
FUA125A X2	RZQ250C7Y1B	50-400	16.2		-	20	-	13.3	0.75	0.7	0.090X2	1.1X2
FDA125A X2	RZQ250C7Y1B	50-400	14.0		-	20	-	13.3	0.75	0.7	0.500X2	4.2X2
FDQ250B7V3B X2	RZQ250C7Y1B	50-400	14.0		-	20	-	13.3	0.75	0.7	1.000	7.6
FCAHG71G X3	RZQ200C7Y1B	50-400	17.3		-	20	-	13.3	0.75	0.7	0.091X3	0.5 X3
FCAHG100G X2	RZQ200C7Y1B	50-400	18.7		-	20	-	13.3	0.75	0.7	0.211X2	1.3 X2
FCAG50A X4	RZQ200C7Y1B	50-400	16.9		-	20	-	13.3	0.75	0.7	0.039X4	0.3 X4
FCAG60A X3	RZQ200C7Y1B	50-400	16.5		-	20	-	13.3	0.75	0.7	0.044X3	0.3X3
FCAG71A X3	RZQ200C7Y1B	50-400	16.9		-	20	-	13.3	0.75	0.7	0.048X3	0.4X3
FCAG100A X2	RZQ200C7Y1B	50-400	17.2		-	20	-	13.3	0.75	0.7	0.117X2	0.7X2
FHA50A X4	RZQ200C7Y1B	50-400	17.9		-	20	-	13.3	0.75	0.7	0.060X4	0.5X4
FHA60A X3	RZQ200C7Y1B	50-400	17.3		-	20	-	13.3	0.75	0.7	0.091X3	0.5 X3
FHA71A X3	RZQ200C7Y1B	50-400	18.4		-	20	-	13.3	0.75	0.7	0.091X3	0.8 X3
FHA100A X2	RZQ200C7Y1B	50-400	18.4		-	20	-	13.3	0.75	0.7	0.150X2	1.2X2
FUA71A X3	RZQ200C7Y1B	50-400	18.0		-	20	-	13.3	0.75	0.7	0.046X3	0.7 X3
FUA100A X3	RZQ200C7Y1B	50-400	17.9		-	20	-	13.3	0.75	0.7	0.106X2	1.0 X2
FAA71A X2	RZQ200C7Y1B	50-400	16.9		-	20	-	13.3	0.75	0.7	0.048X3	0.4 X3
FAA100A X2	RZQ200C7Y1B	50-400	16.4		-	20	-	13.3	0.75	0.7	0.064X2	0.4 X2
FCAHG125G X2	RZQ250C7Y1B	50-400	18.9		-	20	-	13.3	0.75	0.7	0.224X2	1.4X2
FCAG60A X4	RZQ250C7Y1B	50-400	16.9		-	20	-	13.3	0.75	0.7	0.044X4	0.3X4
FCAG125A X2	RZQ250C7Y1B	50-400	18.2		-	20	-	13.3	0.75	0.7	0.106X2	1.1X2
FHA60A X2	RZQ250C7Y1B	50-400	17.9		-	20	-	13.3	0.75	0.7	0.091X4	0.5X4
FHA125A X2	RZQ250C7Y1B	50-400	19.4		-	20	-	13.3	0.75	0.7	0.150X2	1.6X2
FUA125A X2	RZQ250C7Y1B	50-400	18.2		-	20	-	13.3	0.75	0.7	0.106X2	1.1 X2

Symbols	Notes
<p>MCA Min. Circuit Amps. (A)</p> <p>TOCA Total Over-Current Amps. (A)</p> <p>MFA Max. Fuse Amps (See note 7) (A)</p> <p>MSC Max. current during the starting compressor. (A)</p> <p>RLA Rated Load Amps. (A)</p> <p>OFM Outdoor Fan Motor. (A)</p> <p>IFM Indoor Fan Motor.</p> <p>FLA Full Load Amps.</p> <p>kW Fan Motor Rated Output (kW)</p>	<p>1 RLA is based on the following indoor conditions: Power supply: 50Hz 400V Cooling Indoor temperature 27.0°CDB/19.0°CWB Outdoor temperature 35.0°CDB Heating Indoor temperature 20.0°CDB Outdoor temperature 7.0°CDB/6.0°CWB.</p> <p>2 TOCA means the total value of each OC set.</p> <p>3 Voltage range Units are suitable for use on electrical systems where voltage supplied to unit terminals is not below or above listed range limits.</p> <p>4 Maximum allowable voltage variation between phases is 2% .</p> <p>5 MCA represents maximum input current, MFA represents capacity which may accept MCA. (next lower standard fuse rating, min. 15A).</p> <p>6 Select wire size based on the larger value of MCA or TOCA.</p> <p>7 MFA is used to select the circuit breaker and the ground fault circuit interrupter. (earth leakage circuit breaker)</p>

RZQ-C

3D056844E

RZQ-C

Unit combination restrictions		Power supply				COMP		OFM		IFM		
Indoor	Outdoor	1	2	3	MCA	MFA	RHz	RLA	kW	FLA	kW	FLA
3xFBA60A	RZQ200C7Y1B	3N~ 50Hz	400V	MAX. 50Hz	15.5	20	-	13.3	0.75	0.7	3x0.07	3x0.5
4xFBA50A	RZQ200C7Y1B			415V	16.4	20	-	13.3	0.75	0.7	4x0.089	4x0.6
2xFBA125A	RZQ250C7Y1B			Min. 50Hz	17	20	-	13.3	0.75	0.7	2x0.187	2x1.5
4xFBA60A	RZQ250C7Y1B			380V	16	20	-	13.3	0.75	0.7	4x0.07	4x0.5

Symbols	Notes
<p>1 - HZ</p> <p>2 - Voltage</p> <p>3 - Voltage range</p> <p>MCA Minimum Circuit Ampere (A)</p> <p>MFA Maximum Fuse Ampere (A)</p> <p>RLA Rated Load Amps [A]</p> <p>OFM Outdoor Fan Motor</p> <p>IFM Indoor Fan Motor</p> <p>FLA Full Load Ampere (A)</p> <p>kW Fan motor rated output [kW]</p> <p>RHz Rated operating frequency [Hz]</p> <p>COMP Compressor</p>	<p>1 The RLA is based on the following conditions. Indoor temperature 27°CDB / 19°CWB. Outdoor temperature 35°CDB.</p> <p>2 Select the wire size according to the MCA.</p> <p>3 The maximum allowable voltage is unbalanced between phases is 2%.</p> <p>4 Use a circuit breaker instead of a fuse.</p>

RZQ-C

3D 094863B



Detailed technical drawings

RZQ-C

Unit combination restrictions		Power supply					COMP		OFM		IFM	
Indoor	Outdoor	1	2	3	MCA	MFA	RHz	RLA	kW	FLA	FLA	FLA
3xFNA60A	RZQ200C7Y1B	3N~ 50Hz	400V	MAX. 50Hz 415V Min. 50Hz 380V	15.5	20	-	13.3	0.75	0.7	3x0.06	3x0.5
4xFNA50A	RZQ200C7Y1B				16	20	-	13.3	0.75	0.7	4x0.06	4x0.5
4xFNA60A	RZQ250C7Y1B				16	20	-	13.3	0.75	0.7	4x0.06	4x0.5

Symbols	Notes
1 - HZ 2 - Voltage 3 - Voltage range MCA Minimum Circuit Ampere (A) MFA Maximum Fuse Ampere (A) RLA Rared Load Amps [A] OFM Outdoor Fan Motor IFM Indoor Fan Motor FLA Full Load Ampere (A) kW Fan motor rated output [kW] RHz Rated operating frequency [Hz] COMP Compressor	1 The RLA is based on the following conditions. Indoor temperature 27° CDB / 19° CWB. Outdoor temperature 35° CDB. 2 Select the wire size according to the MCA. 3 The maximum allowable voltage is unbalanced between phases is 2%. 4 Use a circuit breaker instead of a fuse.

RZQ-C

3D094863B

RZQ200C

Unit combination restrictions		Power supply					COMP		OFM		IFM	
Indoor	Outdoor	1	2	3	MCA	MFA	RHZ	RLA	kW	FLA	kW	FLA
2xFBA100A	RZQ200C7y1b	3N~ 50Hz	400V	MAX. 50Hz 415V MIN. 50Hz 380V	16	20	-	13.3	0.75	0.7	2x0.127	2x1
3xFBA71A	RZQ200C7y1b				15.5	20	-	13.3	0.75	0.7	4x0.06	3x0.5

Symbols	Notes
1 - HZ 2 - Voltage 3 - Voltage range MCA Minimum Circuit Ampere (A) MFA Maximum Fuse Ampere (A) RLA Rared Load Amps [A] OFM Outdoor Fan Motor IFM Indoor Fan Motor FLA Full Load Ampere (A) kW Fan motor rated output [kW] RHz Rated operating frequency [Hz] COMP Compressor	1 The RLA is based on the following conditions. Indoor temperature 27° CDB / 19° CWB. Outdoor temperature 35° CDB. 2 Select the wire size according to the MCA. 3 The maximum allowable voltage is unbalanced between phases is 2%. 4 Use a circuit breaker instead of a fuse.

RZQ200C

3D094863B



RZQ200-250C

	Unit combination		Minimum Ssc value [kVA]
FCAG50A	x4	RZQ200C7Y1B	-
FCAG60A	x3	RZQ200C7Y1B	-
FCAG71A	x3	RZQ200C7Y1B	-
FCAG100A	x2	RZQ200C7Y1B	-
FFA50A	x4	RZQ200C7Y1B	1025
FFA60A	x3	RZQ200C7Y1B	1025
FBA50A	x4	RZQ200C7Y1B	1025
FBA60A	x3	RZQ200C7Y1B	1025
FBA71A	x3	RZQ200C7Y1B	1025
FBA100A	x2	RZQ200C7Y1B	-
FHA50A	x4	RZQ200C7Y1B	1025
FHA60A	x3	RZQ200C7Y1B	-
FHA71A	x3	RZQ200C7Y1B	-
FHA100A	x2	RZQ200C7Y1B	-
FUA71A	x3	RZQ200C7Y1B	1025
FUA100A	x2	RZQ200C7Y1B	1025
FAA71A	x3	RZQ200C7Y1B	-
FAA100A	x2	RZQ200C7Y1B	-
FDQ200B7V3B	x1	RZQ200C7Y1B	-
FCAG60A	x4	RZQ250C7Y1B	-
FCAG125A	x2	RZQ250C7Y1B	-
FFA60A	x4	RZQ250C7Y1B	1025
FBA60A	x4	RZQ250C7Y1B	1025
FBA125A	x2	RZQ250C7Y1B	1025
FHA60A	x4	RZQ250C7Y1B	1025
FHA125A	x2	RZQ250C7Y1B	-
F UA125A	x2	RZQ250C7Y1B	1025
FDA125A	x2	RZQ250C7Y1B	-
FDQ250B7V3B	x1	RZQ250C7Y1B	-

NOTES

- In accordance with EN/IEC 61000-3-12*, it may be necessary to consult the distribution network operator to ensure that the equipment is connected only to a supply with $S_{sc}^{**} \geq$ minimum Ssc value.
- (*) European/international technical standard setting the limits for harmonic currents produced by equipment connected to public low-voltage system with input current $>16A$ and $\leq 75A$ per phase.
- (**) Short-circuit power

RZQ200-250C

4TW29041



Detailed technical drawings

RZQ200-250C

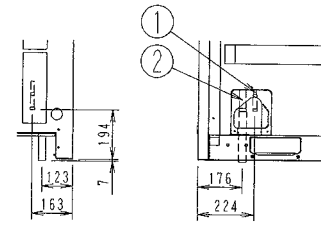
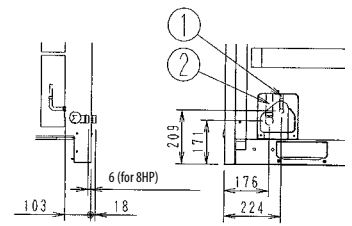
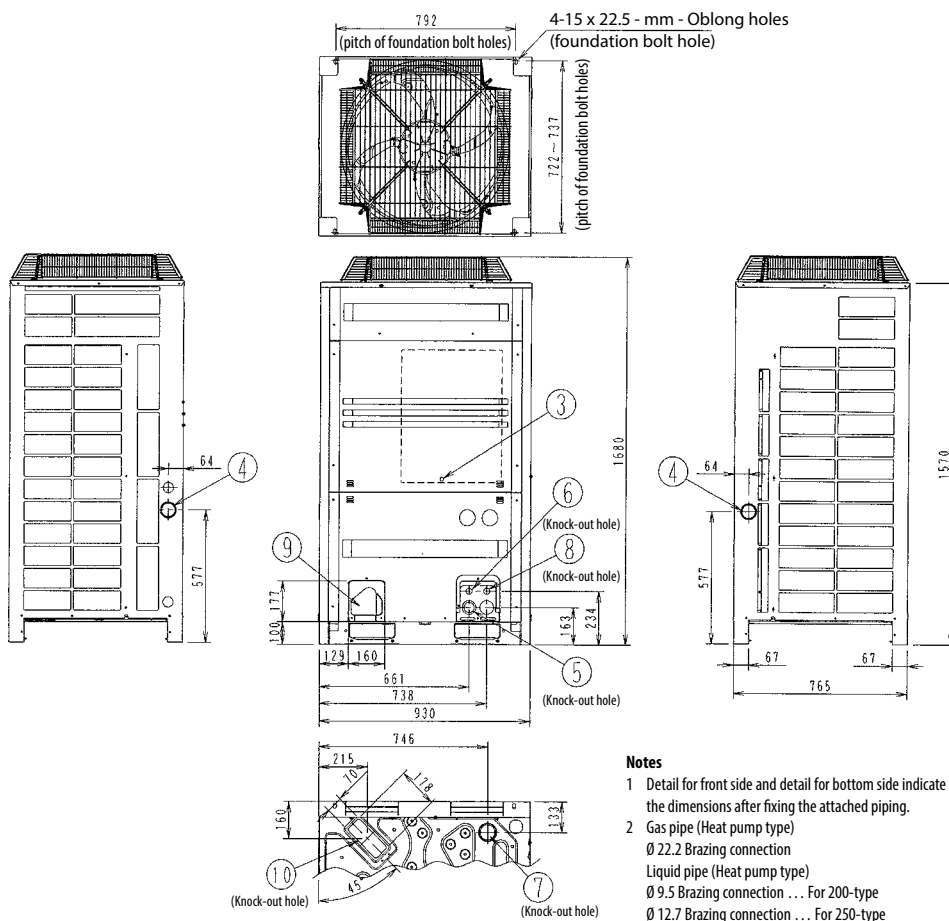

- Notes**
- 1 Detail for front side and detail for bottom side indicate the dimensions after fixing the attached piping.
 - 2 Gas pipe (Heat pump type)
Ø 22.2 Brazing connection
Liquid pipe (Heat pump type)
Ø 9.5 Brazing connection ... For 200-type
Ø 12.7 Brazing connection ... For 250-type

- 1 Liquid pipe connection port see note 2
- 2 Gas pipe connection port see note 2
- 3 Grounding terminal inside of switch box (M8)
- 4 Power cord routing hole (side) Ø 62
- 5 Power cord routing hole (front) Ø 45
- 6 Power cord routing hole (front) Ø 27
- 7 Power cord routing hole (bottom) Ø 65.5
- 8 Wire routing hole (front) Ø 27
- 9 Pipe routing hole (front)
- 10 Pipe routing hole (bottom)

3TW29044-1

RZQ200-250C

For single unit installation
<Pattern 1>

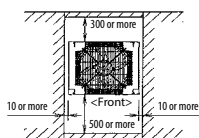

For installation in rows
<Pattern 1>

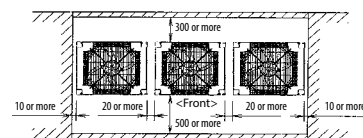

For centralized group layout
<Pattern 1>

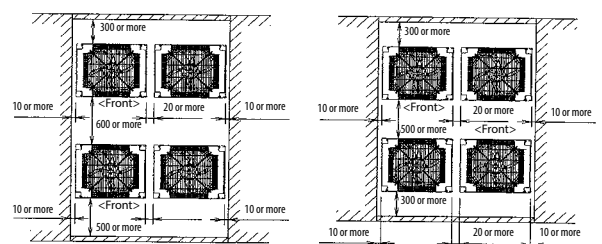

<Pattern 2>

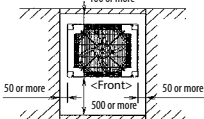

<Pattern 2>

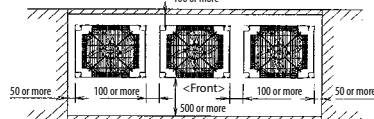

<Pattern 2>

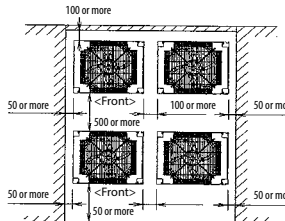

<Pattern 2>

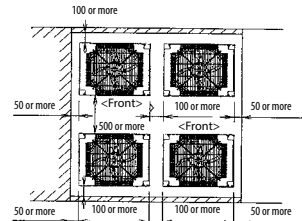

<Unit:mm>

Notes:

1. Heights of walls in case of Patterns 1 and 2:
Front: 1 500 mm
suction side: 500 mm
Side: Height unrestricted.
Installation space to be shown in this drawing is based on the cooling operation at 35 degrees outdoor air temperature.
When the design outdoor air temperature exceeds 35 degrees or the load exceeds maximum ability because of much generation load of heat in all outdoor unit take the suction side space more broadly than the space to be shown in this drawing.
2. If the above wall heights are exceeded then h 1/2 and h2/2 should be added to the front and suction side service spaces respectively as shown in the figure on the right.
3. When installing the units most appropriate pattern should be selected from those shown above in order to obtain the best fit in the space available always bearing in mind the need to leave enough space for a person to pass between units and wall and for the air to circulate freely. (If more units are to be installed than are catered for in the above patterns your layout should take account of the possibility of short circuits.)
4. The units should be installed to leave sufficient space at the front for the on site refrigerant piping work to be carried out comfortably.

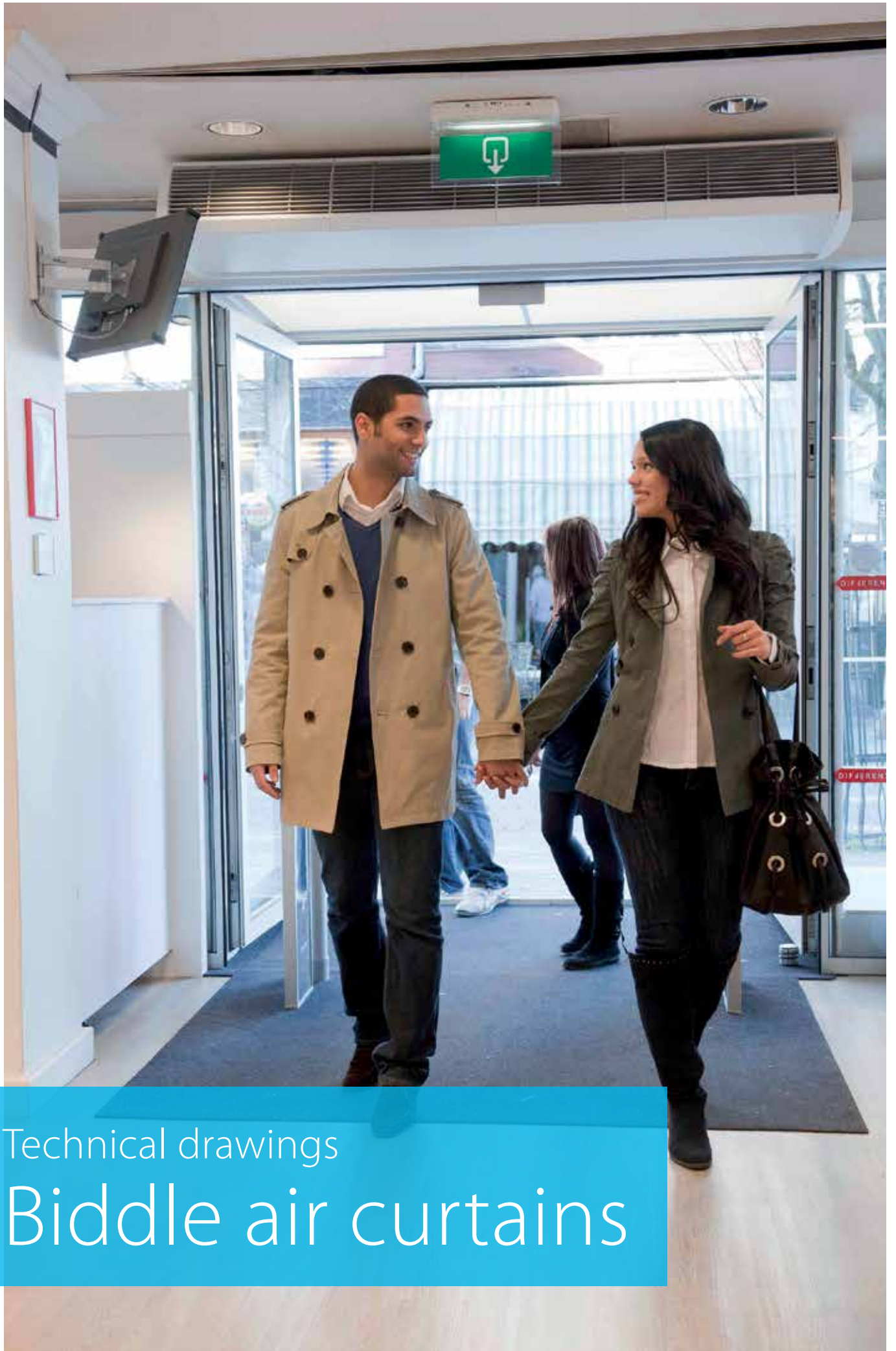

Technical drawings
Biddle air curtains



CYQS_M_L-DK_FBN_FSN

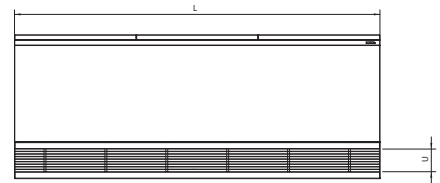
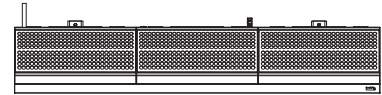
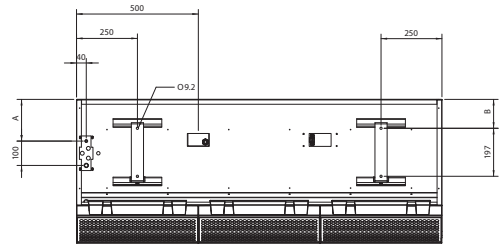
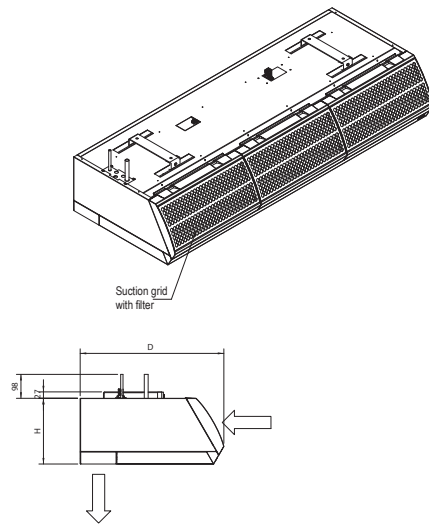

Type	L	H	D	U	A	B
CYQS-DK-FBN/FSN	1,000 - 1,500	270	590	93	171	119
CYQM-DK-FBN/FSN	2,000 - 2,500					
CYQL-DK-FBN/FSN	1,000 - 1,500	370	774	124.5	245.5	200
	2,000 - 2,500					

CU0954X-000

REMARKS

- The 2,500mm large devices have 3 suspension brackets, where the third bracket is mounted at half the length of the device.

CYQS_M_L-DK_CBN_CSN

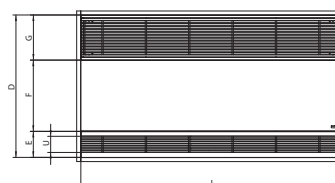
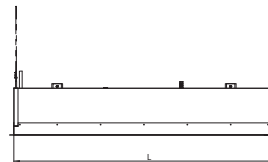
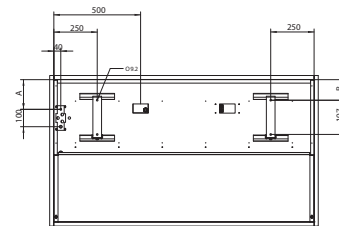
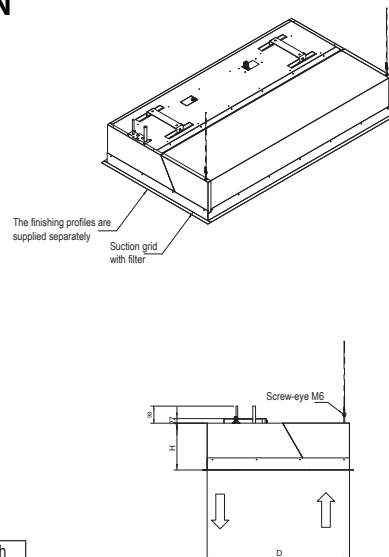

Number of suction grids per device

Device length	Number	Suction grid length
1000 / 1500	1	1,000 / 1,500
2000 / 2500	2	1,000 / 1,250

*1 drain grid per device

Type	L	H	D	U	A	B	E	F	G
CYQS-DK-CBN/CSN	1,000 - 1,500	270	821	93	171	119	250	411	260
CYQM-DK-CBN/CSN	2,000 - 2,500								
CYQL-DK-CBN/CSN	1,000 - 1,500	370	1,105	124.5	245.5	200	181.5	563.5	360
	2,000 - 2,500								

CU0955X-000

REMARKS

- The 2,500mm large devices have 3 suspension brackets, where the third bracket is mounted at half the length of the device.
- The mounting holes for finishing profiles in a lowered ceiling (L+8) x (D+8) mm



CYQS_M_L-DK_RBN_RSN

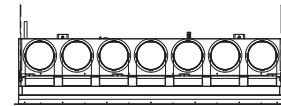
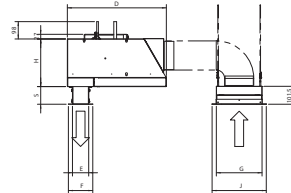
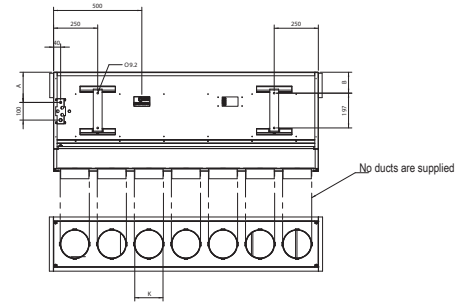
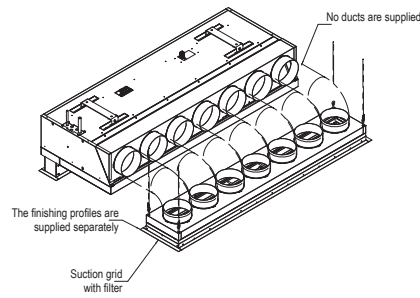

Number of ducts per device

Type	1000	1500	2000	2500
CYQS-DK-RBN/RSN	5	7	10	12
CYQM-DK-RBN/RSN	3	5	6	8

Number of suction grids per device

Device length	Number	Suction grid length
1000 / 1500	1	1,000 / 1,500
2000 / 2500	2	1,000 / 1,250

*1 drain grid per device

Type	L	H	D	S	U	A	B	E	F	G	J	K	M	T
CYQS-DK-RBN/RSN	1,000 - 1,500	270	561	80-125	90	171	119	92	139	260	308	Ø160	1044-1544 2044-2544	1048-1548 2048-2548
CYQM-DK-RBN/RSN	1,000 - 1,500 2,000 - 2,500	370	745	80-125	121.5	245.5	200	123.5	170	360	408	Ø250	1044-1544 2044-2544	1048-1548 2048-2548

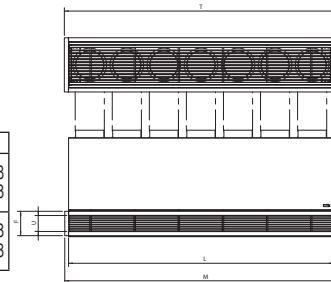

CU0956X-000

REMARKS

- 1 The 2,500mm large devices have 3 suspension brackets, where the third bracket is mounted at half the length of the device.
- 2 Holes (for finishing profiles) - drain (L+8) x (E+8) mm - suction (L+8) x (G+8) mm.

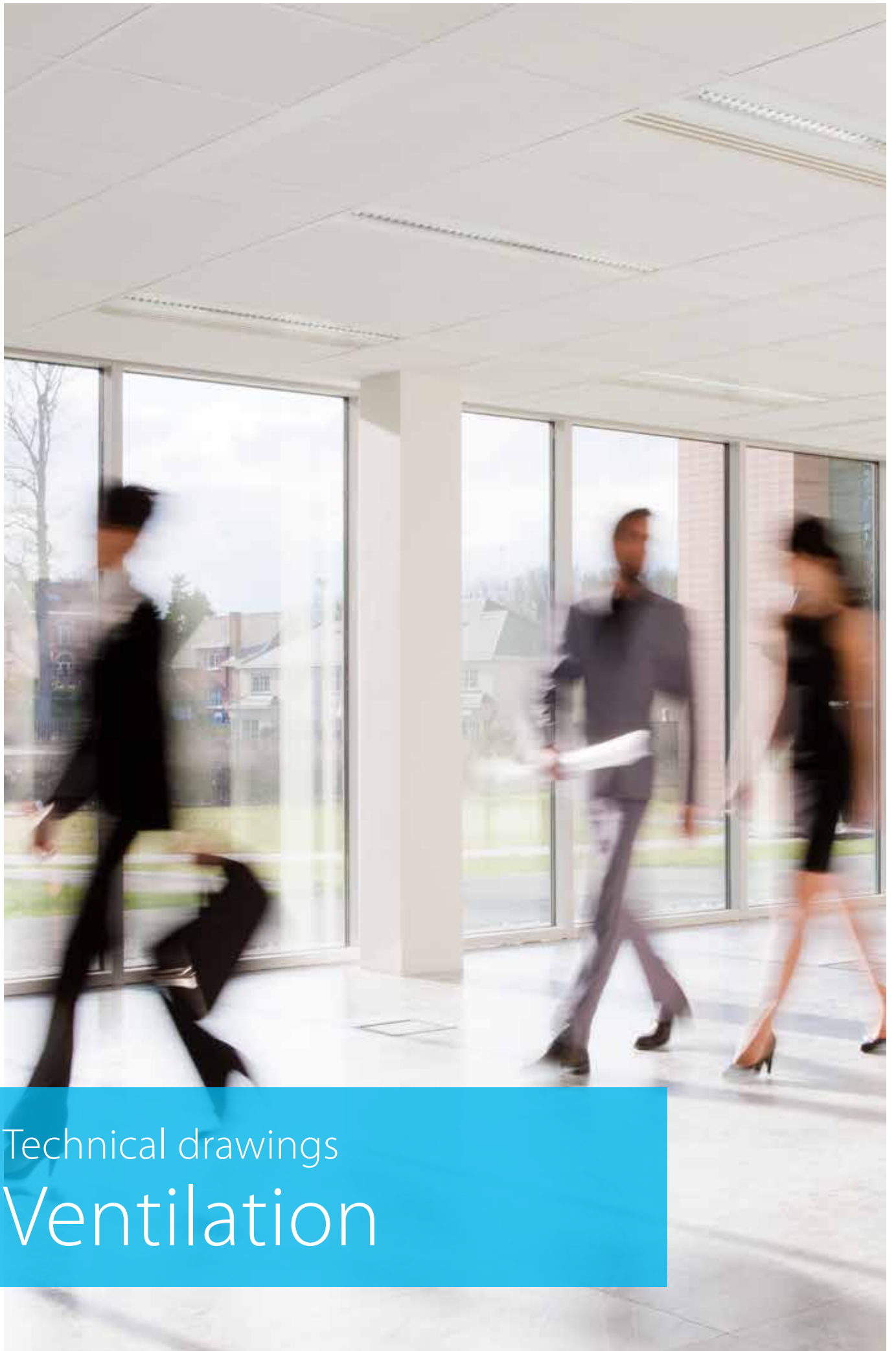

Technical drawings
Ventilation



VAM150FC

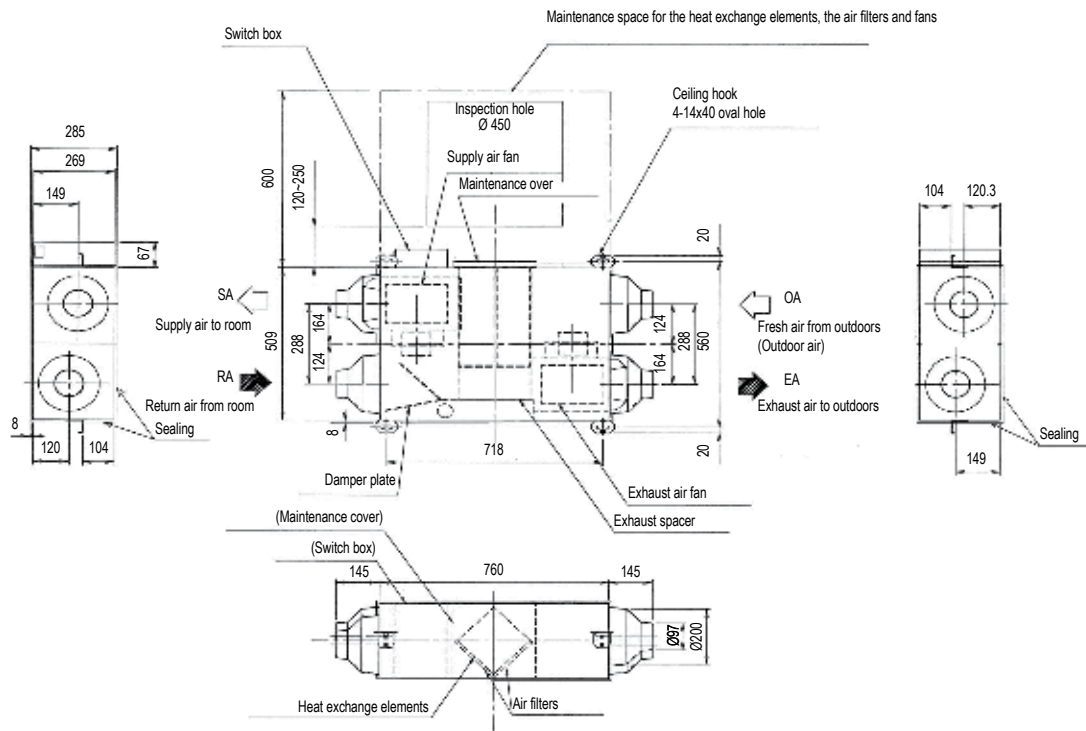

NOTE

- 1 Be sure to provide the inspection hole (450x450 mm) to inspect the air filters, the exchange elements and fans.

3TW27874-1

VAM250FC

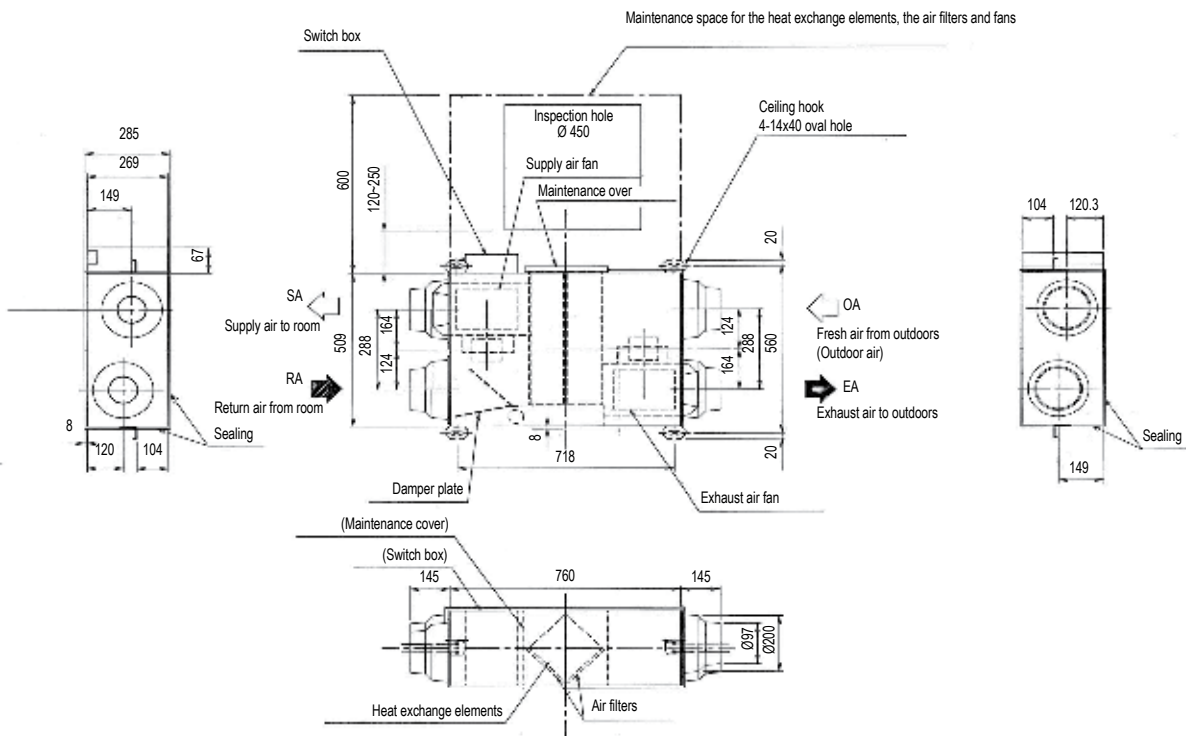

NOTE

- 1 Be sure to provide the inspection hole (450x450 mm) to inspect the air filters, the exchange elements and fans.

3TW27884-1



VAM350FC

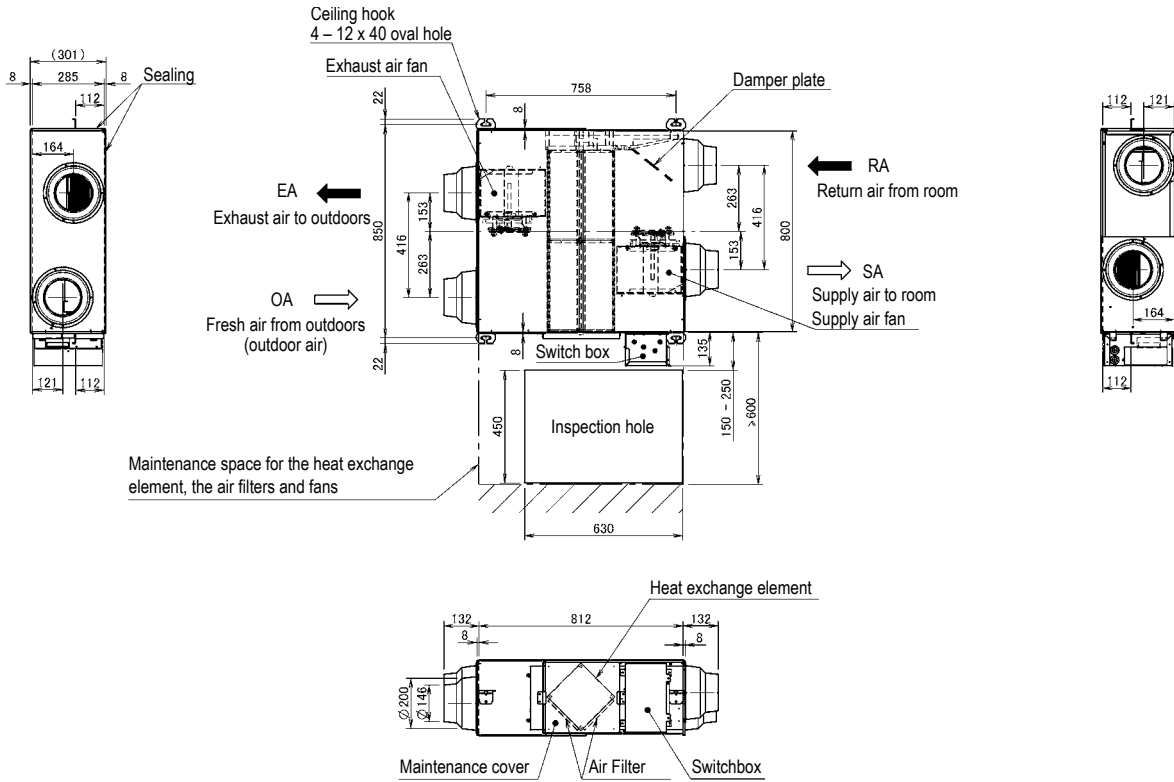

NOTES

1. Be sure to provide the inspection hole to inspect the air filters, the exchange elements and fans.

3D081162

VAM500FC

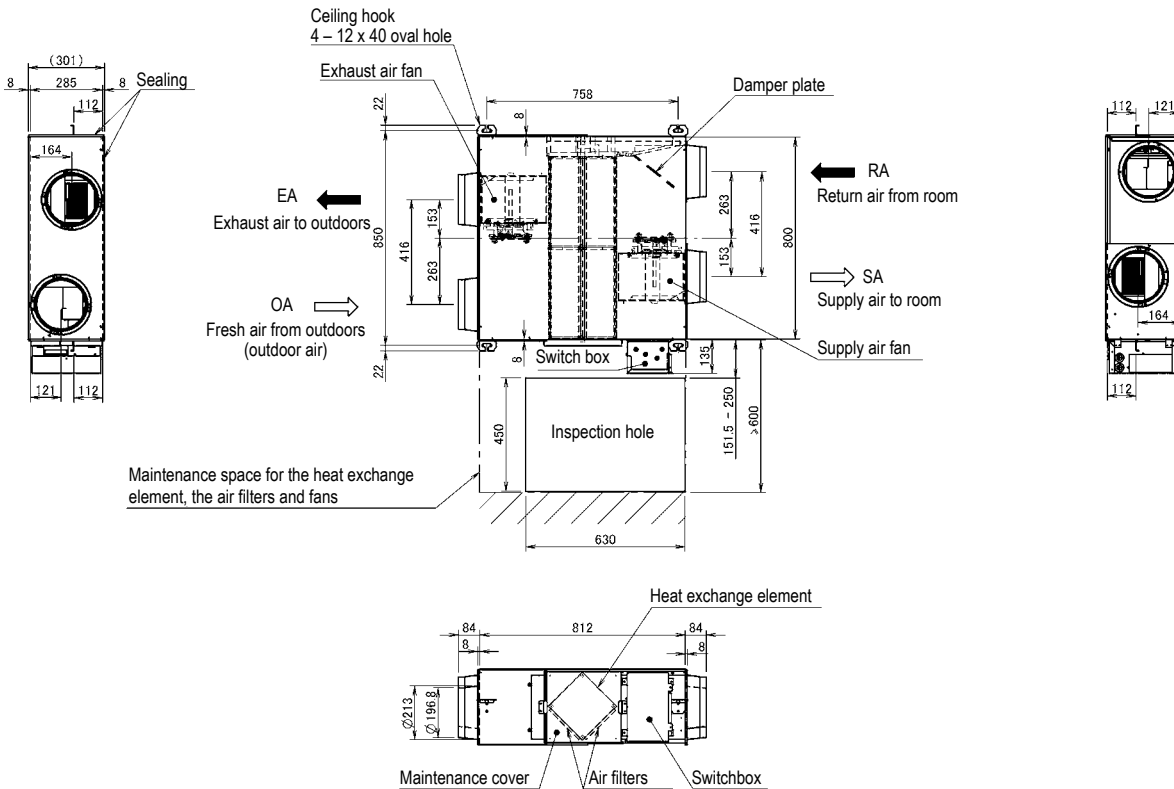

NOTES

1. Be sure to provide the inspection hole to inspect the air filters, the exchange elements and fans.

3D081163



VAM650FC

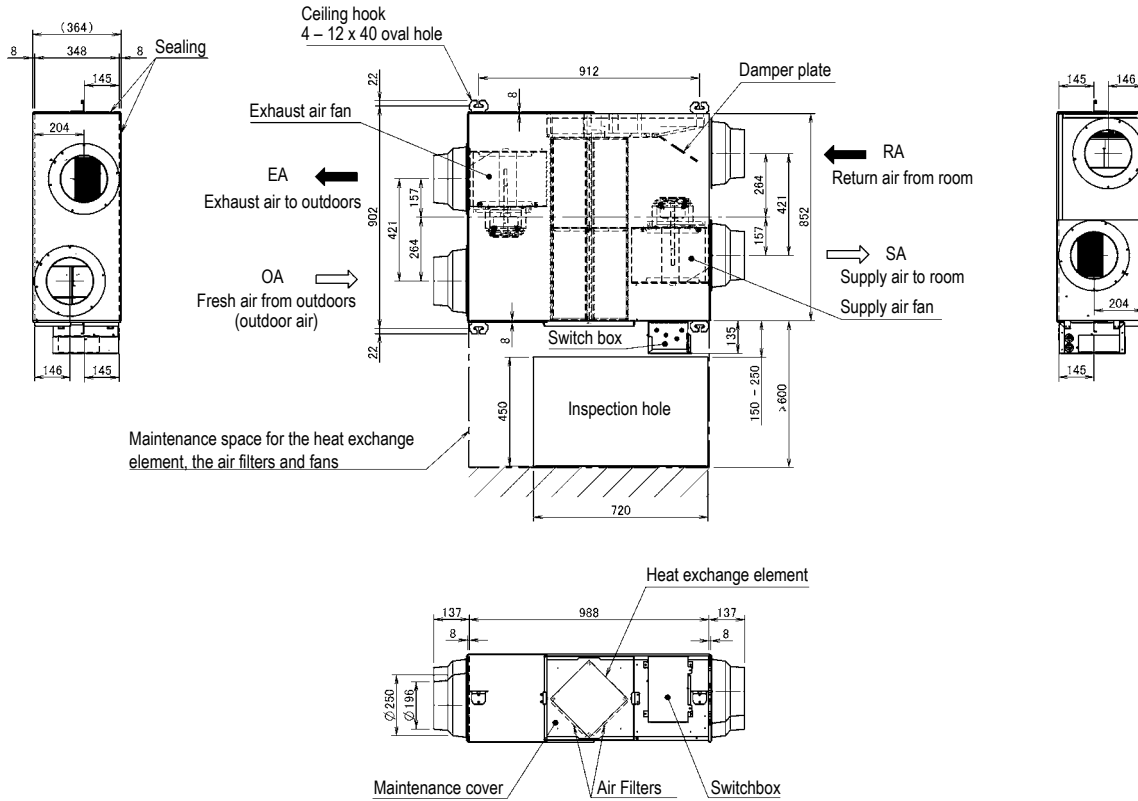

NOTES

1. Be sure to provide the inspection hole to inspect the air filters, the exchange elements and fans.

3D081164

VAM800FC

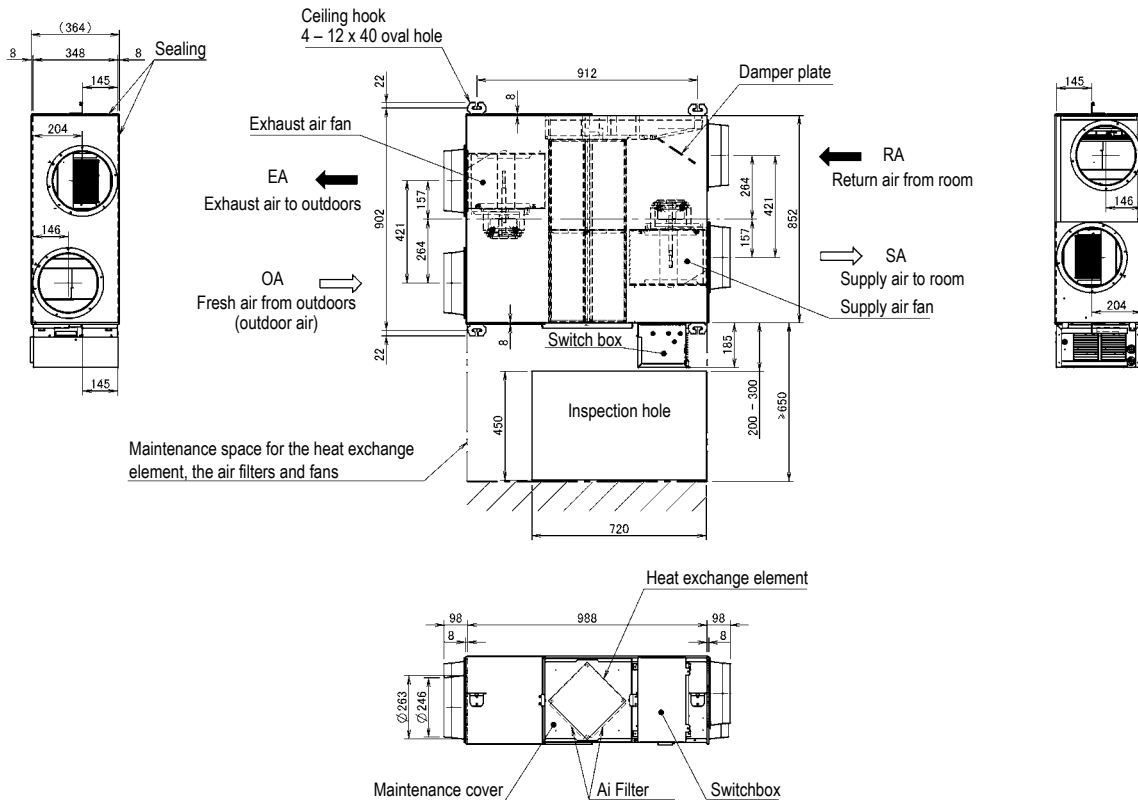

NOTES

1. Be sure to provide the inspection hole to inspect the air filters, the exchange elements and fans.

3D081165



VAM1000FC

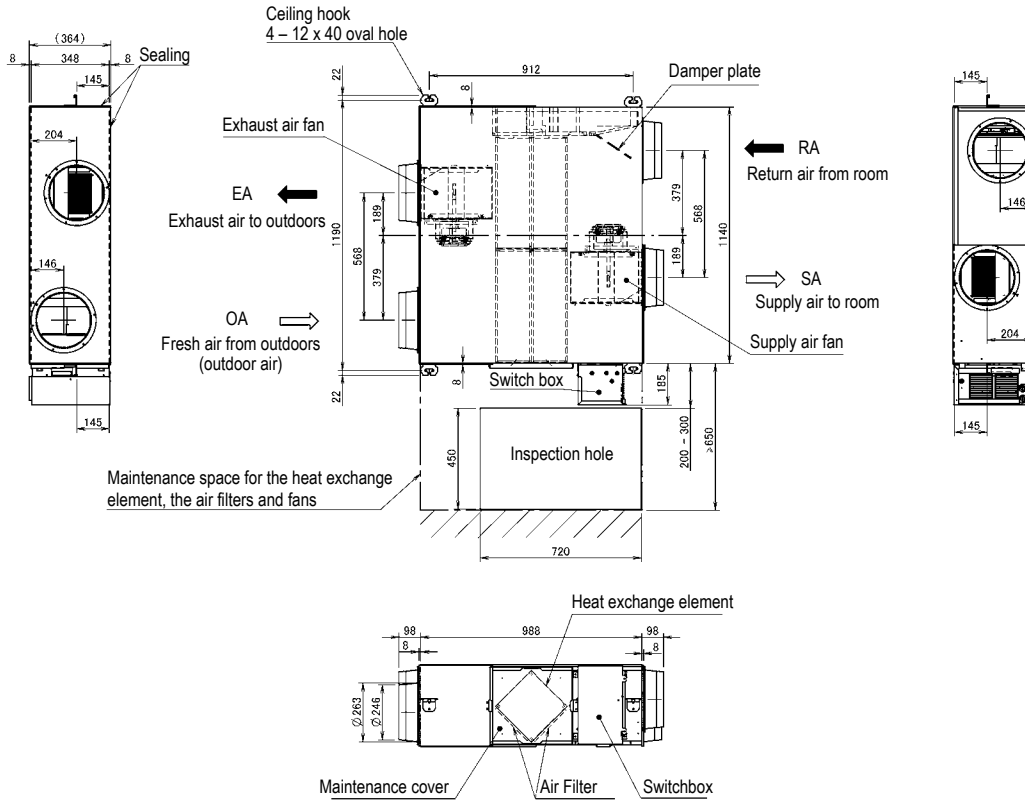

NOTES

1. Be sure to provide the inspection hole to inspect the air filters, the exchange elements and fans.

3D081166

VAM1500FC

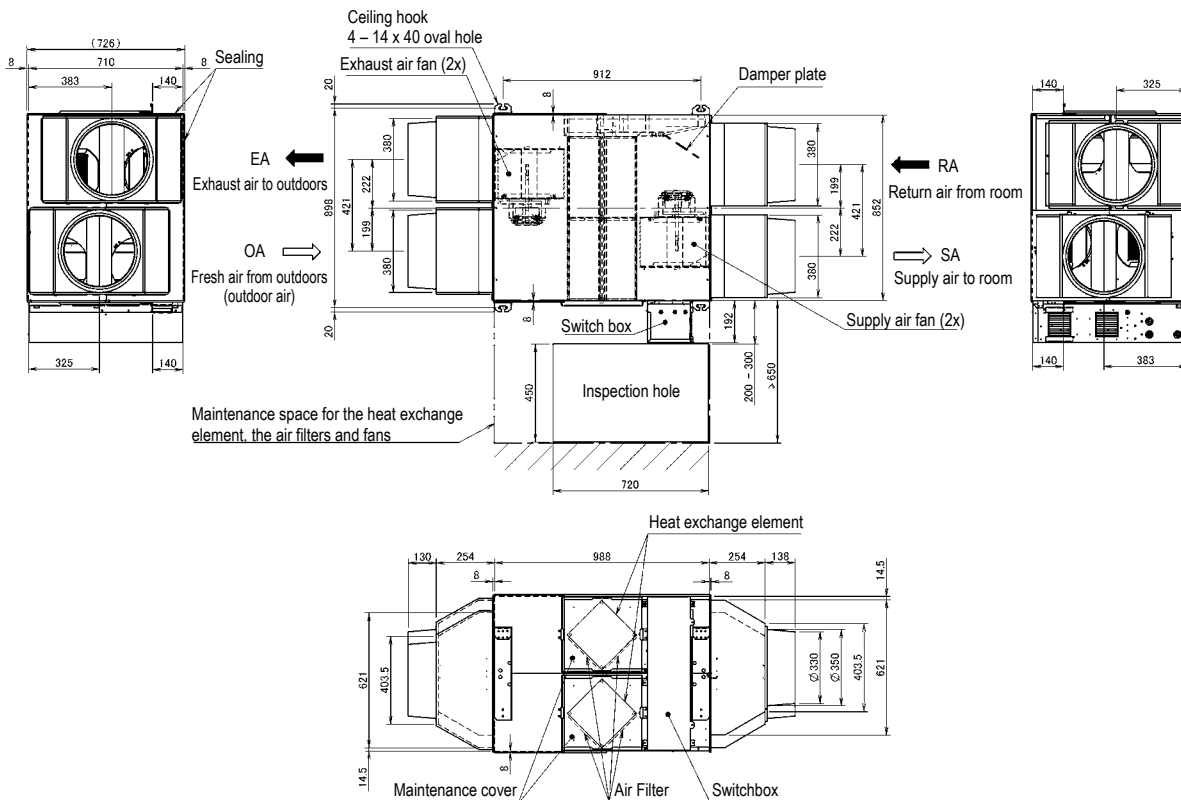

NOTES

1. Be sure to provide the inspection hole to inspect the air filters, the exchange elements and fans.

3D081167



VAM250FC

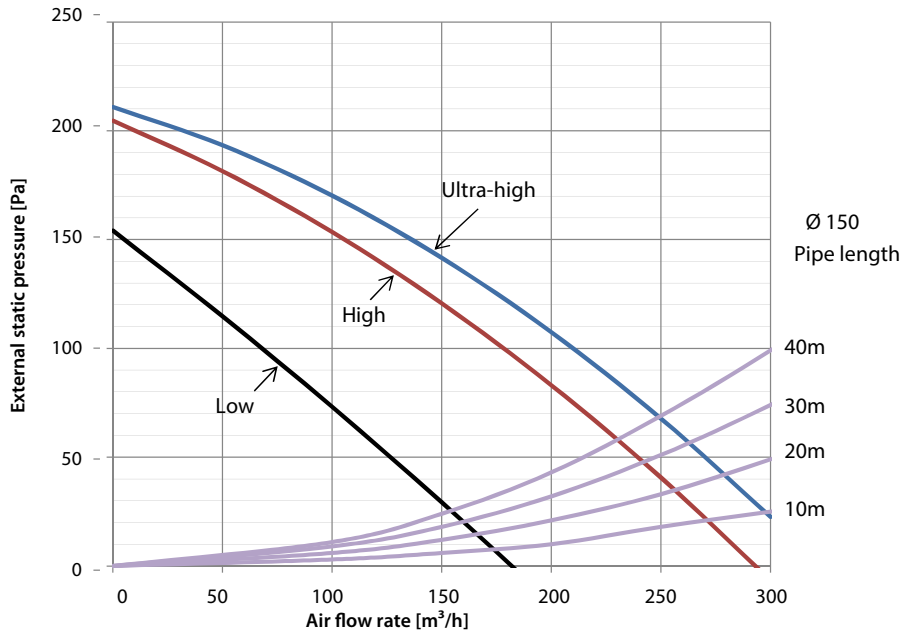

Notes

1. The fan speeds are valid for ~230-V, ~50-Hz power supply.

4D100380

VAM350FC

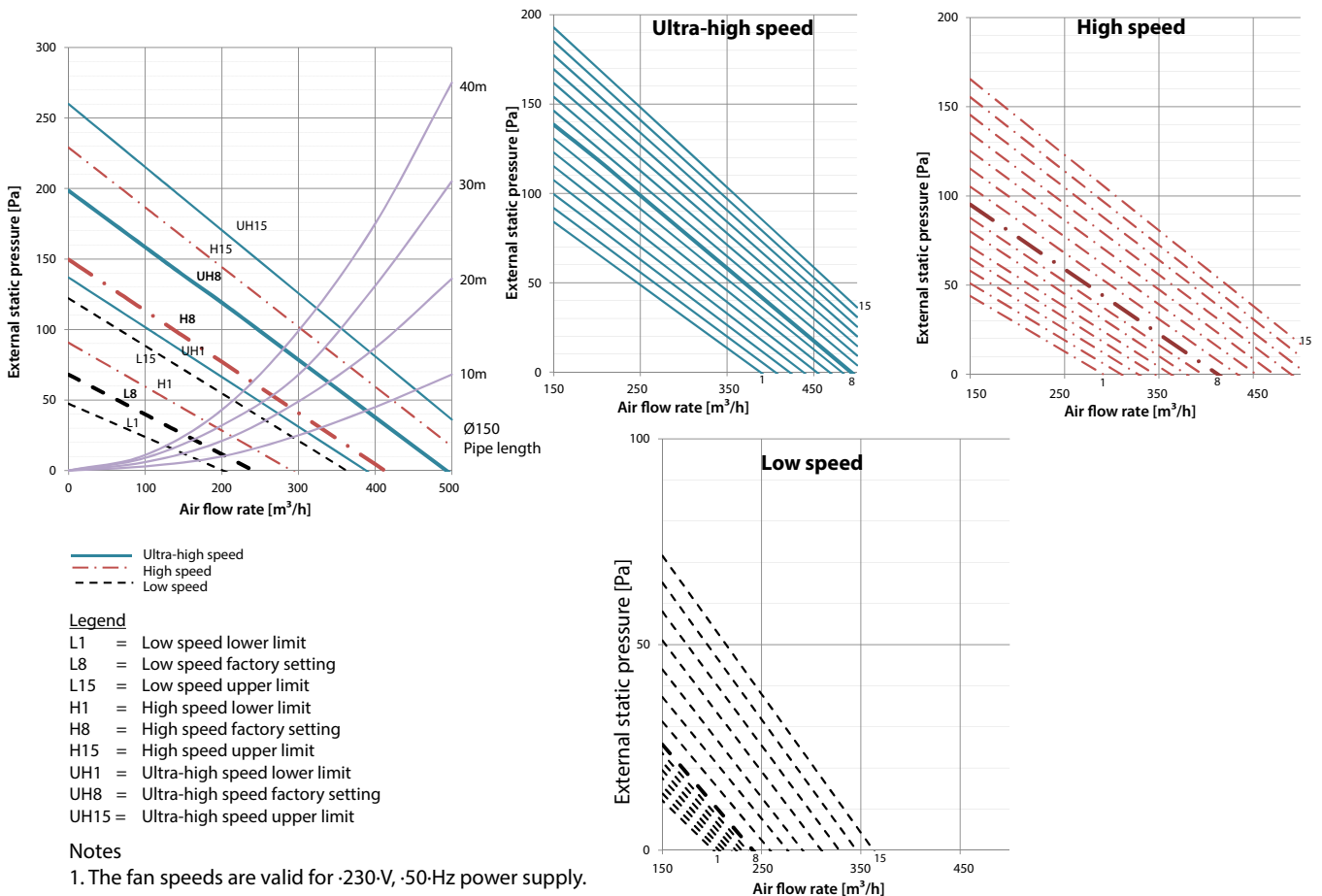



VAM500FC

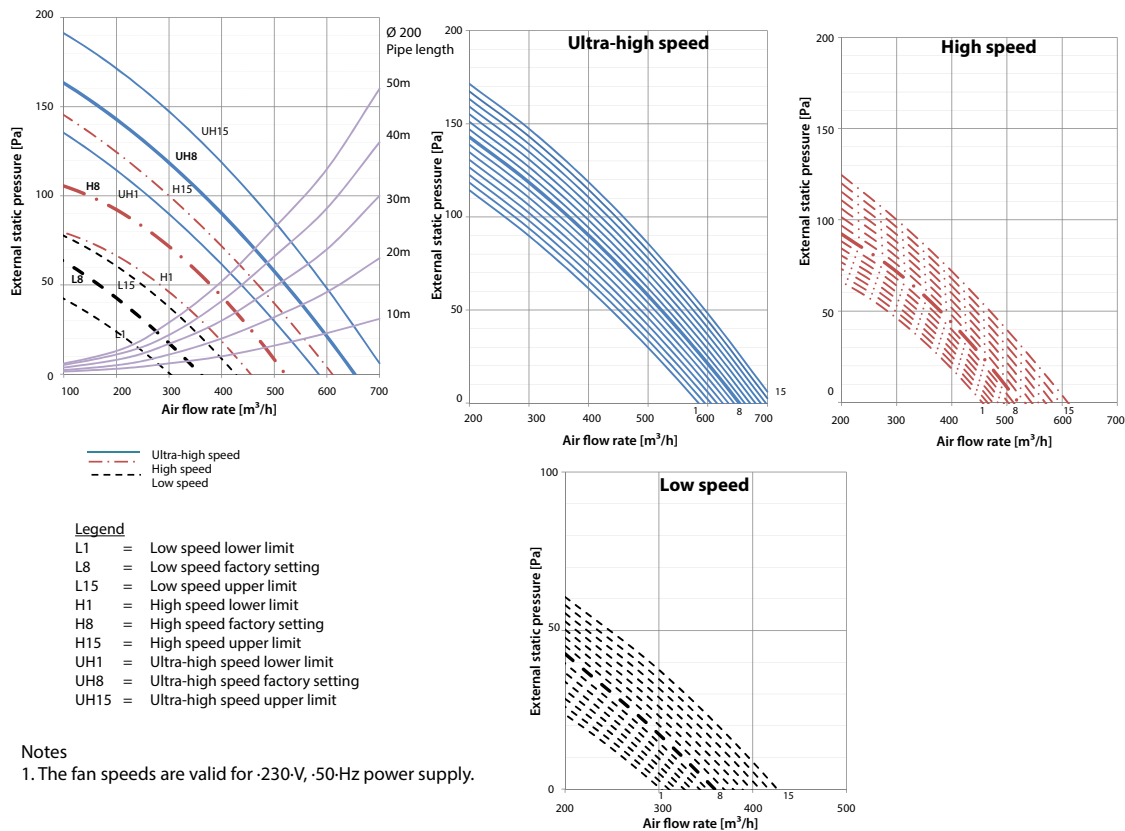

3D100382

VAM650FC

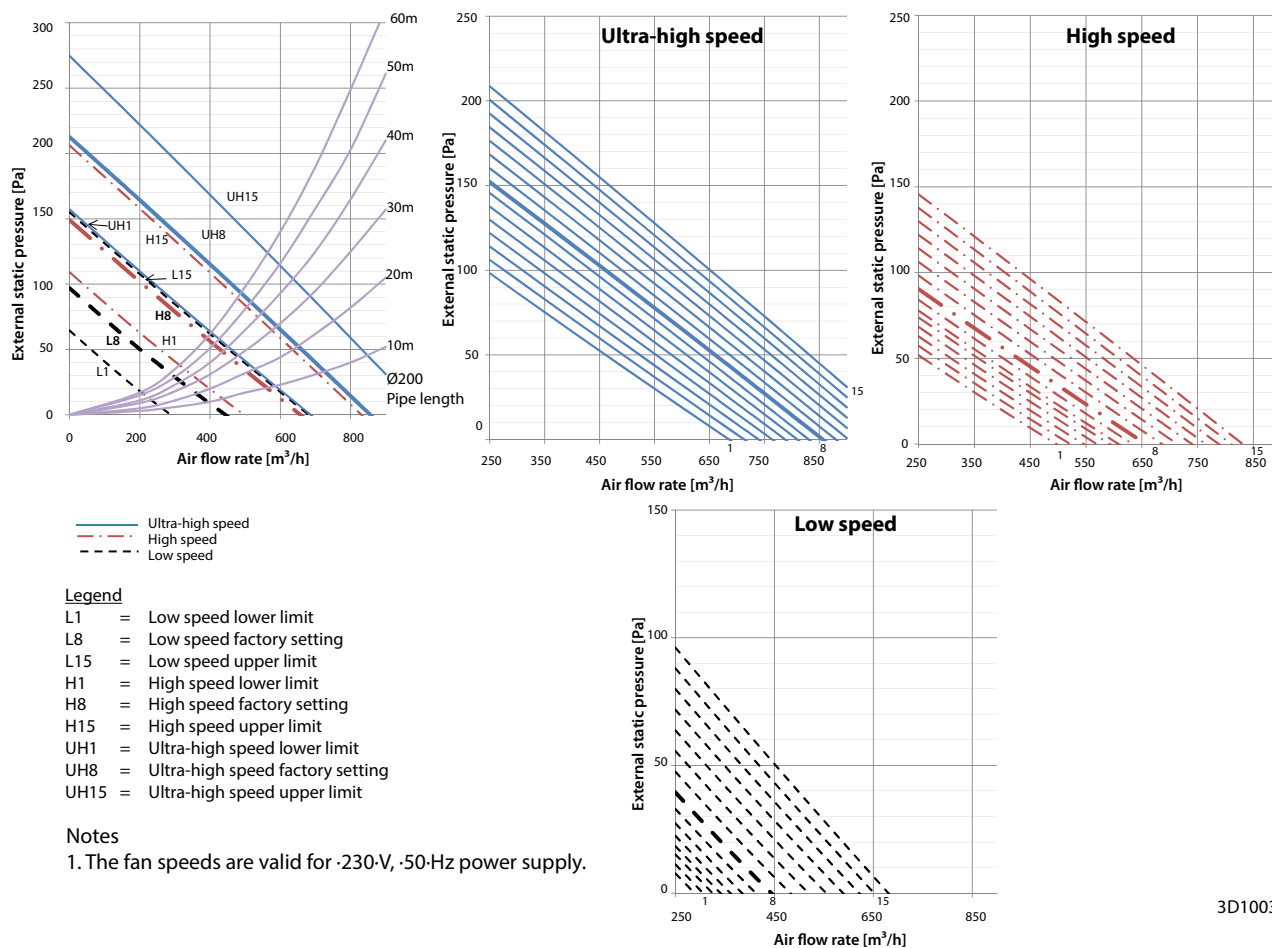

3D100383



VAM800FC

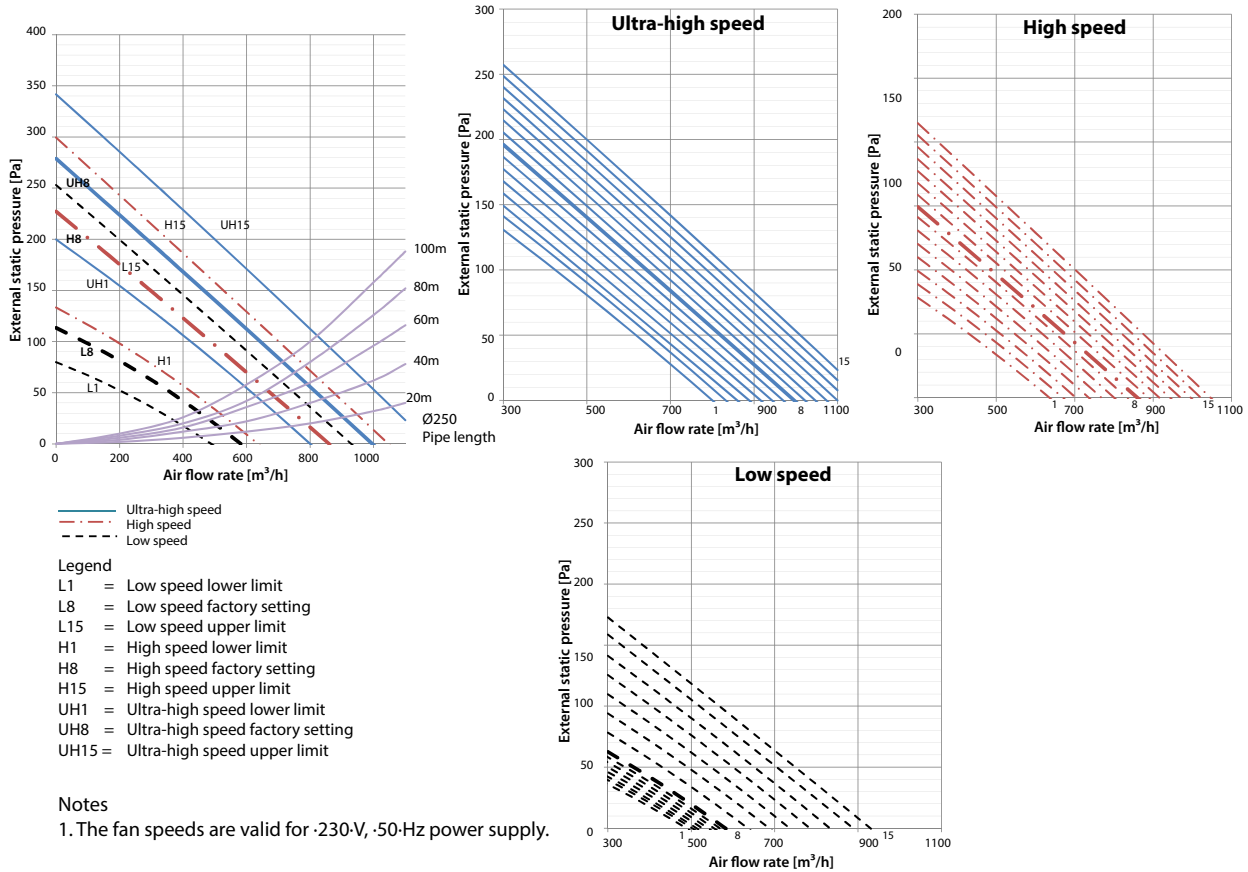

3D100384

VAM1000FC

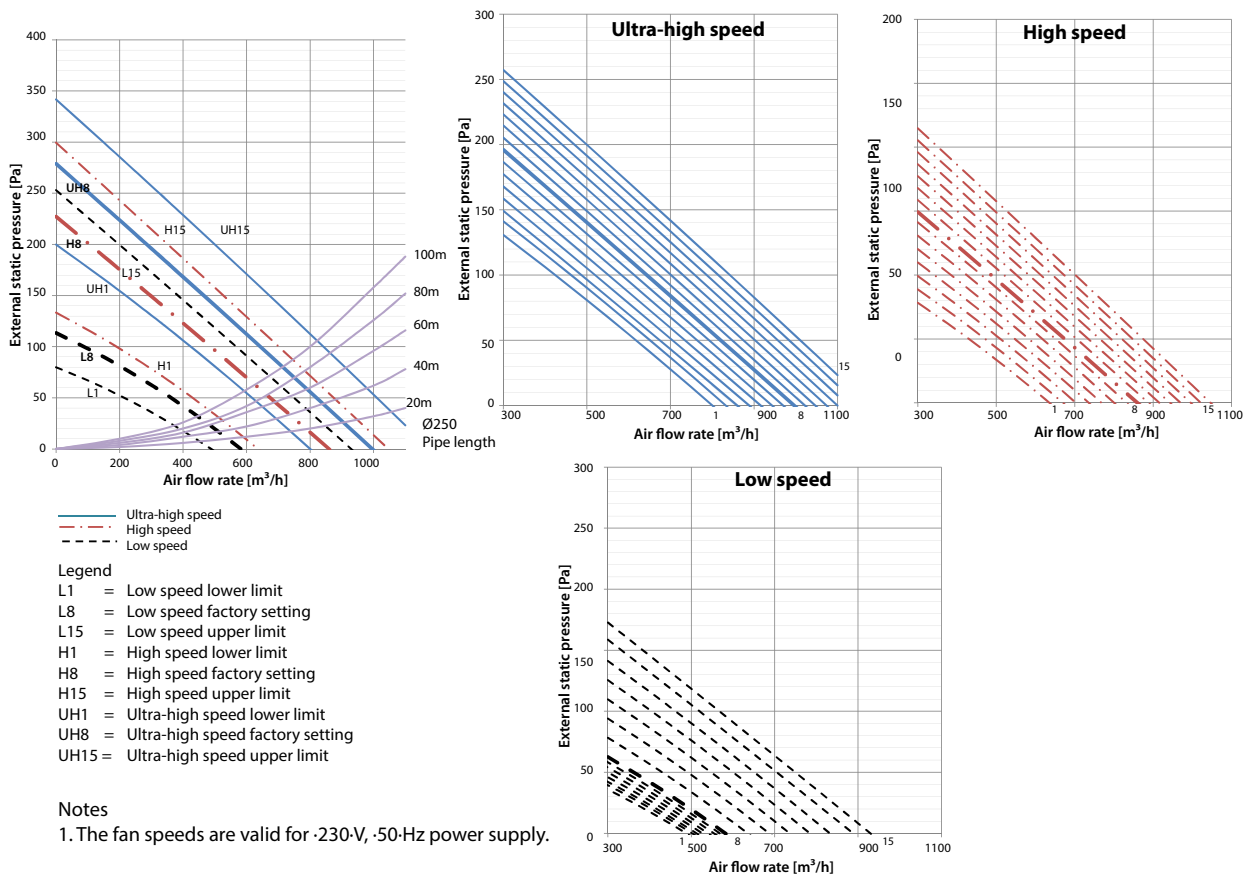

3D100384



VAM1500FC

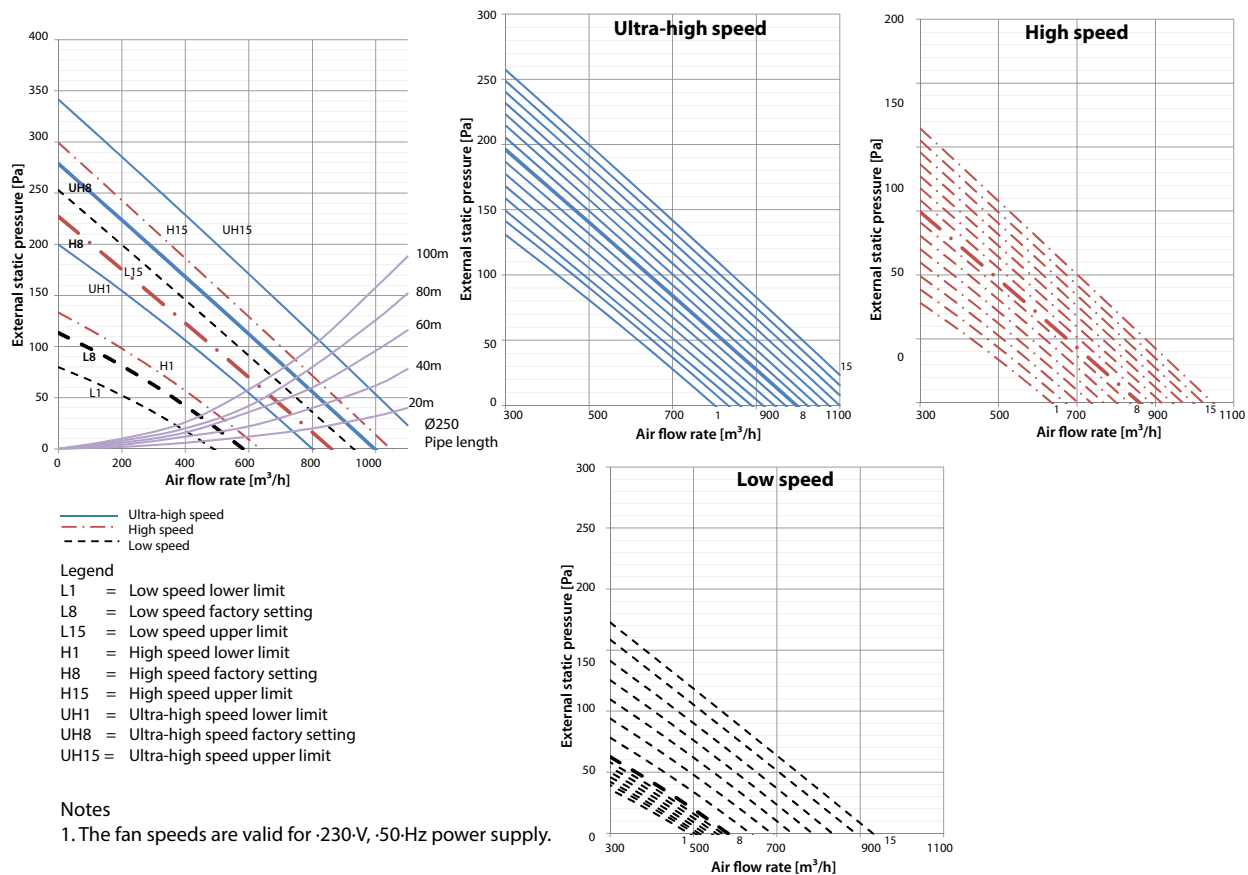

3D100384

VAM2000FC

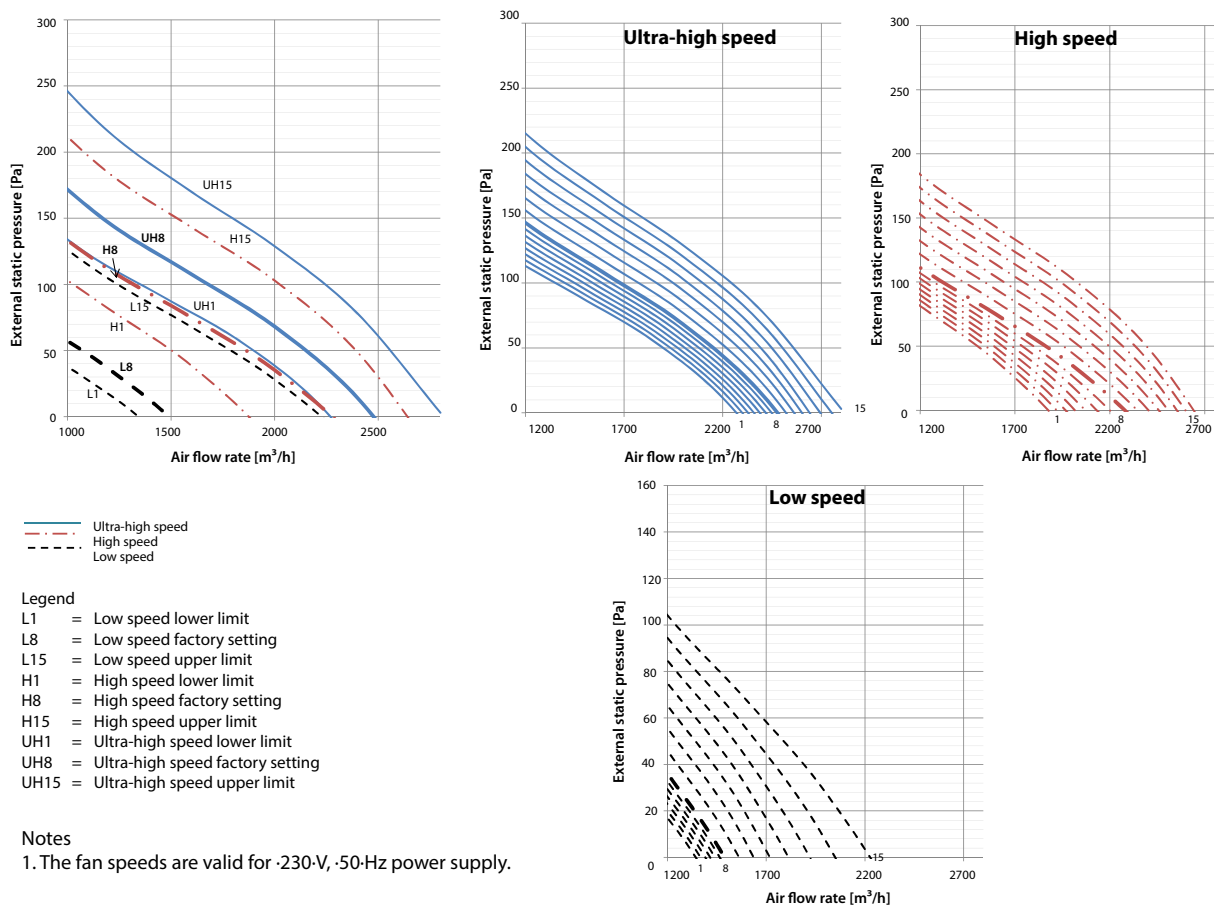



The future is in
your hands
Define the future of A/C

Introducing the new Sky Air A-series with ultra-efficient Bluevolution R32 technology, available in three models: the world-class Alpha, Advance and Active.

The new Sky Air with R32 delivers future-proofed, best-in-class climate control for your business and customers.

Design flexibility. More compact. Quieter. With an extended operating range in all climate conditions.

Help is at hand. Quicker and easier installation and usability, even for replacement systems.

Daikin at the heart of the system. Exceptionally low running costs. Even lower environmental impact. All thanks to Daikin's tried, tested and trusted technology.

Geared for comfort. Optimal remote control, geared to your customers' individual needs.

R32 is an industry revolution. Be part of it.

Get ahead of the competition. Talk to Daikin about Sky Air today.
www.daikin.eu/skyairbluevolution



SkyAir Alpha-series

SkyAir Advance-series

SkyAir Active-series

BLUEVOLUTION

Daikin Europe N.V. Naamloze Vennootschap Zandvoordestraat 300 · 8400 Oostende · Belgium · www.daikin.eu · BE 0412 120 336 · RPR Oostende (Responsible Editor)

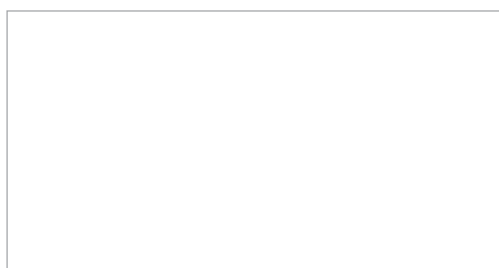

ECPEN18-100 07/17



Daikin Europe N.V. participates in the Eurovent Certified Performance programme for Liquid Chilling Packages and Hydronic Heat Pumps, Fan Coil Units and Variable Refrigerant Flow systems. Check ongoing validity of certificate: www.eurovent-certification.com

The present publication is drawn up by way of information only and does not constitute an offer binding upon Daikin Europe N.V. Daikin Europe N.V. has compiled the content of this publication to the best of its knowledge. No express or implied warranty is given for the completeness, accuracy, reliability or fitness for particular purpose of its content and the products and services presented therein. Specifications are subject to change without prior notice. Daikin Europe N.V. explicitly rejects any liability for any direct or indirect damage, in the broadest sense, arising from or related to the use and/or interpretation of this publication. All content is copyrighted by Daikin Europe N.V. The present publication supersedes ECPEN14-115. Printed on non-chlorinated paper. Prepared by Platzer Kommunikation, Germany.